

GRUPPO CARROZZERIA E CHASSIS
 BODY AND CHASSIS GROUP
 GROUPE CARROSSERIE ET CHASSIS
 KARROSSERIE UND GEHÄUSE

Mod. 1996

001

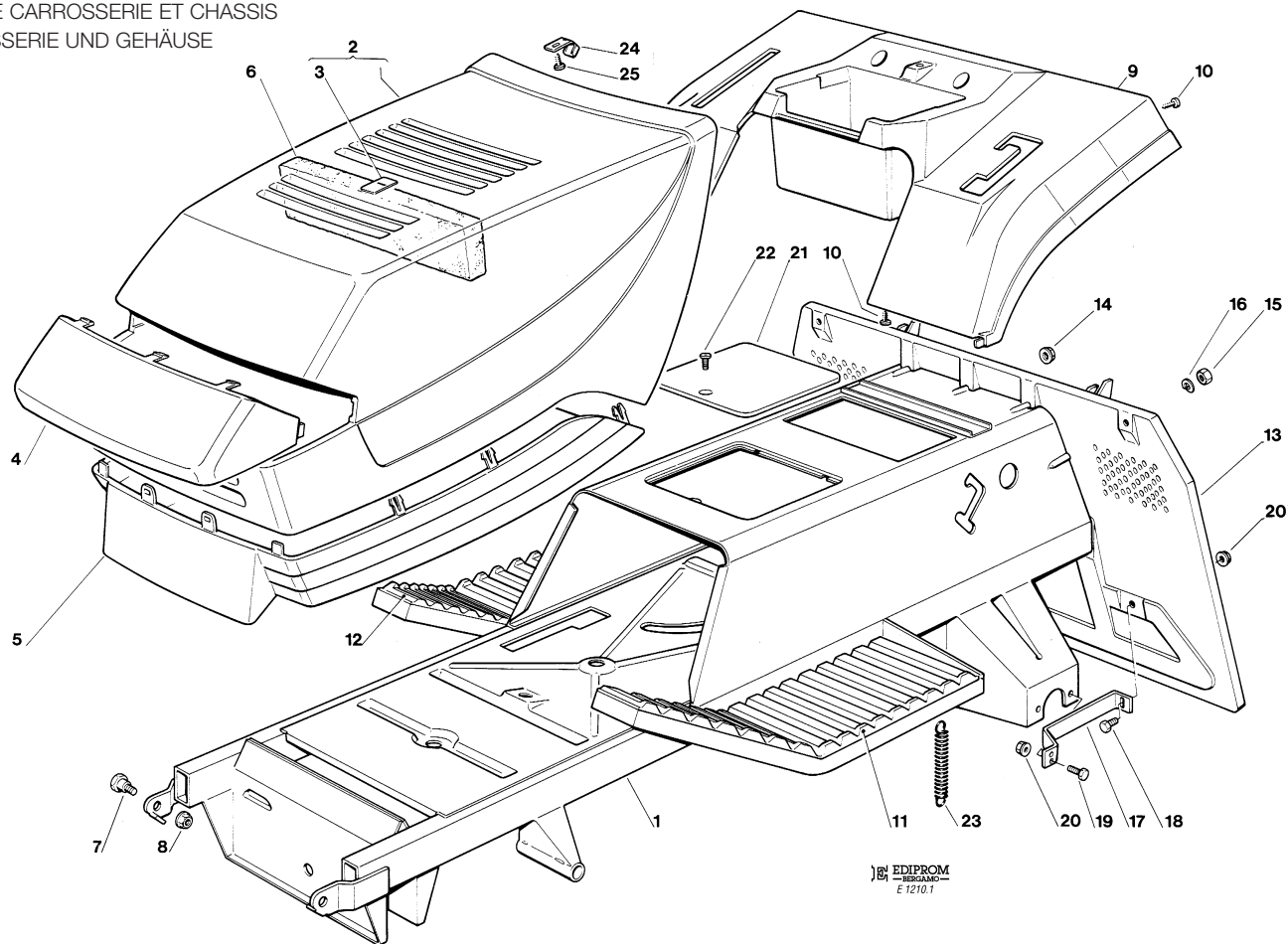

Pos. Nr.	Codice Kodex Code	Descrizione	Description	Description	Beschreibung	Q.tà Q.ty Q.té Menge
1	82800005/6	ASS. TELAIO	CHASSIS ASS.Y	ENSEMBLE CHASSIS	RAHMENSATZ	1
2	☛	COFANO SUPER. (TC)	UPPER ENGINE HOOD (TC)	CAPOT SUPERIEURE (TC)	OBERHAUBESATZ (TC)	1
	82076801/1	ROSSO	RED	ROUGE	ROT	
	82076804/0	VERDE	GREEN	VERT	GRÜN	
	82076805/0	GIALLO	YELLOW	JAUNE	GELB	
	82076807/0	BLU	BLUE	BLEU	BLAU	
	☛	COFANO SUPER. (TCP)	UPPER ENGINE HOOD (TCP)	CAPOT SUPERIEURE (TCP)	OBERHAUBESATZ (TCP)	1
	82076840/0	ROSSO	RED	ROUGE	ROT	
	82076842/0	VERDE	GREEN	VERT	GRÜN	
	82076844/0	GIALLO	YELLOW	JAUNE	GELB	
	82076846/0	BLU	BLUE	BLEU	BLAU	
3	☛	PIASTRINA (TC)	PLATE (TC)	PLAQUE (TC)	PLATTE (TC)	1
	25547016/1	ROSSA	RED	ROUGE	ROT	
	25547015/0	VERDE	GREEN	VERT	GRÜN	
	25547014/0	GIALLA	YELLOW	JAUNE	GELB	
	25547024/0	BLU	BLUE	BLEU	BLAU	
	☛	PIASTRINA (TCP)	PLATE (TCP)	PLAQUE (TCP)	PLATTE (TCP)	1
	25547025/0	ROSSA	RED	ROUGE	ROT	
	25547026/0	VERDE	GREEN	VERT	GRÜN	
	25547027/0	GIALLA	YELLOW	JAUNE	GELB	
	25547028/0	BLU	BLUE	BLEU	BLAU	
4	25410858/0	MASCHERINA (TC)	GRILL (TC)	PANNEAU (TC)	SCHUTZ (TC)	1
	25410860/0	MASCHERINA DX (TCP)	RIGHT GRILL (TCP)	PANNEAU DROITE (TCP)	RECHTE SCHUTZ (TCP)	1
	25410861/0	MASCHERINA SX (TCP)	LEFT GRILL (TCP)	PANNEAU GAUCHE (TCP)	LINKE SCHUTZ (TCP)	1
5	25076802/0	COFANO INFERIORE (TC)	LOWER ENGINE HOOD (TC)	CAPOT INFERIEURE (TC)	UNTERHAUBESATZ (TC)	1
	25076808/0	COFANO INFERIORE (TCP)	LOWER ENGINE HOOD (TCP)	CAPOT INFERIEURE (TCP)	UNTERHAUBESATZ (TCP)	1

Pos. Nr.	Codice Kodex Code	Descrizione	Description	Description	Beschreibung	Q.tà Q.ty Q.té Menge
6	25730000/0	SEPARATORE ASPIRAZ. (TC - 15,5 - 16 HP B&S)	INTAKE SEPARATOR (TC - 15,5 - 16 HP B&S)	SEPARATEUR ASPIRATIONS (TC - 15,5 - 16 HP B&S)	AUGENABSCHNEIDER (TC - 15,5 - 16 HP B&S)	1
	25730003/0	SEPARATORE ASPIRAZ. (TCP - 18 HP KOHLER)	INTAKE SEPARATOR (TCP - 18 HP KOHLER)	SEPARATEUR ASPIRATIONS (TCP - 18 HP KOHLER)	AUGENABSCHNEIDER (TCP - 18 HP KOHLER)	1
	25730002/0	SEPARATORE ASPIRAZ. (TCP - 15,5 - 16 HP B&S)	INTAKE SEPARATOR (TCP - 15,5 - 16 HP B&S)	SEPARATEUR ASPIRATIONS (TCP - 15,5 - 16 HP B&S)	AUGENABSCHNEIDER (TCP - 15,5 - 16 HP B&S)	1
7	25510015/1	PERNO	PIN	PIVOT	BOLZEN	2
	25510023/1	PERNO (18 HP KOHLER)	PIN (18 HP KOHLER)	PIVOT (18 HP KOHLER)	BOLZEN (18 HP KOHLER)	2
8	12293201/0	DADO	NUT	ECROU	MUTTER	2
	12436050/0	PIASTRINA (TCP - 18 HP KOHLER)	PLATE (TCP - 18 HP KOHLER)	PLAQUETTE (TCP - 18 HP KOHLER)	PLATTE (TCP - 18 HP KOHLER)	2
9	☛	COPERTURA RUOTE (TC)	WHEELS COVER (TC)	COUVRE-ROUES (TC)	RADENKAPPE (TC)	1
	25110157/1	ROSSA	RED	ROUGE	ROT	
	25110159/0	VERDE	GREEN	VERT	GRÜN	
	25110161/0	GIALLO	YELLOW	JAUNE	GELB	
	25110163/0	BLU	BLUE	BLEU	BLAU	
	☛	COPERTURA RUOTE (TCP)	WHEELS COVER (TCP)	COUVRE-ROUES (TCP)	RADENKAPPE (TCP)	1
	25110170/0	ROSSA	RED	ROUGE	ROT	
	25110171/0	VERDE	GREEN	VERT	GRÜN	
	25110172/0	GIALLO	YELLOW	JAUNE	GELB	
	25110173/0	BLU	BLUE	BLEU	BLAU	
10	12735402/0	VITE	SCREW	VIS	SCHRAUBE	4
11	25110260/1	COPRIPEDANA SX	LEFT FOOTBOARD COVER	COUVRE MARCHEPIED GAUCHE	LINKE FUSSBRETTDECKEL	1
12	25110261/1	COPRIPEDANA DX	RIGHT FOOTBOARD COVER	COUVRE MARCHEPIED DROITE	RECHTE FUSSBRETTDECKEL	1
13	82547001/2	ASS. PIASTRA POST.	REAR PLATE ASS.Y	ENS. PLAQUE POSTERIEURE	HINTERPLATTESATZ	1
14	12293201/0	DADO	NUT	ECROU	MUTTER	5
15	12295200/0	DADO	NUT	ECROU	MUTTER	2
16	12585100/0	GROWER	GROWER	GROWER	GROWER	2
17	25650021/0	RINFORZO PIASTRA POST.	REAR PLATE STIFFENING	RENFORCEMENT PLAQUE POST.	HINTERPLATTEVERSTA- ERKUNG	2
18	12792610/0	VITE	SCREW	VIS	SCHRAUBE	2
19	12793301/0	VITE	SCREW	VIS	SCHRAUBE	2
20	12293201/0	DADO	NUT	ECROU	MUTTER	4
21	82597120/0	PORTINA	HANDHOLE	GRILLE	GITTER	1
22	12728440/0	VITE	SCREW	VIS	MUTTER	1
23	25430218/0	MOLLA	SPRING	RESSORT	FEDER	2
24	25430217/0	MOLLA AGGANCIO (TCP)	COUPLING SPRING (TCP)	RESSORT ACCROCHA (TCP)	GEKUPPLUNGSFEDER (TCP)	2
25	12728099/0	VITE (TCP)	SCREW (TCP)	VIS (TCP)	SCHARUBE (TCP)	2

GRUPPO CRUSCOTTO E SEDILE
 DASHBOARD AND SEAT ASS.Y
 ENS. TABLEAU COMMANDES ET SIEGE
 KONSOLE UND SITZ

Mod. 1996

002

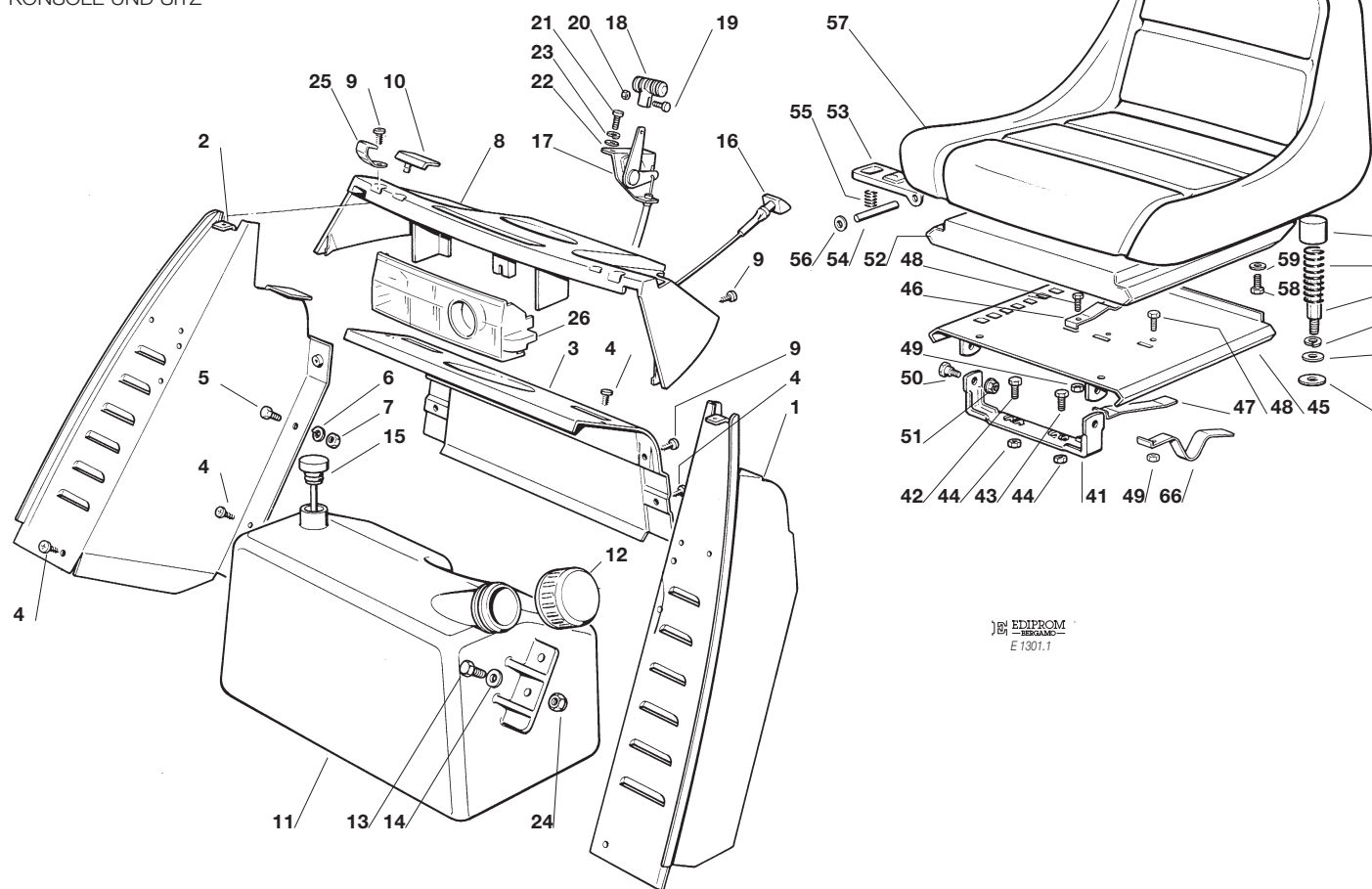

Pos. Nr.	Codice Kodex Code	Descrizione	Description	Description	Beschreibung	Q.tà Q.ty Q.té Menge
1	82785021/3	SUPP. CRUSCOTTO SX	LEFT DASHBOARD SUPP.	SUPPORT TABLEAU GAUCHE	LINKER KONSOLEHALTER	1
2	82785022/2	SUPP. CRUSCOTTO DX	RIGHT DASHBOARD SUPP.	SUPPORT TABLEAU DROITE	RECHTER KONSOLEHALTER	1
3	82785023/0	SUPP. CRUSCOTTO CENTR.	CENTRAL DASHBOARD SUPP.	SUPPORT TABLEAU CENTRAL	ZENTRALER KONSOLE HALTER	1
4	12728440/0	VITE	SCREW	VIS	SCHRAUBE	8
5	12790780/0	VITE	SCREW	VIS	SCHRAUBE	2
6	12582100/0	GROWER	GROWER	GROWER	GROWER	2
7	12292100/0	DADO	NUT	ECROU	MUTTER	2
8	25120144/1	CRUSCOTTO COMANDI (TC)	DASHBOARD (TC)	TABLEAU COMMANDES (TC)	KONSOLE (TC)	1
	25120145/0	CRUSCOTTO COMANDI (TCP)	DASHBOARD (TCP)	TABLEAU COMMANDES (TCP)	KONSOLE (TCP)	1
9	12728440/0	VITE (TC)	SCREW (TC)	VIS (TC)	SCHRAUBE (TC)	2
10	25260000/0	GOMMINO	GROMMET	PROTECTION	SCHUTZ	2
11	25735110/0	SERBATOIO (12,5 - 15,5 HP B&S 14 - 18 HP KOHLER)	TANK (12,5 - 15,5 HP B&S 14 - 18 HP KOHLER)	RESERVOIR (12,5 - 15,5 HP B&S 14 - 18 HP KOHLER)	TANK (12,5 - 15,5 HP B&S 14 - 18 HP KOHLER)	1
	25735111/0	SERBATOIO (16 HP B&S)	TANK (16 HP B&S)	RESERVOIR (16 HP B&S)	TANK (16 HP B&S)	1
12	25795000/0	TAPPO	CAP	BOUCHON	TANKVERSCHLUSS	1
13	12788910/0	VITE	SCREW	VIS	SCHRAUBE	2
14	12523020/0	RONDELLA	WASHER	RONDELLE	SCHEIBE	2
15	25290000/0	INDICATORE LIVELLO (16 HP B&S)	FUEL LEVEL INDICATOR (16 HP B&S)	INDICATEUR NIVEAU (16 HP B&S)	KRAFTSTOFFMESSER (16 HP B&S)	1
16	25090000/0	COMANDO STARTER (16 HP B&S)	STARTER DRIVE (16 HP B&S)	COMMANDE STARTER (16 HP B&S)	STARTER BETAETIGUNG (16 HP B&S)	1
	25090001/0	COMANDO STARTER (18 HP KOHLER)	STARTER DRIVE (18 HP KOHLER)	COMMANDE STARTER (18 HP KOHLER)	STARTER BETAETIGUNG (18 HP KOHLER)	1

Pos. Nr.	Codice Kodex Code	Descrizione	Description	Description	Beschreibung	Q.tà Q.ty Q.té Menge
17	82000200/1	ASS. ACCELERATORE (12,5 - 15,5 HP B&S)	ACCELERATOR ASS.Y (12,5 - 15,5 HP B&S)	ENSEMBLE ACCELERATEUR (12,5 - 15,5 HP B&S)	GAS ZUG (12,5 - 15,5 HP B&S)	1
	82000201/1	ASS. ACCELERATORE (16 HP B&S)	ACCELERATOR ASS.Y (16 HP B&S)	ENSEMBLE ACCELERATEUR (16 HP B&S)	GAS ZUG (16 HP B&S)	
	82000203/0	ASS. ACCELERATORE (14 HP KOHLER)	ACCELERATOR ASS.Y (14 HP KOHLER)	ENSEMBLE ACCELERATEUR (14 HP KOHLER)	GAS ZUG (14 HP KOHLER)	1
	82000204/0	ASS. ACCELERATORE (18 HP KOHLER)	ACCELERATOR ASS.Y (18 HP KOHLER)	ENSEMBLE ACCELERATEUR (18 HP KOHLER)	GAS ZUG (18 HP KOHLER)	1
18	25394501/0	MANOPOLA	HANDLE	POIGNE	GRIFF	1
19	12726388/0	VITE	SCREW	VIS	SCHRAUBE	1
20	12290800/0	DADO	NUT	ECROU	MUTTER	1
21	12788512/0	VITE	SCREW	VIS	SCHRAUBE	2
22	12521310/0	RONDELLA	WASHER	RONDELLE	SCHEIBE	2
23	12581200/0	GROWER	GROWER	GROWER	GROWER	2
24	12154330/0	DADO	NUT	ECROU	MUTTER	2
25	25430215/0	MOLLA AGGANCIO (TC)	COUPLING SPRING (TC)	RESSORT ACCROCHAGE (TC)	KUPPLUNGSFEDER	2
26	25600010/0	PROTEZIONE SCHEDA	CARD PROTECTION	PROTECTION DE CARTE	KARTESCHUTZ	1
41	82774207/0	STAFFA SUPP. SEDILE	SEAT CLAMP SUPPORT	ETRIER SUPPORT SIEGE	BRIDE F. SITZHALTER	1
42	12793500/0	VITE	SCREW	VIS	SCHRAUBE	1
43	12792610/0	VITE	SCREW	VIS	SCHRAUBE	1
44	12293901/0	DADO	NUT	ECROU	MUTTER	2
45	82785089/0	ASS. SUPP. SEDILE FISSO	FIXED SEAT SUPP.	SUPPORT SIEGE FIXE	FEST SITZHALTER	1
46	25430203/0	MOLLA ARRESTO	SPRING	RESSORT D'ARRET	RASTFEDER	1
47	25430224/0	MOLLA COMANDO	SPRING	RESSORT DE COMMANDE	FEDER	1
48	12789000/0	VITE	SCREW	VIS	SCHRAUBE	3
49	12154330/0	DADO	NUT	ECROU	MUTTER	3
50	22524970/1	PERNO	PIN	PIVOT	BOLZEN	2
51	12293201/0	DADO	NUT	ECROU	MUTTER	2
52	82785087/0	SUPPORTO SEDILE	SEAT SUPPORT	SUPPORT SIEGE	SITZHALTER	1
53	25318109/0	LEVA ARRESTO	STOP LEVER	LEVIER D'ARRET	ABSTELLHEBEL	1
54	25510000/0	PERNO	PIN	PIVOT	BOLZEN	1
55	25430202/0	MOLLA	SPRING	RESSORT	FEDER	1
56	12604897/0	RONDELLA	WASHER	RONDELLE	SCHEIBE	2
57	25722450/0	SEDILE (TC)	SEAT (TC)	SIEGE (TC)	SITZ (TC)	1
	25722451/0	SEDILE (TCP)	SEAT (TCP)	SIEGE (TCP)	SITZ (TCP)	1
58	12793101/0	VITE	SCREW	VIS	SCHRAUBE	4
59	12583500/0	GROWER	GROWER	GROWER	GROWER	4
60	25430205/0	MOLLA	SPRING	RESSORT	FEDER	2
61	25510016/0	PERNO	PIN	PIVOT	BOLZEN	2
62	12521350/0	RONDELLA	WASHER	RONDELLE	SCHEIBE	2
63	12583500/0	GROWER	GROWER	GROWER	GROWER	2
64	12523070/0	RONDELLA	WASHER	RONDELLE	SCHEIBE	2
65	25122000/0	CUFFIA PROTEZ.	HOOD	PROTECTEUR	SCHUTZKASTEN	2
66	25430223/0	MOLLA	SPRING	RESSORT	FERDER	1

GRUPPO STERZO
 STEERING GROUP
 GROUPE BARRE DE DIRECTION
 LENKGETRIEBE

Mod. 1996

003

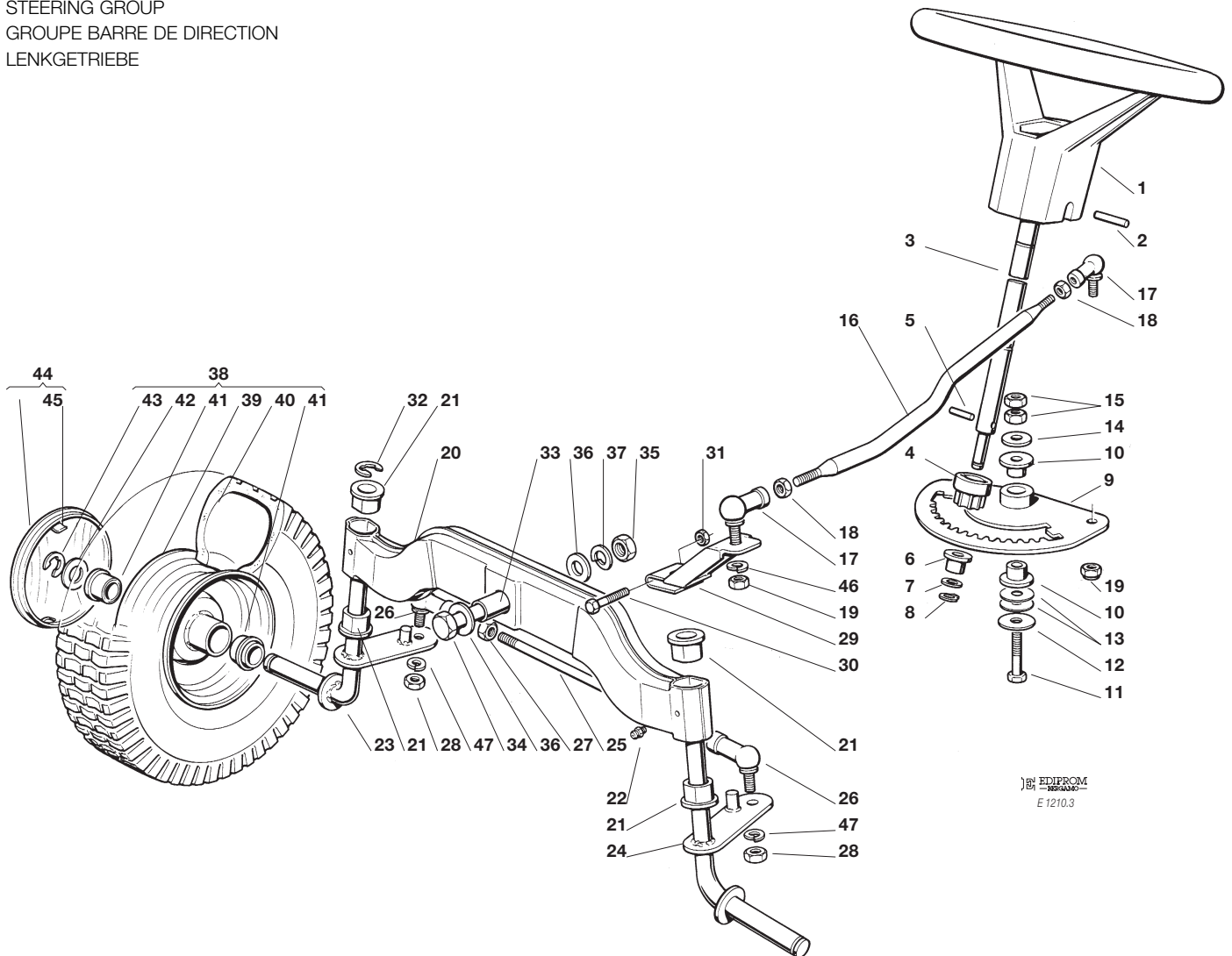

Pos. Nr.	Codice Kodex Code	Descrizione	Description	Description	Beschreibung	Q.tà Q.ty Q.té Menge
1	25961200/0	VOLANTE	STEERING WHEEL	VOLANT	LENKRAD	1
2	12620299/0	SPINA	PIN	GOUPILLE	STIFT	1
3	25520000/0	PIANTONE	STEERING COLUMN	TUBE DE DIRECTION	LENKUNGSÆULE	1
4	25570000/0	PIGNONE	PINION	PIGNON	RITZEL	1
5	12622650/0	SPINA	PIN	GOUPILLE	STIFT	1
6	25034001/0	BRONZINA	BRASS	COUSSINET	BÜCHSE	1
7	12521370/0	RONDELLA	WASHER	RONDELLE	SCHEIBE	1
8	12436030/0	PIASTRINA	PLATE	PLAQUETTE	PLATTECHEN	1
9	82735504/0	ASS. SETTORE STERZO	STEERING SHAFT ASS.Y	ENSEMBLE ARBRE DIRECTION	LENKUNGSWELLE	1
10	25160001/0	BRONZINA	BRASS	COUSSINET	BÜCHSE	2
11	12692420/0	VITE	SCREW	VIS	SCHRAUBE	1
12	12523090/0	RONDELLA	WASHER	RONDELLE	SCHEIBE	1
13	22672150/0	RONDELLA	WASHER	RONDELLE	SCHEIBE	2
14	25670002/0	RONDELLA	WASHER	RONDELLE	SCHEIBE	1
15	12295200/0	DADO	NUT	ECROU	MUTTER	2
16	25033003/1	ASS. ASTA COMANDO STERZO	STEERING ROD ASS.Y	ENS. LEVIER BARRE DE DIRECTION	LENKUNGSSTAB	1
17	22746600/0	SNODO M10	JOINT M10	JOINT M10	GELENK M10	2
18	12295200/0	DADO	NUT	ECROU	MUTTER	2
19	12295200/0	DADO	NUT	ECROU	MUTTER	2

Pos. Nr.	Codice Kodex Code	Descrizione	Description	Description	Beschreibung	Q.tà Q.ty Q.té Menge
20	82034001/1	BILANCIERE COMPLETO DI BRONZINA ED INGRASSATORE	EQUALIZER WITH BUSH AND LUBRICATOR	BALANCIER AVEC COUSSINET ET GRAISSEUR	KIPPHEBEL MIT BRONZE- LAGER UND FETTBUCHSE	1
21	25034002/0	BRONZINA	BRASS	COUSSINET	BÜCHSE	4
22	12379511/0	INGRASSATORE	GREASE DISPENSER	GRAISSEUR	FETTBUCHSE	2
23	82230349/0	ASS. FUSELLO DX	R. STUB AXLE ASS.Y	ENSEMBLE FUSEAU DROITE	RECHTER ACHSSCHENKEL	1
24	82230348/0	ASS. FUSELLO SX	L. STUB AXLE ASS.Y	ENSEMBLE FUSEAU GAUCHE	LINKER ACHSSCHENKEL	1
25	25840001/0	TIRANTE	TIE ROD	TIRANT	KUPPLUNG	1
26	22746600/0	SNODO M10	JOINT M10	JOINT M10	GELENK M10	2
27	12295200/0	DADO	NUT	ECROU	MUTTER	2
28	12295200/0	DADO	NUT	ECROU	MUTTER	2
29	82318101/0	ASS. LEVA COMANDO	LEVER ASS.Y	ENSEMBLE LEVIER	HEBEL	1
30	12691700/0	VITE	SCREW	VIS	SCHRAUBE	1
31	12155000/0	DADO	NUT	ECROU	MUTTER	1
32	12001000/0	ANELLO ELASTICO	SNAP RING	ANNEAU RESSORT	SPRENGRING	1
33	25160005/0	DISTANZIALE	SPACER	ENTRETOISE	ENTFERNUNGSSTUECK	1
34	12694100/0	VITE	SCREW	VIS	SCHRAUBE	1
35	12295800/0	DADO	NUT	ECROU	MUTTER	1
36	12521390/0	RONDELLA	WASHER	RONDELLE	SCHEIBE	2
37	12587900/0	GROWER	GROWER	GROWER	GROWER	1
38	82680002/0	RUOTA COMPLETA CON CUSCINETTI (TURF-SAVER)	WHEEL ASS.Y WITH BEARINGS (TURF-SAVER)	ENSEMBLE ROUE AVEC ROULEM. (TURF-SAVER)	VORDERRAD MIT KUGEL LAGER (TURF-SAVER)	2
39	82000590/0	ASS. CERCHIO RUOTA ANT.	FRONT RIMM ASS.Y	BANDAGE ROUE ANT.	VORDERRAD FELGER	2
40	25590000/0	PNEUMATICO (TURF-SAVER)	SHOE (TURF-SAVER)	PNEU (TURF-SAVER)	REIFEN (TURF-SAVER)	2
41	25122200/1	CUSCINETTO	BEARING	ROULEMENT	LAGER	4
42	25670005/1	RONDELLA SPESSORE 2,5 MM	WASHER THICKNEE 2.5 MM	RONDELLE EPAISSEUR 2,5 MM	SCHEIBE DICKE 2,5 MM	2
43	12001000/0	ANELLO ELASTICO	SNAP RING	ANNEAU RESSORT	SPRENGRING	2
44	82110250/1	ASS. COPRIDISCO RUOTA ANTERIORE (TC)	FRONT WHEEL COVERENS. ASS.Y (TC)	COUVRE DISQUE ROUE ANTERIEURE (TC)	VORRDERRAD DECKEL (TC)	2
	82110252/0	ASS. COPRIDISCO RUOTA ANTERIORE (TCP)	FRONT WHEEL COVERENS. ASS.Y (TCP)	COUVRE DISQUE ROUE ANTERIEURE (TCP)	VORRDERRAD DECKEL (TCP)	2
45	25430209/0	MOLLA AGGANCIO	SPRING	RESSORT	FEDER	8
46	12585100/0	GROWER	GROWER	GROWER	GROWER	2
47	12585100/0	GROWER	GROWER	GROWER	GROWER	2

GRUPPO COMANDO CAMBIO E FRENO
 GEARBOX AND BRAKE ASS.Y
 GROUPE BOITE DE VITESSE ET FREIN
 WECHSEL UND BREMSE SATZ

Mod. 1996 **004**

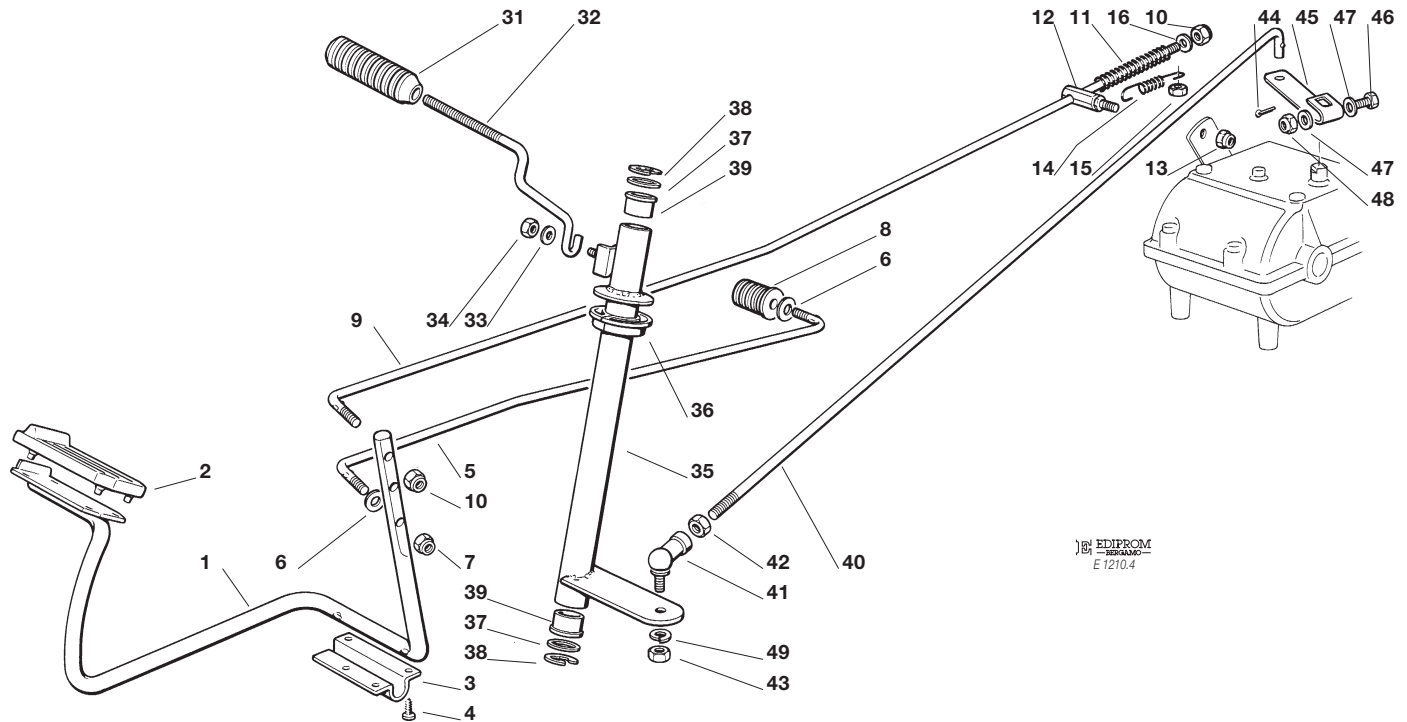

Pos. Nr.	Codice Kodex Code	Descrizione	Description	Description	Beschreibung	Q.tà Q.ty Q.té Menge
1	82500000/1	ASS. PEDALE FRENO	BRAKE PEDAL ASS.Y	ENSEMBLE PEDALE DE FREIN	BREMSPEDAL	1
2	25110262/1	COPRISTAFFA	CLAMP COVER	COUVRE ETRIER	BRIDEDECKEL	1
3	25547012/0	PIASTRINA	PLATE	PLAQUE	PLATTE	1
4	12731601/0	VITE	SCREW	VIS	SCHRAUBE	4
5	25033005/0	ASTA	ROD	BARRE	STANGE	1
6	12521350/0	RONDELLA	WASHER	RONDELLE	SCHEIBE	2
7	12155000/0	DADO	NUT	ECROU	MUTTER	1
8	82394500/0	ASS. MANOPOLA FRENO	BRAKE KNOB ASS.Y	ENS. POIGNEE DE FREIN	BREMSEKNOPF	1
9	25033007/0	ASTA COMANDO FRENO CAMBIO	BRAKE CONTROL ASS.Y	ENSEMBLE CONTROLE FREIN	BREMSE KONTROLLESATZ	1
10	12154510/0	DADO	NUT	ECROU	MUTTER	2
11	25430212/1	MOLLA	SPRING	RESSORT	FEDER	1
12	25510017/0	PERNO	PIN	PIVOT	BOLZEN	1
13	12155000/0	DADO	NUT	ECROU	MUTTER	1
14	25430213/0	MOLLA RICHIAMO FRENO	SPRING BRAKE	RESSORT FREIN	FEDER BREMSE	1
15	12155000/0	DADO	NUT	ECROU	MUTTER	1
16	12521330/0	RONDELLA	WASHER	RONDELLE	SCHEIBE	1
31	82394502/0	ASS. MANOPOLA CAMBIO	GEARBOX KNOB ASS.Y	POIGNEE BOITE DE VITESSE	WECHSELGETRIEBE	1
32	25318111/1	LEVA COMANDO CAMBIO	GEARSHIFT	LEVIER CHANGEMENT VITESSE	DEGETRIEBE HEBEL	1
33	25670007/0	RONDELLA	WASHER	RONDELLE	SCHEIBE	1
34	12155000/0	DADO	NUT	ECROU	MUTTER	1

Pos. Nr.	Codice Kodex Code	Descrizione	Description	Description	Beschreibung	Q.tà Q.ty Q.té Menge
35	82869003/0	ASS. TUBO COMANDO	SPEED DRIVE TUBE	TUBE COMMANDE CHANGE- MARCEMENT DE VITESSE	GAENGESCHALTUNG ROHR	1
36	25040602/0	BUSSOLA	BUSH	DOUILLE	BÜCHSE	2
37	25670006/0	RONDELLA	WASHER	RONDELLE	SCHEIBE	2
38	12001000/0	SEEGER	SEEGER	SEEGER	SEEGER	2
39	25040601/0	BUSSOLA	BUSH	DOUILLE	BÜCHSE	2
40	25033004/0	ASTA	ROD	BARRE	STANGE	1
41	22746601/0	SNODO M8	JOINT M8	JOINT M8	GELENK M8	1
42	12293200/0	DADO	NUT	ECROU	MUTTER	1
43	12293200/0	DADO	NUT	ECROU	MUTTER	1
44	12141418/0	COPPIGLIA	COTTER PIN	GOUVILLE	SPLIT	
45	25318117/0	LEVA CAMBIO	GEARSHIFT	LEVIER CHANGEMENT DE VITESSE	GETRIEBE HEBEL	1
46	12689500/0	VITE	SCREW	VIS	SCHRAUBE	1
47	12521330/0	RONDELLA	WASHER	RONDELLE	SCHEIBE	2
48	12154510/0	DADO	NUT	ECROU	MUTTER	1
49	12583500/0	GROWER	GROWER	GROWER	GROWER	1

GRUPPO MOTORE 12,5 HP B&S
 ENGINE ASS.Y 12.5 HP B&S
 GROUPE MOTEUR 12,5 HP B&S
 MOTORSATZ 12,5 HP B&S

Mod. 1996

005

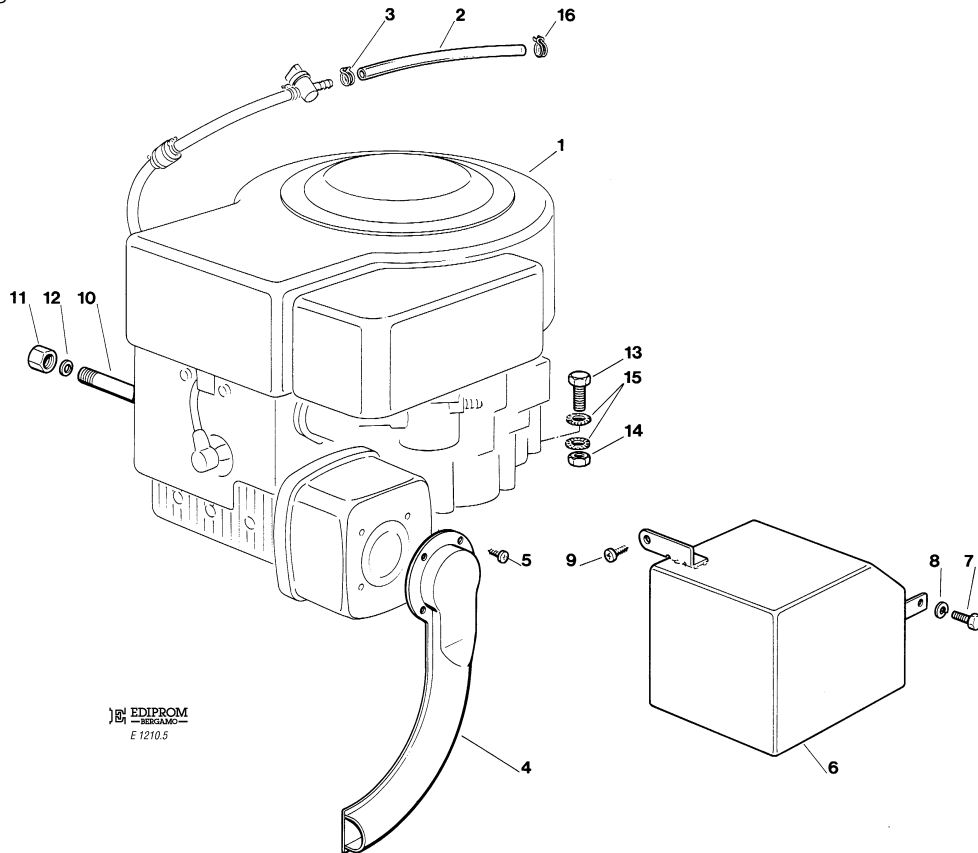

Pos. Nr.	Codice Kodex Code	Descrizione	Description	Description	Beschreibung	Q.tà Q.ty Q.té Menge
1*	—	MOTORE	ENGINE	MOTEUR	MOTOR	1
2	25869003/0	TUBO COLLEGAMENTO	CONNECTING TUBE	TUBE DE CONNEXION	VERBINDUNGSROHR	1
3	18375051/0	FASCETTA	FAIR LED	FIXATION DE CABLE	KABELBEFESTIGUNG	3
4*	82640001/1	ASS. RACCORDO SCARICO	EXHAUST CONNECTION	CONNEXION ECHAPPEMENT	AUSPUFFANSCHLUSS	1
5	12735106/0	VITE	SCREW	VIS	SCHRAUBE	4
6	82598001/0	ASS. PROTEZIONE SILENZIATORE	MUFFLER PROTECTION ASS.Y	PROTECTION SILENCIEUX	AUSPUFFSCHUTZ	1
7	12735510/0	VITE	SCREW	VIS	SCHRAUBE	1
8	12582100/0	GROWER	GROWER	GROWER	GROWER	1
9	12735104/0	VITE	SCREW	VIS	SCHRAUBE	1
10	25598050/0	PROLUNGA SCARICO OLIO	OIL DISCHARGE EXTENSION	RALLONGE DE DECHAR- MENT HUILE	ÖL ENTLEERUNGSVERLAEN- GERUNG	1
11	18737849/0	TAPPO PER PROLUNGA	OIL CAP	BOUCHON HUILE	OELVERSCHLUSS	1
12	18401001/0	GUARNIZIONE	OIL SEAL	GARNITURE	DICHTUNG	1
13	12793600/0	VITE	SCREW	VIS	SCHRAUBE	4
14	12293200/0	DADO	NUT	ECROU	MUTTER	1
	12293201/0	DADO	NUT	ECROU	MUTTER	3
15	12540260/0	RONDELLA	WASHER	RONDELLE	SCHEIBE	2
16	18375052/0	FASCETTA	FAIR LED	FIXATION DE CABLE	KABELBEFESTIGUNG	1

DOVENDO SOSTITUIRE IN GARANZIA LE PARTI CONTRASSEGNAE CON «*» RIVOLGERSI AL COSTRUTTORE DEL MOTORE.

IF YOU HAVE TO CHANGE THE PIECES INDICATED WITH «*» ON WARRANTY YOU ADDRESS TO AFTER SALES SERVICE OF ENGINE MANUFACTURER.

SI VOUS DEVEZ SUBSTITUER LES PIÈCES INDIQUÉES AVEC «*» SOUS GARANTIE VOUS DEVEZ VOUS ADRESSER AU SERVICE APRÈS VENTES DE LA MAISON CONSTRUCTRICE DU MOTEUR.

BITTE WENDEN SIE SICH BEI GARANTIERPARATUREN DER MIT «*» GEKENNZEICHNETEN TEILE AN DIE KUNDENDIESNSTELLE DES MOTORHERSTELLER.

GRUPPO MOTORE 16 HP B&S
 ENGINE ASS.Y 16 HP B&S
 GROUPE MOTEUR 16 HP B&S
 MOTORSATZ 16 HP B&S

Mod. 1996 **005a**

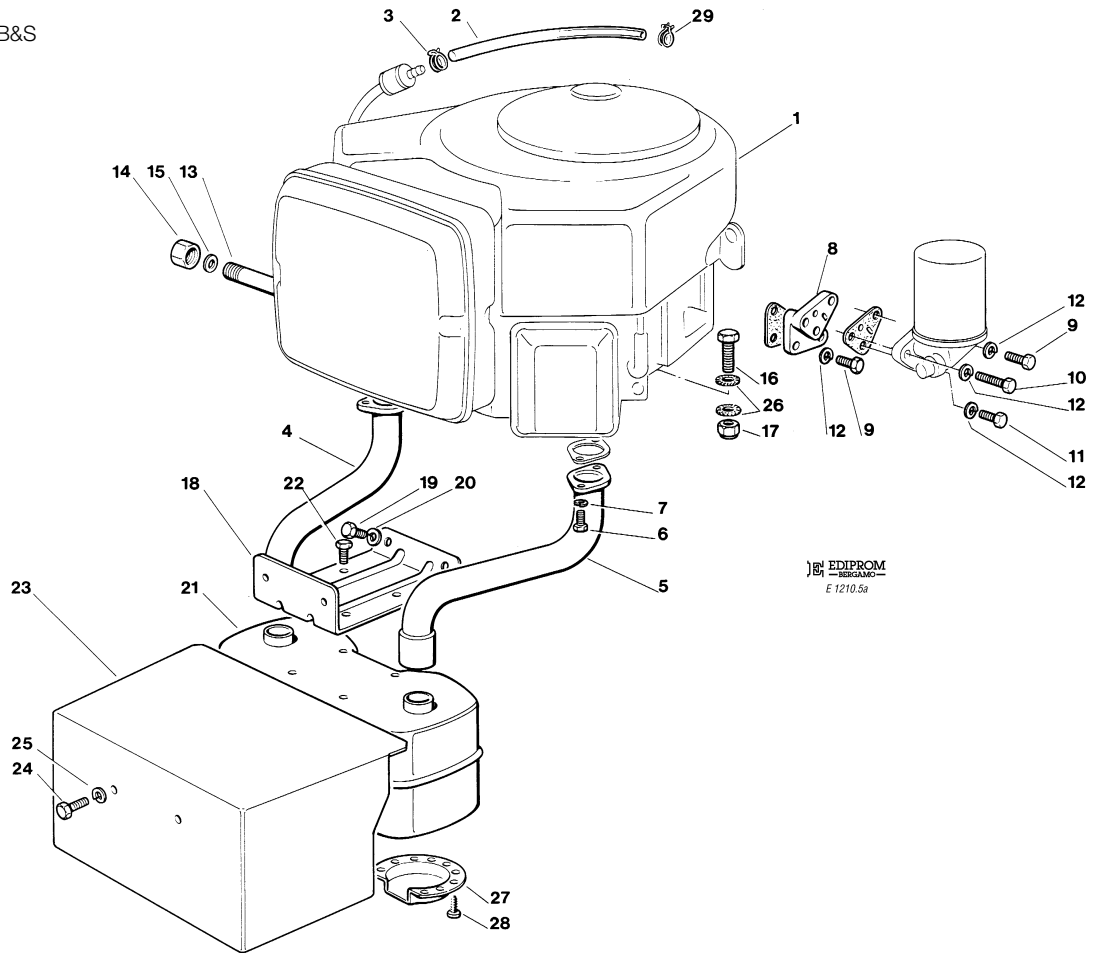

Pos. Nr.	Codice Kodex Code	Descrizione	Description	Description	Beschreibung	Q.tà Q.ty Q.té Menge
1*	—	MOTORE	ENGINE	MOTEUR	MOTOR	1
2	25869004/0	TUBO COLLEGAMENTO	CONNECTING TUBE	TUBE DE CONNEXION	VERBINDUNGSROHR	1
3	18375051/0	FASCETTA	FAIR LED	FIXATION DE CABLE	KABELBEFESTIGUNG	1
4*	18738202/0	TUBO RACCORDO SCARICO DX	EXHAUST RIGHT CONNECTING TUBE	TUBE DE CONNEXION DROIT POUR ECHAPP.	RECHTES VERBINDUNGSROHR FÜR ABGASUNG	1
5*	18738203/0	TUBO RACCORDO SCARICO SX	EXAUST LEFT CONNECTING TUBE	TUBE DE CONNEXION GAUCHE POUR ECHAPP.	LINKES VERBINDUNGSROHR FÜR ABGASUNG	1
6	12793101/0	VITE	SCREW	VIS	SCHRAUBE	4
7	12583500/0	GROWER	GROWER	GROWER	GROWER	4
8	25785095/0	SUPPORTO FILTRO	FILTER SUPPORT	SUPPORTE DU FILTRE	WECHSELFILTER HALTER	1
9	12791400/0	VITE	SCREW	VIS	SCHRAUBE	3
10	12689515/0	VITE	SCREW	VIS	SCHRAUBE	1
11	12791213/0	VITE	SCREW	VIS	SCHRAUBE	1
12	12582100/0	GROWER	GROWER	GROWER	GROWER	5
13	25598050/0	PROLUNGA SCARICO OLIO	OIL DISCHARGE EXTENSION	EXTENSION RALLONGE DE DESCHERG. HUILE	ENTLERUNGSVERLAENGERUNG	1
14	18737849/0	TAPPO PROLUNGA	OIL CAP	BOUCHON HUILE	OELVERSCHLUSS	1
15	18401001/0	GUARNIZIONE	OIL SEAL	GARNITURE	DICHTUNG	1
16	12793600/0	VITE	SCREW	VIS	SCHRAUBE	4
17	12293201/0	DADO	NUT	ECROU	MUTTER	3
	12293200/0	DADO	NUT	ECROU	MUTTER	1
18	82785093/0	ASS. SUPPORTO SILENZIATORE	MUFFLER SUPPORT ASS.Y	GROUPS SUPPORT SILENCEUX	AUSPUFFHALTER	1
19	12793101/0	VITE	SCREW	VIS	SCHRAUBE	2
20	12583500/0	GROWER	GROWER	GROWER	GROWER	2

Pos. Nr.	Codice Kodex Code	Descrizione	Description	Description	Beschreibung	Q.tà Q.ty Q.té Menge
21*	18716131/1	SILENZIATORE COMPLETO DI DEFLETTORE	MUFFLER WITH DEFLECTOR	SILENCEUX AVEC DEFLECTEUR	AUSPUFF MIT DEFLEKTOR	1
22	12735107/0	VITE	SCREW	VIS	SCHRAUBE	4
23	82598005/0	PROTEZIONE	GUARD	PROTECTION	SCHUTZE	1
24	12792610/0	VITE	SCREW	VIS	SCHRAUBE	2
25	12583500/0	GROWER	GROWER	GROWER	GROWER	2
26	12540260/0	RONDELLA	WASHER	RONDELLE	SCHEIBE	2
27	18310005/0	DEFLETTORE	DEFLECTOR	DEFLECTEUR	DEFLEKTOR	1
28	12735106/0	VITE	SCREW	VIS	SCHRAUBE	4
29	18375052/0	FASCETTA	FAIR LED	FIXATION DE CABLE	KABELBEFESTIGUNG	1

DOVENDO SOSTITUIRE IN GARANZIA LE PARTI CONTRASSEGNAE CON «*» RIVOLGERSI AL COSTRUTTORE DEL MOTORE.

IF YOU HAVE TO CHANGE THE PIECES INDICATED WITH «*» ON WARRANTY YOU ADRESS TO AFTER SALES SERVICE OF ENGINE MANUFACTURER.

SI VOUS DEVEZ SUBSTITUER LES PIÈCES INDIQUÉES AVEC «*» SOUS GARANTIE VOUS DEVEZ VOUS ADRESSER AU SERVICE APRÈS VENTES DE LA MAISON CONSTRUCTRICE DU MOTEUR.

BITTE WENDEN SIE SICH BEI GARANTIERPARATUREN DER MIT «*» GEKENNZEICHNETEN TEILE AN DIE KUNDENDIESNSTSTELLE DES MOTORHERSTELLER.

GRUPPO MOTORE 15,5 HP KOHLER
 ENGINE ASS.Y 15,5 HP KOHLER
 GROUPE MOTEUR 15,5 HP KOHLER
 MOTORSATZ 15,5 HP KOHLER

Mod. 1996 **005b**

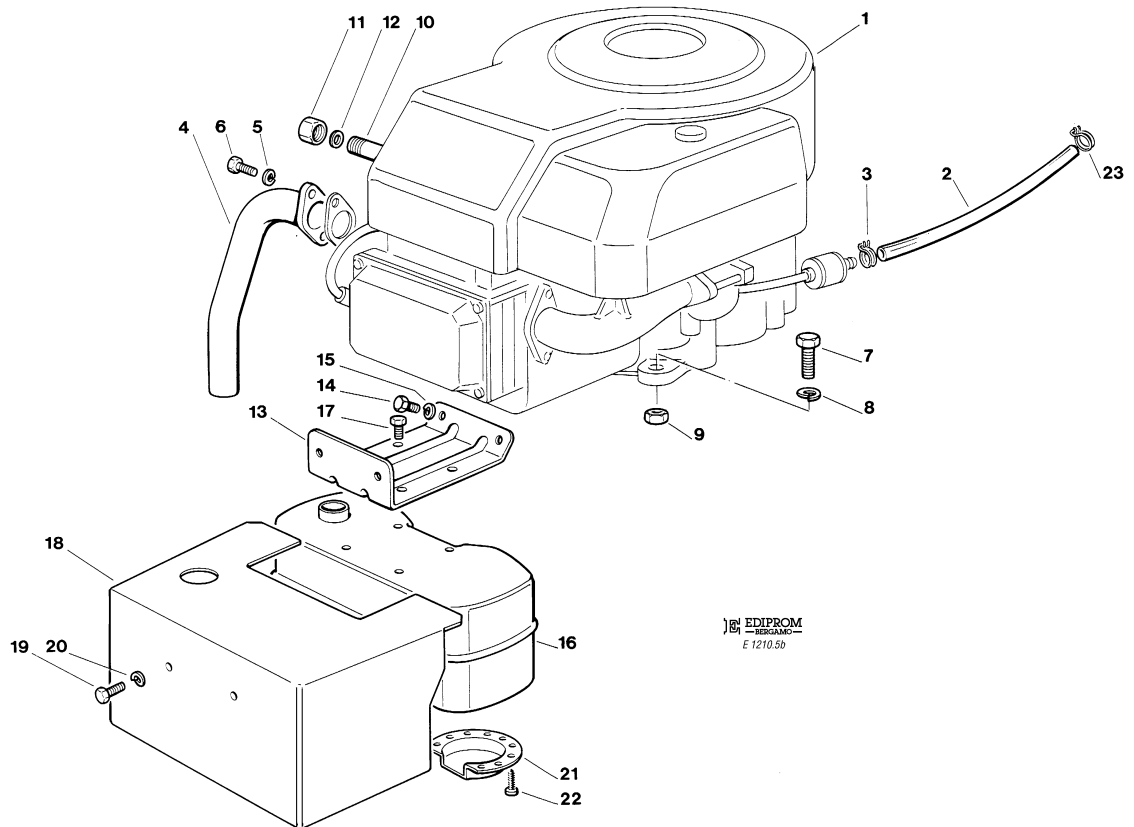

Pos. Nr.	Codice Kodex Code	Descrizione	Description	Description	Beschreibung	Q.tà Q.ty Q.té Menge
1*	—	MOTORE	ENGINE	MOTEUR	MOTOR	1
2	25869011/0	TUBO COLLEGAMENTO	CONNECTING TUBE	TUBE DE CONNEXION	VERBINDUNGSROHR	1
3	18375051/0	FASCETTA	FAIR LED	FIXATION DE CABLE	KABELBEFESTIGUNG	1
4*	18738206/0	TUBO RACCORDO SCARICO	EXHAUST CONNECTING TUBE	TUBE DE CONNEXION POUR ECHAPPEMENT	VERBINDUNGSROHR FÜR ABGASUNG	1
5	12735500/0	GROWER	GROWER	GROWER	GROWER	2
6	12735530/0	VITE	SCREW	VIS	SCHRAUBE	2
7	12793600/0	VITE	SCREW	VIS	SCHRAUBE	4
8	12540260/0	GROWER	GROWER	GROWER	GROWER	4
9	12293200/0	DADO	NUT	ECROU	MUTTER	1
10	25598050/0	PROLUNGA SCARICO OLIO	OIL DISCHARGE	EXTENSION RALLONGE DE DESCHERG. HUILE	ENTLERUNGSVERLAEN- GERUNG	1
11	18737849/0	TAPPO PROLUNGA	OIL CAP	BOUCHON HUILE	OELVERSCHLUSS	1
12	18401001/0	GUARNIZIONE	OIL SEAL	GARNITURE	DICHTUNG	1
13	82785093/0	ASS. SUPPORTO SILENZIATORE	MUFFLER SUPPORT ASS.Y	GROUPS SUPPORT SILENCEUX	AUSPUFFHALTER	1
14	12793101/0	VITE	SCREW	VIS	SCHRAUBE	2
15	12583500/0	GROWER	GROWER	GROWER	GROWER	2
16	18716132/0	SILENZIATORE COMPLETO DI DEFLETTORE	MUFFLER WITH DEFLECTOR	SILENCEUX AVEC DEFLECTEUR	AUSPUFF MIT DEFLEKTOR	1
17	12735107/0	VITE	SCREW	VIS	SCHRAUBE	4
18	82598009/0	PROTEZIONE	GUARD	PROTECTION	SCHUTZE	1
19	12792610/0	VITE	SCREW	VIS	SCHRAUBE	2

Pos. Nr.	Codice Kodex Code	Descrizione	Description	Description	Beschreibung	Q.tà Q.ty Q.té Menge
20	12583500/0	GROWER	GROWER	GROWER	GROWER	2
21	18310005/0	DEFLETTORE	DEFLECTOR	DEFLECTEUR	DEFLEKTOR	1
22	12735106/0	VITE	SCREW	VIS	SCHRAUBE	4
23	18375052/0	FASCETTA	FAIR LED	FIXATION DE CABLE	KABELBEFESTIGUNG	1

DOVENDO SOSTITUIRE IN GARANZIA LE PARTI CONTRASSEGNAE CON «*» RIVOLGERSI AL COSTRUTTORE DEL MOTORE.

IF YOU HAVE TO CHANGE THE PIECES INDICATED WITH «*» ON WARRANTY YOU ADRESS TO AFTER SALES SERVICE OF ENGINE MANUFACTURER.

SI VOUS DEVEZ SUBSTITUER LES PIÈCES INDIQUÉES AVEC «*» SOUS GARANTIE VOUS DEVEZ VOUS ADRESSER AU SERVICE APRÈS VENTES DE LA MAISON CONSTRUCTRICE DU MOTEUR.

BITTE WENDEN SIE SICH BEI GARANTIERPARATUREN DER MIT «*» GEKENNZEICHNETEN TEILE AN DIE KUNDENDIESNSTSTELLE DES MOTORHERSTELLER.

GRUPPO CAMBIO E TRASMISSIONE
 GEARBOX AND TRANSMISSION GROUP
 GROUPE CHANGEMENT DE VITESSE
 WECHSEL UND ANTRIEB

Mod. 1996

006

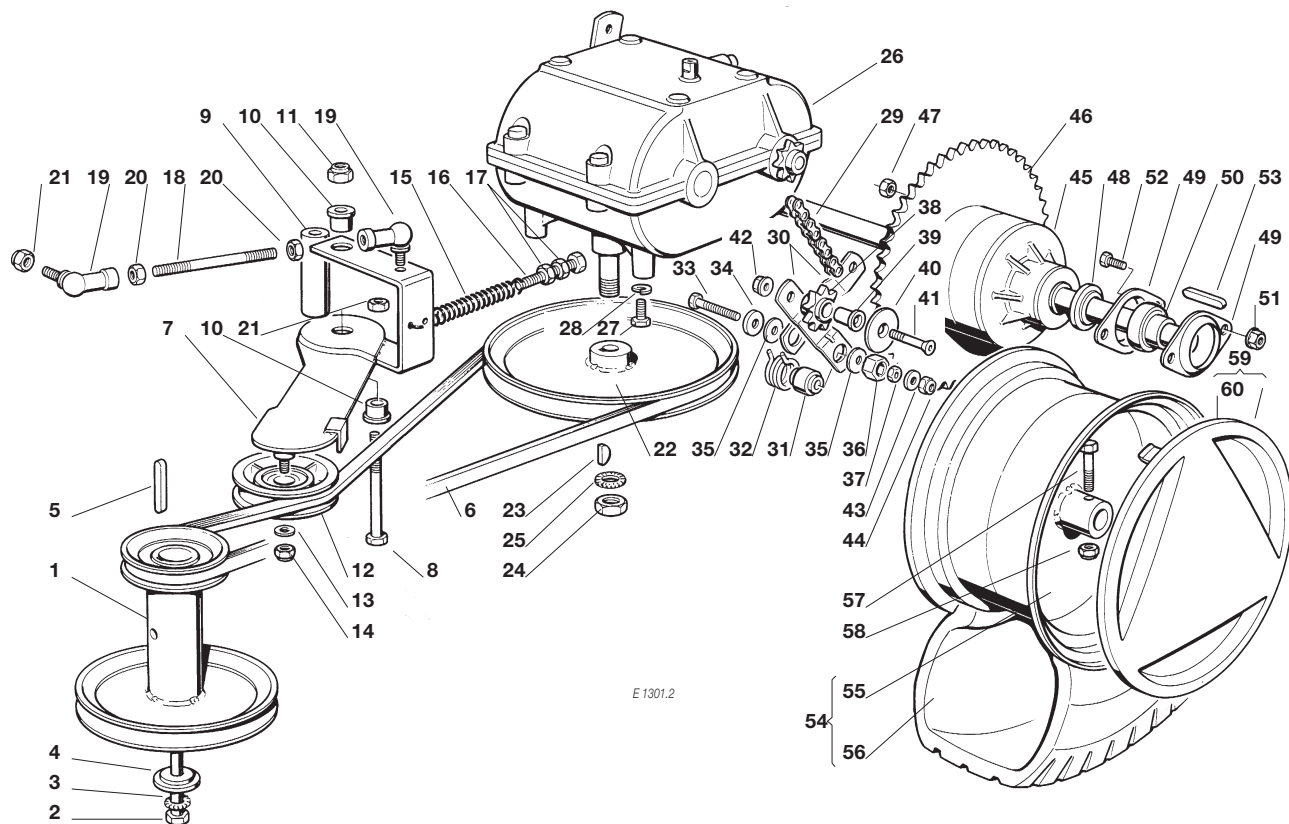

E 1301.2

Pos. Nr.	Codice Kodex Code	Descrizione	Description	Description	Beschreibung	Q.tà Q.ty Q.té Menge
1	25601552/0	ASS. PULEGGIA MOTORE	ENGINE PULLEY ASS.Y	ENS. POULIE MOTEUR	RIEMENSCHLEIBE	1
2	12737310/0	VITE (12,5-16 HP B&S)	SCREW (12,5-16 HP B&S)	VIS (12,5-16 HP B&S)	SCHRAUBE (12,5-16 HP B&S)	1
	12692330/0	VITE (14 HP KOHLER)	SCREW (14 HP KOHLER)	VIS (14 HP KOHLER)	SCHRAUBE (14 HP KOHLER)	1
	12737310/0	VITE (18 HP KOHLER)	SCREW (18 HP KOHLER)	VIS (18 HP KOHLER)	SCHRAUBE (18 HP KOHLER)	1
3	12543000/0	RONDELLA	WASHER	RONDELLE	SCHEIBE	1
4	22671433/0	BOCCOLA	BUSHING	DOUILLE	BÜCHSE	1
5	12139490/0	CHIAVETTA	KEY	CLAVETTE	KEIL	1
6	35061502/0	CINGHIA	BELT	COURROIE	RIEMEN	1
7	82318111/1	ASS. LEVA GALOPPINO	TIGHTENER LEVER	LEVIER GALOPIN	LEIT ROLLE	1
8	12692080/0	VITE	SCREW	VIS	SCHRAUBE	1
9	25160008/0	DISTANZIALE	SPACER	ENTRETOISE	ENTFERNUNGSSTUECK	1
10	25038002/0	BOCCOLA	BUSHING	DOUILLE	BÜCHSE	2
11	12155000/0	DADO	NUT	ECROU	MUTTER	1
12	25601554/0	PULEGGIA	PULLEY	POULIE	RIEMENSCHLEIBE	1
13	12523060/0	RONDELLA	WASHER	RONDELLE	SCHEIBE	1
14	12155000/0	DADO	NUT	ECROU	MUTTER	1
15	25430219/0	MOLLA	SPRING	RESSORT	FEDER	1
16	22943005/0	VITE	SCREW	VIS	SCHRAUBE	1
17	12293200/0	DADO	NUT	ECROU	MUTTER	2
18	25598002/0	PRIGIONIERO	STUD SCREW	PRISONNIER	STIFTSCHLEIBE	1
19	22746601/0	SNODO M8	JOINT M8	JOINT M8	GELENK M8	2
20	12293200/0	DADO	NUT	ECROU	MUTTER	2
21	12155000/0	DADO	NUT	ECROU	MUTTER	2
22	25601553/0	PULEGGIA	PULLEY	POULIE	RIEMENSCHLEIBE	1
23	12138810/0	LINGUETTA	KEY	CLAVETTE	KEIL	1
24	12361010/0	DADO	NUT	ECROU	MUTTER	1

Pos. Nr.	Codice Kodex Code	Descrizione	Description	Description	Beschreibung	Q.tà Q.ty Q.té Menge
25	12540280/0	RONDELLA	WASHER	RONDELLE	SCHEIBE	1
26*	18159002/0	CAMBIO	GEAR BOX	BOÎTE DE VITESSE	GETRIEBE	1
27	12735530/0	VITE	SCREW	VIS	SCHRAUBE	4
28	12583500/0	GROWER	GROWER	GROWER	GROWER	4
29	15189001/0	CATENA	CHAIN	CHAÎNE	KETTE	1
30	25318122/0	LEVA FLOTTANTE	FLOATING LEVER	LEVIER	HEBEL	2
31	25040607/0	BUSSOLA	BUSH	DOUILLE	BUCHSE	1
32	25430207/0	MOLLA	SPRING	RESSORT	FEDER	1
33	12793905/0	VITE	SCREW	VIS	SCHRAUBE	1
34	12523070/0	ROSETTA	WASHER	RONDELLE	SCHEIBE	1
35	22672152/0	RONDELLA ANTIFRIZIONE	WASHER	RONDELLE	SCHEIBE	2
36	25160006/0	DISTANZIALE	SPACER	ENTRETOISE	ENTFERNUNGSSTÜCK	1
37	12293200/0	DADO	NUT	ECROU	MUTTER	1
38	25570001/0	PIGNONE	PINION	PIGNON	RITZEL	2
39	25040608/0	BUSSOLA	BUSH	DOUILLE	BUCHSE	2
40	25670009/0	RONDELLA	WASHER	RONDELLE	SCHEIBE	2
41	12882020/0	VITE	SCREW	VIS	SCHRAUBE	2
42	12155000/0	DADO	NUT	ECROU	MUTTER	2
43	12524010/0	ROSETTA	WASHER	RONDELLE	SCHEIBE	1
44	12155000/0	DADO	NUT	ECROU	MUTTER	1
45*	25140200/2	DIFFERENZIALE	DIFFERENTIAL GEAR	DIFFERENTIEL	DIFFERENTIAL	1
46	16694600/1	CORONA	RING GEAR	COURONNE	KRANZ	1
47	12360354/1	DADO	NUT	ECROU	MUTTER	4
48	25160010/0	DISTANZIALE	SPACER	ENTRETOISE	ENTFERNUNGSSTÜCK	2
49	22207319/0	FLANGIA	FLANGE	BRIDE	FLANSCH	6
50	25122201/0	CUSCINETTO	BEARING	COUSSINET	KUGELLAGER	3
51	12293201/0	DADO	NUT	ECROU	MUTTER	4
52	12793301/0	VITE	SCREW	VIS	SCHRAUBE	2
53	24451425/0	CHIAVETTA	KEY	CLAVETTE	KEIL	2
54	82680001/0	RUOTA COMPLETA (TURF-SAVER)	WHEEL ASS.Y (TURF-SAVER)	ENSEMBLE ROUE (TURF-SAVER)	RAD (TURF-SAVER)	2
55	82000591/0	ASS. CERCHIO RUOTA POST.	REAR RIMM ASS.Y	BANDAGE ROUE POST.	HINTERRAD FELGER	2
56	25590001/0	PNEUMATICO (TURF-SAVER)	SHOE (TURF-SAVER)	PNEU (TURF-SAVER)	REIFEN (TURF-SAVER)	2
57	12691200/0	VITE	SCREW	VIS	SCHRAUBE	2
58	12155000/0	DADO	NUT	ECROU	MUTTER	2
59	82110251/1	COPRIRUOTA POST. (TC)	REAR WHEEL DECK (TC)	COUVRE ROUE POST. (TC)	HINTERRADDECKEL (TC)	2
	82110253/0	COPRIRUOTA POST. (TCP)	REAR WHEEL DECK (TCP)	COUVRE ROUE POST. (TCP)	HINTERRADDECKEL (TCP)	2
60	25430209/0	MOLLA AGGANCIO	SPRING	RESSORT	FEDER	8

DOVENDO SOSTITUIRE IN GARANZIA LE PARTI CONTRASSEGNAE CON «*» RIVOLGERSI AL COSTRUTTORE DEL MOTORE.

IF YOU HAVE TO CHANGE THE PIECES INDICATED WITH «*» ON WARRANTY YOU ADRESS TO AFTER SALES SERVICE OF ENGINE MANUFACTURER.

SI VOUS DEVEZ SUBSTITUER LES PIÈCES INDIQUÉES AVEC «*» SOUS GARANTIE VOUS DEVEZ VOUS ADRESSER AU SERVICE APRÈS VENTES DE LA MAISON CONSTRUCTRICE DU MOTEUR.

BITTE WENDEN SIE SICH BEI GARANTIERPARATUREN DER MIT«*» GEKENNZEICHNETEN TEILE AN DIE KUNDENDIESNSTSTELLE DES MOTORHERSTELLER.

GRUPPO SOLLEVAMENTO PIATTO
 CUTTING PLATE LIFTING ASS.Y
 ENS. SOULEVEMENT PLATEAU DE COUPE
 SCHNEIDWERKZEUG AUFHEBESATZ

Mod. 1996

007

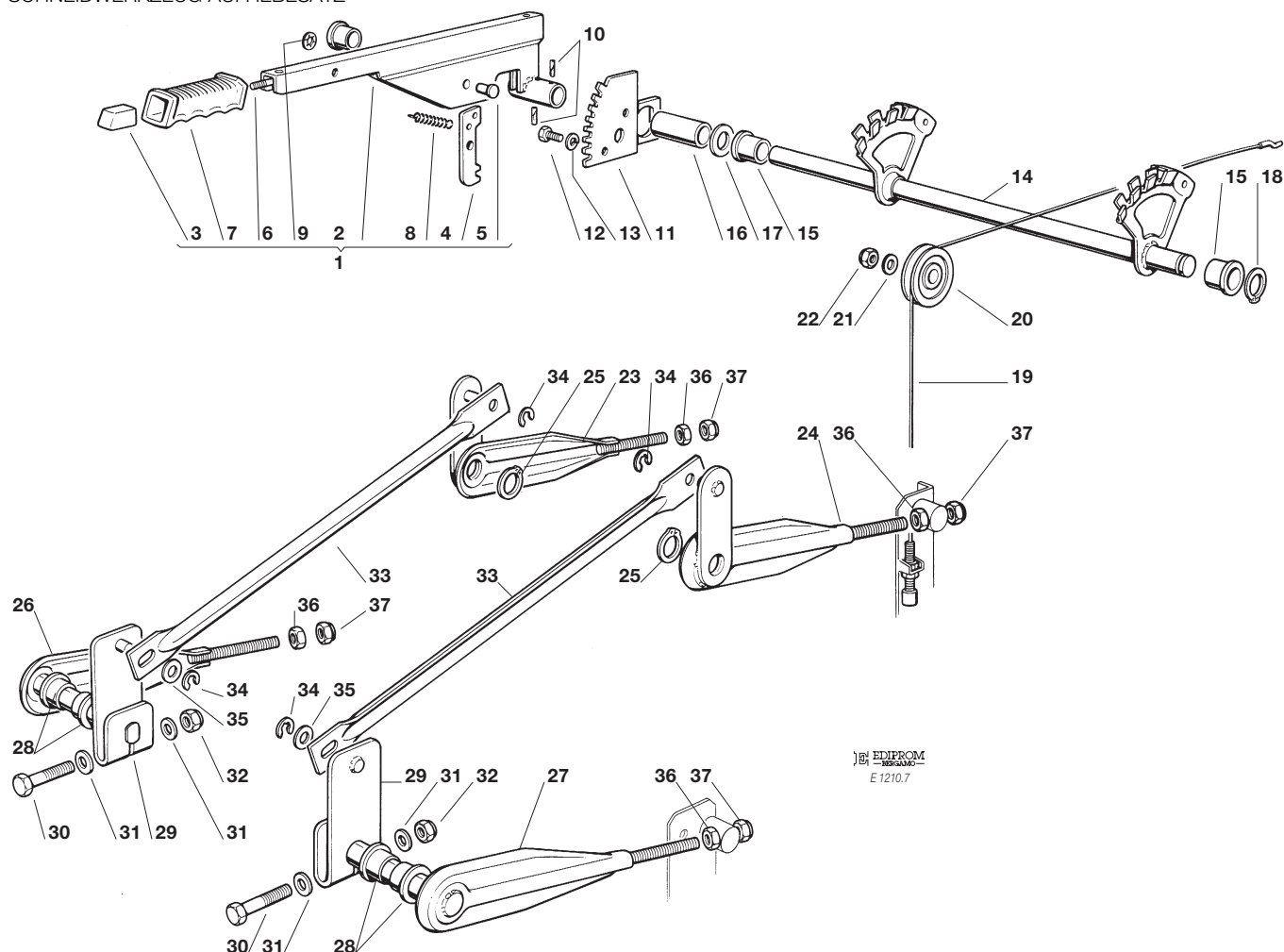

Pos. Nr.	Codice Kodex Code	Descrizione	Description	Description	Beschreibung	Q.tà Q.ty Q.té Menge
1	82300000/0	ASS. GRUPPO LEVA SOLLEVAMENTO PIATTO	LIFTING LEVER ASS.Y	ENS. LEVIER SOULEVEMENT PLATEAU DE COUPE	SCHNEIDWERKZEUG AUFHEBENHEBEL	1
2	82318103/0	LEVA SOLLEVAMENTO	LIFTING LEVER	LEVIER DE SOULEVEMENT	AUFHEBENHEBEL	1
3	82605000/0	PULSANTE	BUTTON	POUSSOIR	DRUCKKNOPF	1
4	25470901/0	NASELLO	DOG	DECLIC	NASE	1
5	25510011/0	PERNO	PIN	PIVOT	BOLZEN	1
6	25033002/0	ASTA COMANDO	PUSHROD	TIGE COMMANDE	BETAETIGUNGSSTAB	1
7	25394504/0	MANOPOLA	KNOB	POIGNEE	GRIF	1
8	25430208/0	MOLLA	SPRING	RESSORT	FEDER	1
9	12604899/0	RONDELLA	WASHER	RONDELLE	SCHEIBE	1
10	12620206/0	SPINA	PIN	GOUPILLE	STIFT	1
11	25735501/0	SETTORE REGOLAZIONE	ADJ. SECTOR	SECTEUR REGLEMENT	EINSTELLESEKTOR	1
12	12792611/0	VITE	SCREW	VIS	SCHRAUBE	2
13	12583500/0	GROWER	GROWER	GROWER	GROWER	2
14	82000401/0	ASS. ASSE SOLLEVAMENTO	LIFTING SHAFT	ARBRE SOULEVEMENT	AUFHEBENACHSE	1
15	22034523/0	BOCCOLA	BUSH	DOUILLE	BÜCHSE	3
16	25160004/0	DISTANZIALE	SPACER	ENTRETOISE	ENTFERNUNGSSTUECK	1
17	12521410/0	RONDELLA	WASHER	RONDELLE	SCHEIBE	1
18	12609260/0	SEEGER	SEEGER	SEEGER	SEEGER	1
19	82004600/0	ASS. FILO SOLLEVAMENTO	LIFTING WIRE	ENS. FIL SOULEVEMENT	AUFHEBENKABEL	2
20	25601557/0	PULEGGIA	PULLEY	POULIE	SCHEIBE	2
21	12521350/0	RONDELLA	WASHER	RONDELLE	SCHEIBE	2
22	12155000/0	DADO	NUT	ECROU	MUTTER	2

Pos. Nr.	Codice Kodex Code	Descrizione	Description	Description	Beschreibung	Q.tà Q.ty Q.té Menge
23	82318105/0	LEVA FULCRO DX (TC(P) 102)	RIGHT FULCRUM LEVER (TC(P) 102)	LEVIER POINT D'APPUI DROITE (TC(P) 102)	RECHTER SCHWENKPUNKT HEBEL (TC(P) 102)	1
	82318119/0	LEVA FULCRO DX (TC(P) 122)	RIGHT FULCRUM LEVER (TC(P) 122)	LEVIER POINT D'APPUI DROITE (TC(P) 122)	RECHTER SCHWENKPUNKT HEBEL (TC(P) 122)	1
24	82318107/0	LEVA FULCRO SX (TC(P) 102)	LEFT FULCRUM LEVER (TC(P) 102)	LEVIER POINT D'APPUI GAUCHE (TC(P) 102)	LINKER SCHWENKPUNKT HEBEL (TC(P) 102)	1
	82318121/0	LEVA FULCRO SX (TC(P) 122)	LEFT FULCRUM LEVER (TC(P) 122)	LEVIER POINT D'APPUI GAUCHE (TC(P) 122)	LINKER SCHWENKPUNKT HEBEL (TC(P) 122)	1
25	12609255/0	ANELLO	RING	ANNEAU	RING	2
26	82318115/0	LEVA FULCRO ANTERIORE DX (TC(P) 102)	FRONT FULCRUM LEVER RIGHT (TC(P) 102)	LEVIER POINT D'APPUI ANT. DROITE (TC(P) 102)	RECHTER VORDERSCHWENK- PUNKTHEBEL (TC(P) 102)	1
	82318123/0	LEVA FULCRO ANTERIORE DX (TC(P) 122)	FRONT FULCRUM LEVER RIGHT (TC(P) 122)	LEVIER POINT D'APPUI ANT. DROITE (TC(P) 122)	RECHTER VORDERSCHWENK- PUNKTHEBEL (TC(P) 122)	1
27	82318117/0	LEVA FULCRO ANTERIORE SX (TC(P) 102)	FRONT FULCRUM LEVER LEFT (TC(P) 102)	LEVIER POINT D'APPUI ANT. GAUCHE (TC(P) 102)	LINKER VORDERSCHWENK- PUNKTHEBEL (TC(P) 102)	1
	82318125/0	LEVA FULCRO ANTERIORE SX (TC(P) 122)	FRONT FULCRUM LEVER LEFT (TC(P) 122)	LEVIER POINT D'APPUI ANT. GAUCHE (TC(P) 122)	LINKER VORDERSCHWENK- PUNKTHEBEL (TC(P) 122)	1
28	25040605/0	BUSSOLA	BUSH	DOUILLE	BÜCHSE	4
29	82318109/0	ASS. LEVA ASTA COLLEGAMENTO	CONNECTING ROD LEVER	LEVIER TIGE DE CONNEXION	VERBINDUNGSSTAB HEBEL	2
30	12691700/0	VITE	SCREW	VIS	SCHRAUBE	2
31	12521350/0	RONDELLA	WASHER	RONDELLE	SCHEIBE	4
32	12155000/0	DADO	NUT	ECROU	MUTTER	2
33	25033001/0	ASTA COLLEGAMENTO	CONNECTING ROD	TIGE DE CONNEXION	VERBINDUNGSSTAB	2
34	12000955/0	ANELLO ELASTICO	SNAP RING	ANNEAU RESSORT	SPRENGRING	4
35	25670008/0	RONDELLA	WASHER	RONDELLE	SCHEIBE	2
36	12295200/0	DADO	NUT	ECROU	MUTTER	4
37	12156602/0	DADO	NUT	ECROU	MUTTER	4

GRUPPO PIATTO DI TAGLIO (1)
 CUTTING PLATE GROUP (1)
 GROUPE PLATEAU DE COUPE (1)
 SCHNEIDWERKZEUG (1)

Mod. 1996 **008**

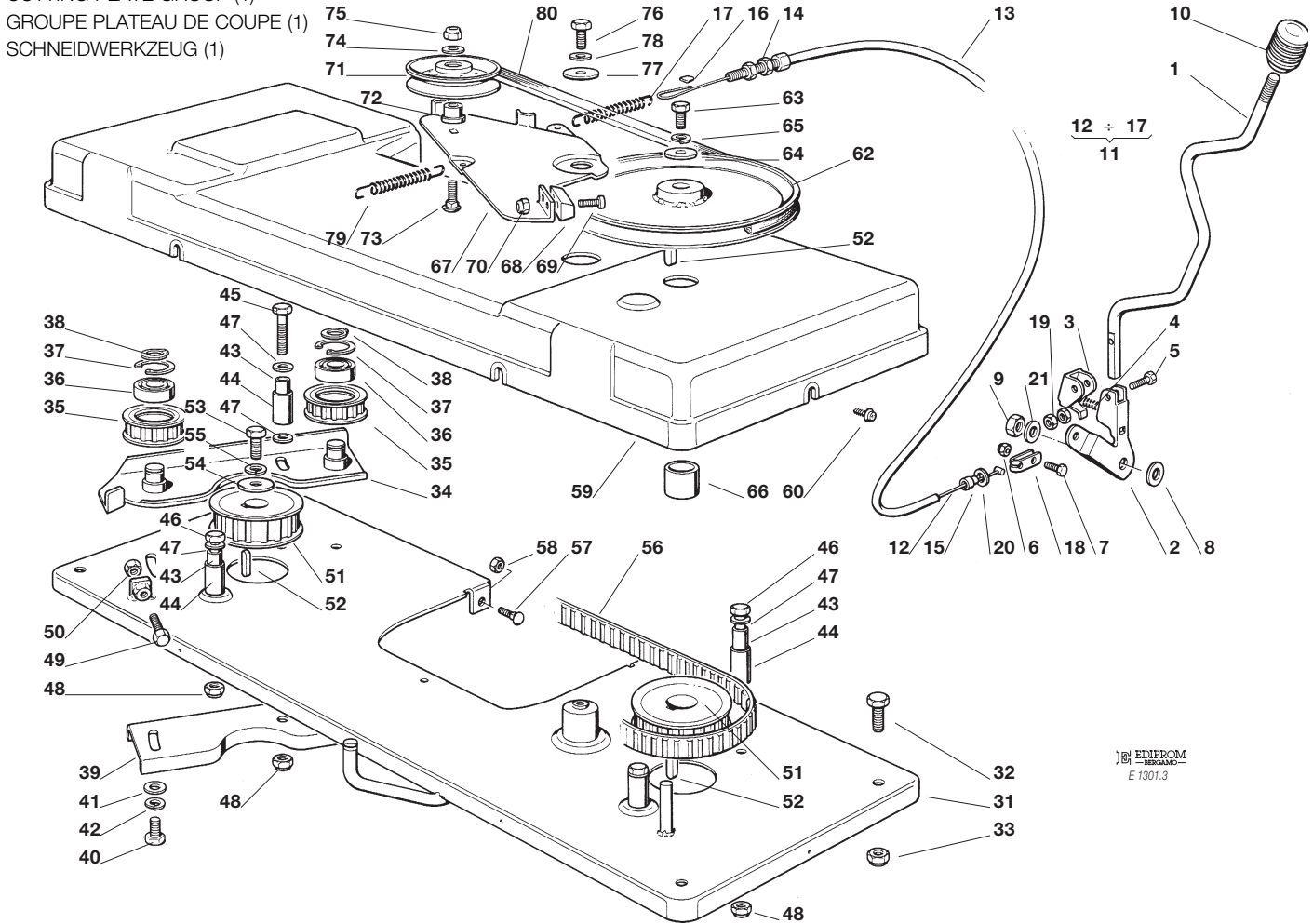

Pos. Nr.	Codice Kodex Code	Descrizione	Description	Description	Beschreibung	Q.tà Q.ty Q.té Menge
1	25318120/0	LEVA INNESTO	ENGAGING LEVER	LEVIER D'EMBRAYAGE	EINSCHALTENHEBEL	1
2	82774209/0	STAFFA LEVA	CLAMP LEVER	BRIDE POUR LEVIER	BRIDE FÜR HEBEL	1
3	25774211/1	STAFFA MOLLA	CLAMP SPRING	BRIDE POUR RESSORT	BRIDE FÜR FEDER	1
4	25430206/1	MOLLA	SPRING	RESSORT	FEDER	1
5	12674550/0	VITE	SCREW	VIS	SCHRAUBE	1
6	12154510/0	DADO	NUT	ECROU	MUTTER	1
7	12791213/0	VITE	SCREW	VIS	SCHRAUBE	1
8	22672151/0	RONDELLA	WASHER	RONDELLE	SCHEIBE	1
9	12155010/0	DADO	NUT	ECROU	MUTTER	1
10	82394503/0	ASSIEME MANOPOLA	HANDLE ASS.Y	ENSEMBLE POIGNÉE	GRIFF	1
11	82004601/0	ASSIEME FILO (TC(P) 102)	WIRE ASS.Y (TC(P) 102)	ENSEMBLE FIL (TC(P) 102)	KABEL (TC(P) 102)	1
	82004602/0	ASSIEME FILO (TC(P) 122)	WIRE ASS.Y (TC(P) 122)	ENSEMBLE FIL (TC(P) 122)	KABEL (TC(P) 122)	1
12	25207100/0	FILO	WIRE	FIL	KABEL	1
13	25265000/0	GUAINA	SHEATH	GAINÉ	KABEL MANTEL	1
14	25646000/0	REGISTRO	ADJUSTER	REGISTRE	ZUGREGLER	1
15	13120101/0	BUSSOLA	BUSHING	DOUILLE	BÜCHSE	1
16	15407030/0	FASCETTA	CLIP	COLLIER	KABEL BAND	1
17	25430211/0	MOLLA (TC(P) 102)	SPRING (TC(P) 102)	RESSORT (TC(P) 102)	FEDER (TC(P) 102)	1
	25430221/0	MOLLA (TC(P) 122)	SPRING (TC(P) 122)	RESSORT (TC(P) 122)	FEDER (TC(P) 122)	1
18	22061337/0	CAVALLOTTO	CONNECTING PLATE	PLAQUE DE CONNEXION	BUGEL BOLZEN	1
19	12292100/0	DADO	NUT	ECROU	MUTTER	2
20	12523040/0	RONDELLA	WASHER	RONDELLE	SCHEIBE	1
21	12523060/0	RONDELLA	WASHER	RONDELLE	SCHEIBE	1
31	82547003/1	PIASTRA (TC(P) 102)	PLATE (TC(P) 102)	PLATE (TC(P) 102)	PLATTE (TC(P) 102)	1
	82547005/0	PIASTRA (TC(P) 122)	PLATE (TC(P) 122)	PLATE (TC(P) 122)	PLATTE (TC(P) 122)	1

Pos. Nr.	Codice Kodex Code	Descrizione	Description	Description	Beschreibung	Q.tà Q.ty Q.té Menge
32	12792611/0	VITE	SCREW	VIS	SCHRAUBE	4
33	12293201/0	DADO	NUT	ECROU	MUTTER	4
34	82785084/1	ASS. SUPPORTO	SUPPORT ASS.Y	ENS. SUPPORT	HALTERSATZ	1
35	25601559/1	PULEGGIA (TC(P) 102)	PULLEY (TC(P) 102)	POULIE (TC(P) 102)	RIEMENSCHLEIBE (TC(P) 102)	2
	25601561/1	PULEGGIA (TC(P) 122)	PULLEY (TC(P) 122)	POULIE (TC(P) 122)	RIEMENSCHLEIBE (TC(P) 122)	2
36	19216033/1	CUSCINETTO	BEARING	ROULEMENT	KUEGELLAGER	2
37	12610800/0	SEEGER	SEEGER	SEEGER	SEEGER	2
38	12609200/0	SEEGER	SEEGER	SEEGER	SEEGER	2
39	25650037/0	RINF. PULEGGE	PULLEY STIFFENING	REINFORCEMENT DES	RIEMENSCHLEIBE	
				POULIE	VERSTAERKUNG	1
40	12793102/0	VITE	SCREW	VIS	SCHRAUBE	2
41	12521350/0	RONDELLA	WASHER	RONDELLE	SCHLEIBE	2
42	12583500/0	GROWER	GROWER	GROWER	GROWER	2
43	25160003/0	DISTANZIALE	SPACER	ENTRETOISE	DISTANZRING	4
44	25038000/0	BOCCOLA	BUSHING	DOUILLE	BUCHSE	4
45	12691700/0	VITE	SCREW	VIS	SCHRAUBE	1
46	12691200/0	VITE	SCREW	VIS	SCHRAUBE	3
47	12521350/0	RONDELLA	WASHER	RONDELLE	SCHLEIBE	5
48	12155000/0	DADO	NUT	ECROU	MUTTER	4
49	12793900/0	VITE	SCREW	VIS	SCHRAUBE	1
50	12293200/0	DADO	NUT	ECROU	MUTTER	1
51	25601560/0	PULEGGIA (TC(P) 102)	PULLEY (TC(P) 102)	POULIE (TC(P) 102)	RIEMENSCHLEIBE (TC(P) 102)	2
	25601562/0	PULEGGIA (TC(P) 122)	PULLEY (TC(P) 122)	POULIE (TC(P) 122)	RIEMENSCHLEIBE (TC(P) 122)	2
52	12139480/0	CHIAVETTA	KEY	CLAVETTE	KEIL	3
53	12793102/0	VITE	SCREW	VIS	SCHRAUBE	1
54	25670007/0	RONDELLA	WASHER	RONDELLE	SCHLEIBE	1
55	12583500/0	GROWER	GROWER	GROWER	GROWER	1
56	35065600/0	CINGHIA (TC(P) 102)	BELT (TC(P) 102)	COURROIE (TC(P) 102)	KEILRIEMEN (TC(P) 102)	1
	35065601/0	CINGHIA (TC(P) 122)	BELT (TC(P) 122)	COURROIE (TC(P) 122)	KEILRIEMEN (TC(P) 122)	1
57	12815200/0	VITE	SCREW	VIS	SCHRAUBE	3
58	12292102/0	DADO	NUT	ECROU	MUTTER	3
59	25060100/1	CARTER (TC(P) 102)	CASE (TC(P) 102)	CARTER (TC(P) 102)	BLECH (TC(P) 102)	1
	25060101/0	CARTER (TC(P) 122)	CASE (TC(P) 122)	CARTER (TC(P) 122)	BLECH (TC(P) 122)	1
60	12735110/0	VITE	SCREW	VIS	SCHRAUBE	6
62	25601550/0	PULEGGIA (TC(P) 102)	PULLEY (TC(P) 102)	POULIE (TC(P) 102)	RIEMENSCHLEIBE (TC(P) 102)	1
	25601549/0	PULEGGIA (TC(P) 122)	PULLEY (TC(P) 122)	POULIE (TC(P) 122)	RIEMENSCHLEIBE (TC(P) 122)	1
63	12793102/0	VITE	SCREW	VIS	SCHRAUBE	1
64	25670007/0	RONDELLA	WASHER	RONDELLE	SCHLEIBE	1
65	12583500/0	GROWER	GROWER	GROWER	GROWER	1
66	25160002/0	DISTANZIALE	SPACER	ENTRETOISE	DISTANZRING	1
67	25318115/0	LEVA FRENO (TC(P) 102)	BRAKE LEVER (TC(P) 102)	LEVIER FREIN (TC(P) 102)	BREMSEBEL (TC(P) 102)	1
	25318119/0	LEVA FRENO (TC(P) 122)	BRAKE LEVER (TC(P) 122)	LEVIER FREIN (TC(P) 122)	BREMSEBEL (TC(P) 122)	1
68	25207000/1	FERODO	LINING	PASTILLE FREIN	BREMSEBELAG	1
69	12771400/0	VITE	SCREW	VIS	SCHRAUBE	2
70	12154330/0	DADO	NUT	ECROU	MUTTER	2
71	25601555/0	PULEGGIA	PULLEY	POULIE	RIEMENSCHLEIBE	1
72	25160007/0	DISTANZIALE	SPACER	ENTRETOISE	DISTANZRING	1
73	12818900/0	VITE	SCREW	VIS	SCHRAUBE	1
74	12523060/0	RONDELLA	WASHER	RONDELLE	SCHLEIBE	1
75	12155000/0	DADO	NUT	ECROU	MUTTER	1
76	12793101/0	VITE	SCREW	VIS	SCHRAUBE	1
77	12523070/0	RONDELLA	WASHER	RONDELLE	SCHLEIBE	1
78	12583500/0	GROWER	GROWER	GROWER	GROWER	1
79	25430210/0	MOLLA FRENO LAMA (TC(P) 102)	BLADE BRAKE SPRING (TC(P) 102)	RESSORT FREIN LAME (TC(P) 102)	MESSER BREMSE FEDER1 (TC(P) 102)	1
	25430220/0	MOLLA FRENO LAMA (TC(P) 122)	BLADE BRAKE SPRING (TC(P) 122)	RESSORT FREIN LAME (TC(P) 122)	MESSER BREMSE FEDER1 (TC(P) 122)	1
80	35062811/0	CINGHIA (TC(P) 102)	BELT (TC(P) 102)	COURROIE (TC(P) 102)	KEIL RIEMEN (TC(P) 102)	1
	35062812/0	CINGHIA (TC(P) 122)	BELT (TC(P) 122)	COURROIE (TC(P) 122)	KEIL RIEMEN (TC(P) 122)	1

GRUPPO PIATTO DI TAGLIO (2)
 CUTTING PLATE GROUP (2)
 GROUPE PLATEAU DE COUPE (2)
 SCHNEIDWERKZEUG (2)

Mod. 1996 **009**

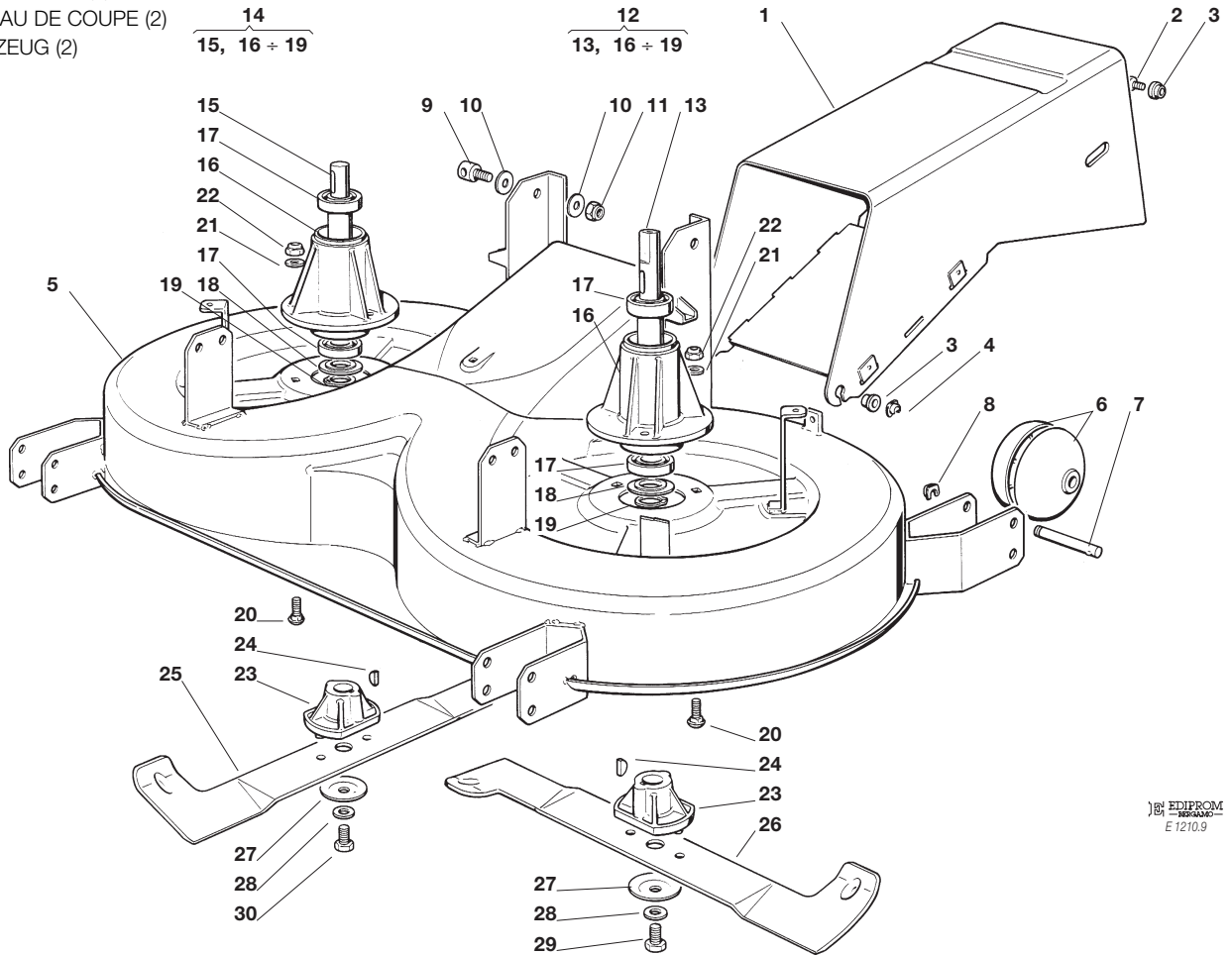

EDIPROM
 E 1210.9

Pos. Nr.	Codice Kodex Code	Descrizione	Description	Description	Beschreibung	Q.tà Q.ty Q.té Menge
1	82108004/0	ASSIEME CONVOGLIATORE POST.	REAR CONVEYOR ASS.Y	ENS. CONVOYEUR POST.	HINTERLEITBLECHSATZ	1
2	12793101/0	VITE	SCREW	VIS	SCHRAUBE	2
3	25038002/0	BOCCOLA	BUSHING	DOUILLE	BUCHSE	4
4	12436050/0	PIASTRINA	PLATE	PLAQUE	PLATTE	2
5	82564001/2	ASSIEME PIATTO DI TAGLIO (TC(P) 102)	CUTTING PLATE ASS.Y (TC(P) 102)	ENS. PLATEAU DE COUPE (TC(P) 102)	SCHNEIDWERKZEUG (TC(P) 102)	1
	82564005/0	ASSIEME PIATTO DI TAGLIO (TC(P) 122)	CUTTING PLATE ASS.Y (TC(P) 122)	ENS. PLATEAU DE COUPE (TC(P) 122)	SCHNEIDWERKZEUG (TC(P) 122)	1
6	82700000/0	RUOTINO ANTISCALPO	LEVELLING SMALL WHEEL	PETITE ROUEDE INVELLEMENT	EBENUNGRAEDCHEN	4
7	25510006/0	PERNO	PIN	PIVOT	BOLZEN	4
8	12436030/0	PIASTRINA	PLATE	PLAQUE	PLATTE	4
9	25510024/0	PERNO	PIN	PIVOT	BOLZEN	4
10	25670008/0	RONDELLA	WASHER	RONDELLE	SCHEIBE	8
11	12156602/0	DADO	NUT	ECROU	MUTTER	4
12	82207200/0	ASS. FLANGIA ALBERO PRINCIPALE (13, 16÷19)	BLADE MAIN SHAFT SUPPORT (13, 16÷19)	SUPPORT ARBRE LAME PRINCIPAL (13, 16÷19)	MASSERWELLEHAFTSATZ (13, 16÷19)	1
13	25020800/0	ALBERO LAMA PRINCIPALE	MAIN BLADE SHAFT	ARBRE LAME PRINCIPAL	HAUP MESSERWELLE	1
14	82207201/1	ASS. FLANGIA ALBERO SECONDARIO (15,16÷19)	BLADE SECONDARY SHAFT SUPPORT (15, 16÷19)	SUPPORT ARBRE LAME SECONDAIRE (15,16÷19)	MASSERWELLE ZWEITER-SATZ (15,16÷19)	1
15	25020801/1	ALBERO LAMA SECONDARIO	SECONDARY BLADE SHAFT	ARBRE LAME SECONDAIRE	ZWEITE MESSERWELLE	1
16	25207200/0	FLANGIA ALBERO LAMA	BLADE SHAFT SUPPORT	SUPPORT ARBRE LAME	MESSERWELLE	2
17	19216032/0	CUSCINETTO	BEARING	ROULEMENT	KUEGELLAGER	4
18	25160501/0	DISCO PARAPOLVERE	DUST COVER	PROTEGE-POUSSIERE	STAUBSCHUTTSCHIEBE	2
19	12609260/0	SEEGER	SEEGER	SEEGER	SEEGER	2

Pos. Nr.	Codice Kodex Code	Descrizione	Description	Description	Beschreibung	Q.tà Q.ty Q.té Menge
20	12818700/0	VITE	SCREW	VIS	SCHRAUBE	6
21	12521350/0	RONDELLA	WASHER	RONDELLE	SCHEIBE	6
22	12155000/0	DADO	NUT	ECROU	MUTTER	6
23	25463200/0	MOZZO COLTELLO	BLADE HUB	MOYEU LAME	MESSERHALTER	2
24	12139100/0	LINGUETTA	KEY	CLAVETTE	KEIL	2
25	82004341/0	ASS. COLTELLO DX (TC(P) 102)	RIGHT BLADE ASS.Y (TC(P) 102)	ENS. LAME DROITE (TC(P) 102)	RECHTER MESSERSATZ (TC(P) 102)	1
	82004343/0	ASS. COLTELLO DX (TC(P) 122)	RIGHT BLADE ASS.Y (TC(P) 122)	ENS. LAME DROITE (TC(P) 122)	RECHTER MESSERSATZ (TC(P) 122)	1
26	82004340/0	ASS. COLTELLO SX (TC(P) 102)	LEFT BLADE ASS.Y (TC(P) 102)	ENS. LAME GAUCHE (TC(P) 102)	LINKER MESSERSATZ (TC(P) 102)	1
	82004342/0	ASS. COLTELLO SX (TC(P) 122)	LEFT BLADE ASS.Y (TC(P) 122)	ENS. LAME GAUCHE (TC(P) 122)	LINKER MESSERSATZ (TC(P) 122)	1
27	22160400/0	DISCO ELASTICO	ELASTIC WASHER	RONDELLE ELASTIQUE	FEDERSCHEIBE	2
28	12523080/0	RONDELLA	WASHER	RONDELLE	SCHEIBE	2
29	12735694/0	VITE	SCREW	VIS	SCHRAUBE	1
30	12735695/0	VITE	SCREW	VIS	SCHRAUBE	1
—	82565000/0	PIATTO DI TAGLIO ASSEMBLATO (TC(P) 102) (008, 31÷80 + 009, 5÷30)	CUTTING PLATE, ASSEMBLED (TC(P) 102) (008, 31÷80 + 009, 5÷30)	PLATEAU DE COUPE,S COMPLETE (TC(P) 102) (008, 31÷80 + 009, 5÷30)	CHNEIDWERKZEUG, KOMPLETT (TC(P) 102) (008, 31÷80 + 009, 5÷30)	1
—	82565003/0	PIATTO DI TAGLIO, ASSEMBLATO (TC(P) 122) (008, 31÷80 + 009, 5÷30)	CUTTING PLATE, ASSEMBLED (TC(P) 122) (008, 31÷80 + 009, 5÷30)	PLATEAU DE COUPE,S COMPLETE (TC(P) 122) (008, 31÷80 + 009, 5÷30)	CHNEIDWERKZEUG, KOMPLETT (TC(P) 122) (008, 31÷80 + 009, 5÷30)	1

GRUPPO PIATTO DI TAGLIO (3)
 CUTTING PLATE GROUP (3)
 GROUPE PLATEAU DE COUPE (3)
 SCHNEIDWERKZEUG (3)

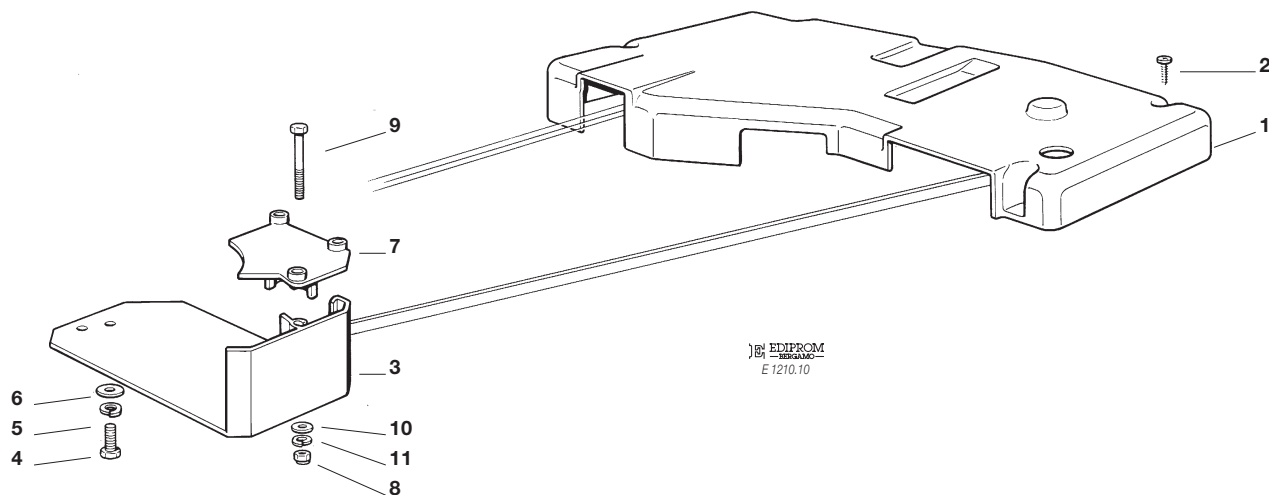

Pos. Nr.	Codice Kodex Code	Descrizione	Description	Description	Beschreibung	Q.tà Q.ty Q.té Menge
1	25600000/0	PROTEZIONE CINGHIA POST. (TC(P) 102)	REAR BELT PROTECTION (TC(P) 102)	PROTECTION COURROIRE POSTERIEURE (TC(P) 102)	HINTERR RIEMENSCHUTZ (TC(P) 102)	1
	25600008/0	PROTEZIONE CINGHIA POST. (TC(P) 122)	REAR BELT PROTECTION (TC(P) 122)	PROTECTION COURROIRE POSTERIEURE (TC(P) 122)	HINTERR RIEMENSCHUTZ (TC(P) 122)	1
2	12735402/0	VITE	SCREW	VIS	SCHRAUBE	4
3	25600005/0	PROTEZIONE INFERIORE	LOW PROTECTION	PROTECTION INFERIEURE	UNTERSCHUTZ FÜR VORDERRIEMEN	1
4	12789195/0	VITE	SCREW	VIS	SCHRAUBE	2
5	12581500/0	GROWER	GROWER	GROWER	GROWER	2
6	12523020/0	RONDELLA	WASHER	RONDELLE	SCHEIBE	2
7	25600006/0	PROTEZIONE SUPERIORE	UPPER PROTECTION	PROTECTION SUPERIEURE	OBERSCHUTZ FÜR VORDERRIEMEN	1
8	12154330/0	DADO	NUT	ECROU	MUTTER	3
9	12789360/0	VITE	SCREW	VIS	SCHRAUBE	3
10	12523020/0	RONDELLA	WASHER	RONDELLE	SCHEIBE	3

GRUPPO SOLLEVAMENTO SACCO E MICRO SACCO PIENO
 LIFTING DEVICE AND EMPTY GRASSCATCHER MICRO
 GROUPE SOULEVEMENT BAC ET MICRO BAC PLEIN
 AUSHEBENVORRICHTUNG UND VOLLKORBEIN RICHTUNG FÜR SACK

Mod. 1996

011

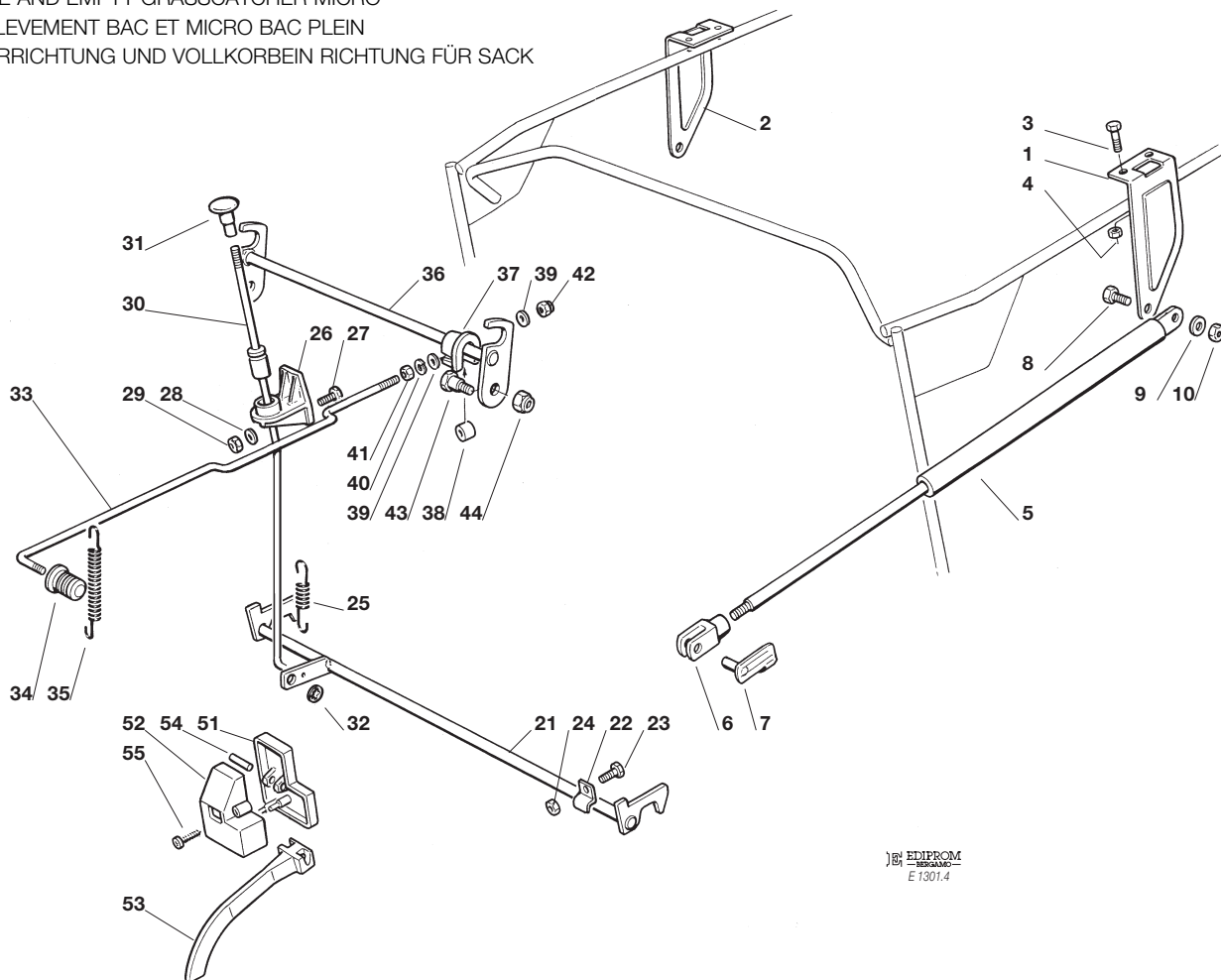

Pos. Nr.	Codice Kodex Code	Descrizione	Description	Description	Beschreibung	Q.tà Q.ty Q.té Menge
1	25547005/0	PIASTRA SX	LEFT PLATE	PLAQUE GAUCHE	LINKE PLATTE	1
2	25547007/0	PIASTRA DX	RIGHT PLATE	PLAQUE DROITE	RECHTE PLATTE	1
3	12792611/0	VITE	SCREW	VIS	SCHRAUBE	4
4	12293201/0	DADO	NUT	ECROU	MUTTER	4
5	18564600/0	PISTONE SOLLEVAMENTO	LIFTING PISTON	RESSORT A GAZ	GASFEDER	2
6	18399000/0	FORCELLA	FORK	FOURCHE	GABEL	2
7	18210200/0	CLIP	CLIP	CLIP	SPERRBOLZEN	2
8	12793101/0	VITE	SCREW	VIS	SCHRAUBE	2
9	12521350/0	ROSETTA	WASHER	RONDELLE	SCHEIBE	2
10	12155000/0	DADO	NUT	ECROU	MUTTER	2
21	82000353/0	ASTA AGGANCIO SACCO INF.	LOWER COUPLING ROD	TIGE D'ACCROCHAGE INF.	UTTERE KUPPLUNGSTANGE	1
22	25774220/0	STAFFA ANCORAGGIO	ANCHOR BRACKET	ETRIER	BRIDE	2
23	12791200/0	VITE	SCREW	VIS	SCHRAUBE	4
24	12292102/0	DADO	NUT	ECROU	MUTTER	2
25	25430213/0	MOLLA	SPRING	RESSORT	FEDER	1
26	25785055/0	SUPPORTO GUIDA ASTA	SUPPORT	SUPPORT	SUPPORT	1
27	12791200/0	VITE	SCREW	VIS	SCHRAUBE	1
28	12521330/0	ROSETTA	WASHER	RONDELLE	SCHEIBE	1
29	12154510/0	DADO	NUT	ECROU	MUTTER	1
30	82000454/0	ASTA SGANCIO	RELEASE ROD	TIGE DE DECCROCHAGE	ENTKUPPLUNGSTANGE	1
31	82394504/0	MANOPOLA	HANDLE	POIGNEE	GRIF	1
32	12604897/0	RONDELLA DI RITEGNO	WASHER	RONDELLE	SCHEIBE	1
33	25033010/0	ASTA BLOCCAGGIO	LOCKING ROD	TIGE DE BLOCAGE	KLEMENSTANGE	1
34	82394505/0	MANOPOLA	HANDLE	POINGEE	GRIF	1

Pos. Nr.	Codice Kodex Code	Descrizione	Description	Description	Beschreibung	Q.tà Q.ty Q.té Menge
35	25430208/0	MOLLA	SPRING	RESSORT	FEDER	1
36	82000351/0	ASTA AGGANCIO SACCO SUP.	UPPER COUPLING ROD	TIGE D'ACCROCHAGE SUP.	OBERE KUPLUNGSTANGE	1
37	25774218/0	STAFFA ANCORAGGIO ASTA	BRACKET	ENTRETIER	BRIDE	1
38	25160012/0	DISTANZIALE	SPACER	ENTRETOISE	ENTFERNUNGGSTUECK	1
39	12531330/0	ROSETTA	WASHER	RONDELLE	SCHEIBE	2
40	12582101/0	GROWER	GROWER	GROWER	GROWER	1
41	12292100/0	DADO	NUT	ECROU	MUTTER	1
42	12154510/0	DADO	NUT	ECROU	MUTTER	1
43	25510025/0	PERNO	PIN	PIVOT	BOLZEN	2
44	12156602/0	DADO	NUT	ECROU	MUTTER	2
51	25600014/0	COPERCHIO PROTEZIONE	PROTECTION	PROTECTION	SHUTZ	1
52	25600013/0	PROTEZIONE MICRO	MICRO PROTECTION	PROTECTION MICRO	SCHUTZ	1
53	25318122/0	LEVA	LEVER	LEVIER	HEBEL	1
54	12400030/0	PERNO	PIN	PIVOT	BOLZEN	1
55	12728440/0	VITE	SCREW	VIS	SCHRAUBE	2

GRUPPO PARTI ELETTRICHE
 ELECTRICAL PARTS GROUP
 GROUPE PARTIES ELECTRIQUES
 ELETRISCHETEILE

Mod. 1996

012

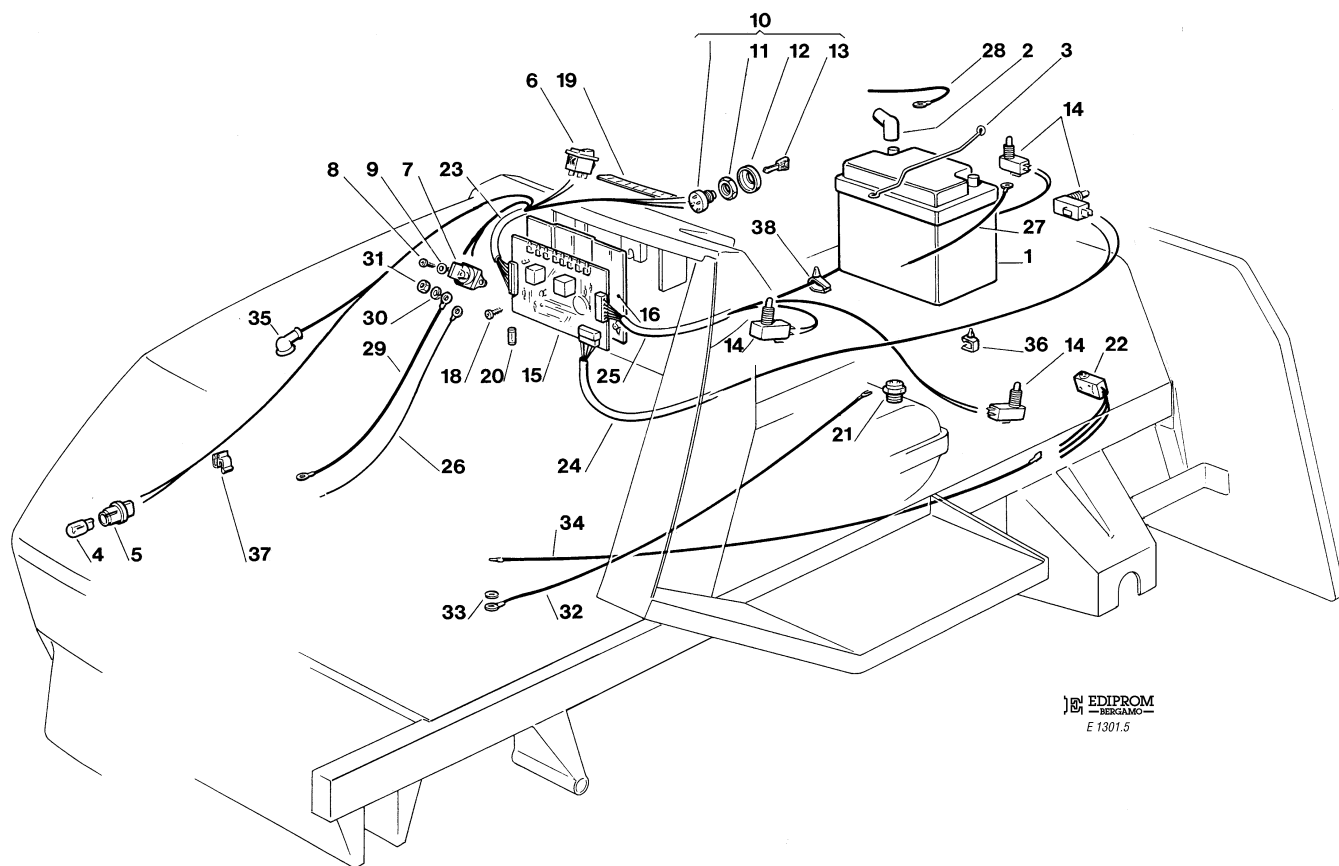

EDIPROM
 E 1301.5

Pos. Nr.	Codice Kodex Code	Descrizione	Description	Description	Beschreibung	Q.tà Q.ty Q.té Menge
1	18120000/0	BATTERIA 12 V - 20 Ah	BATTERY 12 V - 20 Ah	BATTERIE 12 V - 20 Ah	BATTERIE 12 V - 20 Ah	1
	18120001/0	BATTERIA 12 V - 24 Ah	BATTERY 12 V - 24 Ah	BATTERIE 12 V - 24 Ah	BATTERIE 12 V - 24 Ah	1
2	25600001/0	PROTEZIONE	PROTECTION	PROTECTION	SCHUTZ	1
3	25430200/0	MOLLA	SPRING	RESSORT	FEDER	2
4	18459100/0	LAMPADA	FARILAMP FOR LIGHTS	LAMPE POUR PHARES	LAMPENFASSUN	2
5	33500030/0	PORTALAMPADE	LAMP HOLDER	DOUILLE DE LAMPE	SCHENWERFERLAMPE	2
6	18450060/0	INTERRUTTORE	FARILAMP SWITCH	INTERRUPTEUR PHARES	LICHTEN SCHALTER	1
7	18736110/0	SOLENOIDE	SOLENOID	SOLENOIDE	SOLENOID	1
8	12728510/0	VITE	SCREW	VIS	SCHRAUBE	2
9	12521320/0	RONDELLA	WASHER	RONDELLE	SCHEIBE	2
10	18450065/1	INTERRUTTORE AVVIAMENTO	STARTING SWITCH	INTERRUPTEUR DEMARRAGE	SCHALTER	1
11	18400861/0	GHIERA	SCREWED RING	EMBOUIT	NUTMUTTER	1
12	18565351/0	PROTEZIONE GHIERA	SCREWED RING PROTECTION	PROTECTION EMBOUT	NUTMUTTER SCHUTZ	1
13	18210016/0	CHIAVE AVVIAMENTO	STARTING KEY	CLEF A DEMARRAGE	SCHLÜSSEL FÜR START	1
14	19410603/1	MICRO INTERRUTTORE	MICRO	MICRO	MIKRO	4
15	***	SCHEDA ELETTRONICA	ELECTRONIC CARD	CARTE ELECTRONIQUE	ELEKTRONISCHE KARTE	1
16	25600007/0	PROTEZIONE SCHEDA (TC)	CARD PROTECTION (TC)	PROTECTION CARTE (TC)	KARTESCHUTZ (TC)	1
16	25600009/0	PROTEZIONE SCHEDA (TCP)	CARD PROTECTION (TCP)	PROTECTION CARTE (TCP)	KARTESCHUTZ (TCP)	1
18	12735105/0	VITE	SCREW	VIS	SCHRAUBE	3
19	25420000/0	MEMBRANA (6 FUNZ.)	CHECK CONTROLL (6 FUNCTIONS)	PANNEAU DE CONTROLE (6 INDICATIONS)	KONTROLLTAFEL (6 ANGABEN)	1
	25420001/0	MEMBRANA (8 FUNZ.)	CHECK CONTROLL (8 FUNCTIONS)	PANNEAU DE CONTROLE (8 INDICATIONS)	KONTROLLTAFEL (8 ANGABEN)	1
20	33340033/0	FUSIBILE 6,3 Amp. T	FUSE 6.3 Amp. T	FUSIBLE 6,3 Amp. T	SICHERUNG 6,3 Amp. T	1
21	19410604/0	INTERRUTTORE CAMBIO	GEARBOX SWITCH	INT. BOÎTE DE VITESSE	ANTRIEB SCHALTER	1

Pos. Nr.	Codice Kodex Code	Descrizione	Description	Description	Beschreibung	Q.tà Q.ty Q.té Menge
22	25425000/0	MICRO SACCO PIENO	FULL GRASSCATCHER MICROSWITCH	MICRO BAC PLEIN	VOLLKORB VORRICHTUNG	1
23	☛	ASS. CABLAGGIO	CABLES ASS.Y	ENS. CABLAGES	KABELSATZ	1
	82040024/0	12,5 HP B&S	12,5 HP B&S	12,5 HP B&S	12,5 HP B&S	
	82040026/0	16 HP B&S	16 HP B&S	16 HP B&S	16 HP B&S	
	82040022/0	14 HP KOHLER	14 HP KOHLER	14 HP KOHLER	14 HP KOHLER	
	82040025/0	15,5HP B&S	15,5HP B&S	15,5HP B&S	15,5HP B&S	
	82040027/0	18 HP KOHLER	18 HP KOHLER	18 HP KOHLER	18 HP KOHLER	
24	☛	ASS. CABLAGGIO	CABLES ASS.Y	ENS. CABLAGES	KABELSATZ	1
	82040004/1	12,5 - 15,5 HP B&S - 14 - 18 HP KOHLER	12,5 - 15,5 HP B&S - 14 - 18 HP KOHLER	12,5 - 15,5 HP B&S - 14 - 18 HP KOHLER	12,5 - 15,5 HP B&S - 14 - 18 HP KOHLER	
	82040005/1	16 HP B&S	16 HP B&S	16 HP B&S	16 HP B&S	
25	***	ASS. CABLAGGIO	CABLES ASS.Y	ENS. CABLAGES	KABELSATZ	1
26	☛	CAVO RICARICA	CABLE	CABLES	KABEL	1
	25065003/0	12,5 - 15,5 - 16 HP B&S	12,5 - 15,5 - 16 HP B&S	12,5 - 15,5 - 16 HP B&S	12,5 - 15,5 - 16 HP B&S	
	25065008/0	18 HP KOHLER	18 HP KOHLER	18 HP KOHLER	18 HP KOHLER	
27	25065004/0	CAVO MASSA BATTERIA	CABLE	CABLES	KABEL	1
28	25065001/0	CAVO BATT. SOLENOIDE	CABLE	CABLES	KABEL	1
29	25065002/0	CAVO SOLENOIDE MOT.	CABLE	CABLES	KABEL	1
30	12583500/0	GROWER	GROWER	GROWER	GROWER	2
31	12360352/0	DADO	NUT	ECROU	MUTTER	2
32	25065005/0	CAVO MASSA	CABLE	CABLES	KABEL	1
33	12540260/0	RONDELLA	WASHER	RONDELLE	SCHEIBE	1
34	***	CAVO COLL. MICRO	CABLE	CABLES	KABEL	1
35	18564861/0	CAPPUCCIO PROTEZIONE	PROTECTION	PROTECTION	SCHUTZ	1
36	33320505/0	FERMACAVO	FAIRLED	FIXATION CABLE	KABELBEFESTIGUNG	1
37	33320504/0	FERMACAVO	FAIRLED	FIXATION CABLE	KABELBEFESTIGUNG	1
38	33320506/0	FERMACAVO	FAIRLED	FIXATION CABLE	KABELBEFESTIGUNG	2

***** PER I PARTICOLARI CONTRASSEGNA TI, VERIFICARE L'ALLESTIMENTO DEL TRATTO RINO:
FOR THE MARKED ITEMS, PLEASE CHECK TRACTOR'S VERSION:
POUR LES PIECES MARQUEES, VERIFIEZ LA VERSION DE L'AUTOPORTEE:
FÜR KENNENZEICHNETEN TEILE, BITTE PRÜFEN SIE DER AUFSITZMÄHERAUSSTATTUNG:**

a) Motore 12,5 - 15,5 HP B&S, 14 - 18 HP Kohler + Interruttore cambio (21)

Engine 12,5 - 15,5 HP B&S, 14 - 18 HP Kohler + Gearbox switch (21)

Moteur 12,5 - 15,5 HP B&S, 14 - 18 HP Kohler + Interrupteur boîte de vitesse (21)

Motor 12,5 - 15,5 HP B&S, 14 - 18 HP Kohler + Antrieb Schalter (21)

15	25722405/0	SCHEDA ELETTRONICA 6 FUNZIONI	ELECTRONIC CARD 6 FUNCTIONS	CARTE ELECTRONIQUE 6 INDICAT	ELEKTRONISCHE KARTE 6 ANGABEN	1
25	82040002/1	ASS. CABLAGGIO	CABLES ASS.Y	ENS. CABLAGES	KABELSATZ	1

b) Motore 12,5 - 15,5 HP B&S, 14 - 18 HP Kohler + Interruttore cambio (21) + Micro sacco pieno (22)

Engine 12,5 - 15,5 HP B&S, 14 - 18 HP Kohler + Gearbox switch (21) + Full grasscatcher micriswitch (22)

Moteur 12,5 - 15,5 HP B&S, 14 - 18 HP Kohler + Interrupteur boîte de vitesse (21) + Micro bac plein (22)

Motor 12,5 - 15,5 HP B&S, 14 - 18 HP Kohler + Antrieb Schalter (21) + Vollkorb Vorrichtung (22)

15	25722406/0	SCHEDA ELETTRONICA 6 FUNZIONI	ELECTRONIC CARD 6 FUNCTIONS	CARTE ELECTRONIQUE 6 INDICAT	ELEKTRONISCHE KARTE 6 ANGABEN	1
25	82040029/0	ASS. CABLAGGIO	CABLES ASS.Y	ENS. CABLAGES	KABELSATZ	1
34	25065011/0	CAVO COLL. MICRO	CABLE	CABLES	KABEL	1

c) Motore 16 HP B&S + Interruttore cambio (21) + Micro sacco pieno (22)

Engine 16 HP B&S + Gearbox switch (21) + Full grasscatcher micriswitch (22)

Moteur 16 HP B&S + Interrupteur boîte de vitesse (21) + Micro bac plein (22)

Motor 16 HP B&S + Antrieb Schalter (21) + Vollkorb Vorrichtung (22)

15	25722407/0	SCHEDA ELETTRONICA 8 FUNZIONI	ELECTRONIC CARD 8 FUNCTIONS	CARTE ELECTRONIQUE 8 INDICAT	ELEKTRONISCHE KARTE 8 ANGABEN	1
25	82040028/0	ASS. CABLAGGIO	CABLES ASS.Y	ENS. CABLAGES	KABELSATZ	1
34	25065011/0	CAVO COLL. MICRO	CABLE	CABLES	KABEL	1

GRUPPO SACCO
 GRASSCATCHER GROUP
 GROUPE SAC
 GRASFANGEINRICHTUNG

Mod. 1996

013

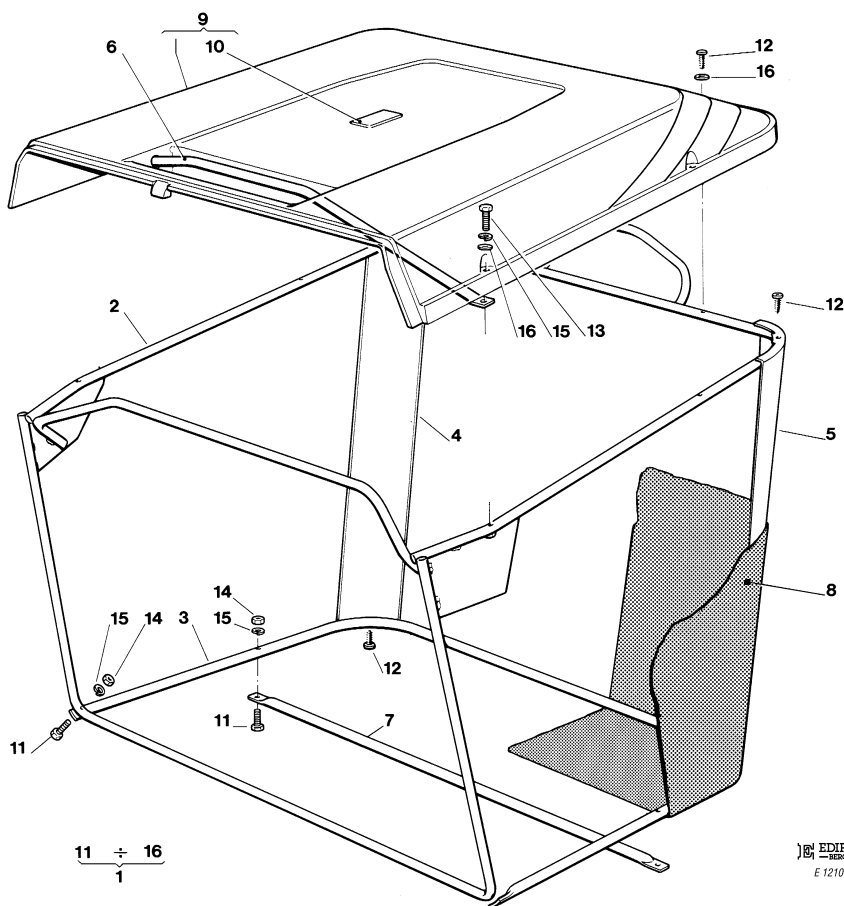

Pos. Nr.	Codice Kodex Code	Descrizione	Description	Description	Beschreibung	Q.tà Q.ty Q.té Menge
1	82180000/2	DOTAZIONE SACCO	GRASS-BOX OUTFIT	DOTATION BAC	KORBAUS TATTUNG	1
2	82800008/0	ASS. TELAIO SUP.	UPPER FRAME ASS.Y	ENS. CHASSIS SUPERIEUR	OBERERRAHMEN SATZ	1
3	82800002/0	ASS. TELAIO INF.	LOWER FRAME ASS.Y	ENS. CHASSIS INFERIEUR	UNTERERRAHMEN SATZ	1
4	25032001/1	ANGOLARE DX	RIGHT ANGULAR SUPPORT	SUPPORT ANGULAIRE DROITE	RECHTER HALTER	1
5	25032002/1	ANGOLARE SX	LEFT ANGULAR SUPPORT	SUPPORT ANGULAIRE GAUCHE	LINKER HALTER	1
6	82394001/0	MANIGLIA ANT.	FRONT HANDLE	POIGNEE ANTERIEURE	VORDERGRIFF	1
7	82650038/0	RINFORZO INF.	LOWER STIFFENING	RENFORCEMENT SUPER.	OBERE VERSTAERKUNG	1
8	82106000/1	SACCO	GRASSCATCHER	SAC	SACK	1
9	☛	COPERTURA SACCO (TC)	GRASSCAT. PLASTIC (TC)	SAC COUVERTURE (TC)	SACKABDECKUNG (TC)	1
	82110158/1	ROSSA	RED	ROUGE	ROT	
	82110159/0	VERDE	GREEN)	VERT	GRÜN	
	82110160/0	GIALLA	YELLOW	JAUNE	GELB	
	82110161/0	BLU	BLUE	BLEU	BLAU	
	☛	COPERTURA SACCO (TCP)	GRASSCAT. PLASTIC (TCP)	SAC COUVERTURE (TCP)	SACKABDECKUNG (TCP)	1
	82110170/0	ROSSA	RED	ROUGE	ROT	
	82110171/0	VERDE	GREEN)	VERT	GRÜN	
	82110172/0	GIALLA	YELLOW	JAUNE	GELB	
	82110173/0	BLU	BLUE	BLEU	BLAU	
10	☛	PIASTRINA (TC)	PLATE (TC)	PLAQUE (TC)	PLATTE (TC)	1
	25547016/1	ROSSA	RED	ROUGE	ROT	
	25547015/0	VERDE	GREEN	VERT	GRÜN	
	25547014/0	GIALLA	YELLOW	JAUNE	GELB	
	25547024/0	BLU	BLUE	BLEU	BLAU	

Pos. Nr.	Codice Kodex Code	Descrizione	Description	Description	Beschreibung	Q.tà Q.ty Q.té Menge
	☛ 25547025/0	PIASTRINA (TCP) ROSSA	PLATE (TCP) RED	PLAQUE (TCP) ROUGE	PLATTE (TCP) ROT	1
	25547026/0	VERDE	GREEN	VERT	GRÜN	
	25547027/0	GIALLA	YELLOW	JAUNE	GELB	
	25547028/0	BLU	BLUE	BLEU	BLAU	
11	12792099/0	VITE	SCREW	VIS	SCHRAUBE	4
12	12729601/0	VITE	SCREW	VIS	SCHRAUBE	8
13	12674701/0	VITE	SCREW	VIS	SCHRAUBE	2
14	12292100/0	DADO	NUT	ECROU	MUTTER	4
15	12582101/0	GROWER	GROWER	GROWER	GROWER	6
16	12521331/0	RONDELLA	WASHER	RONDELLE	SCHEIBE	6

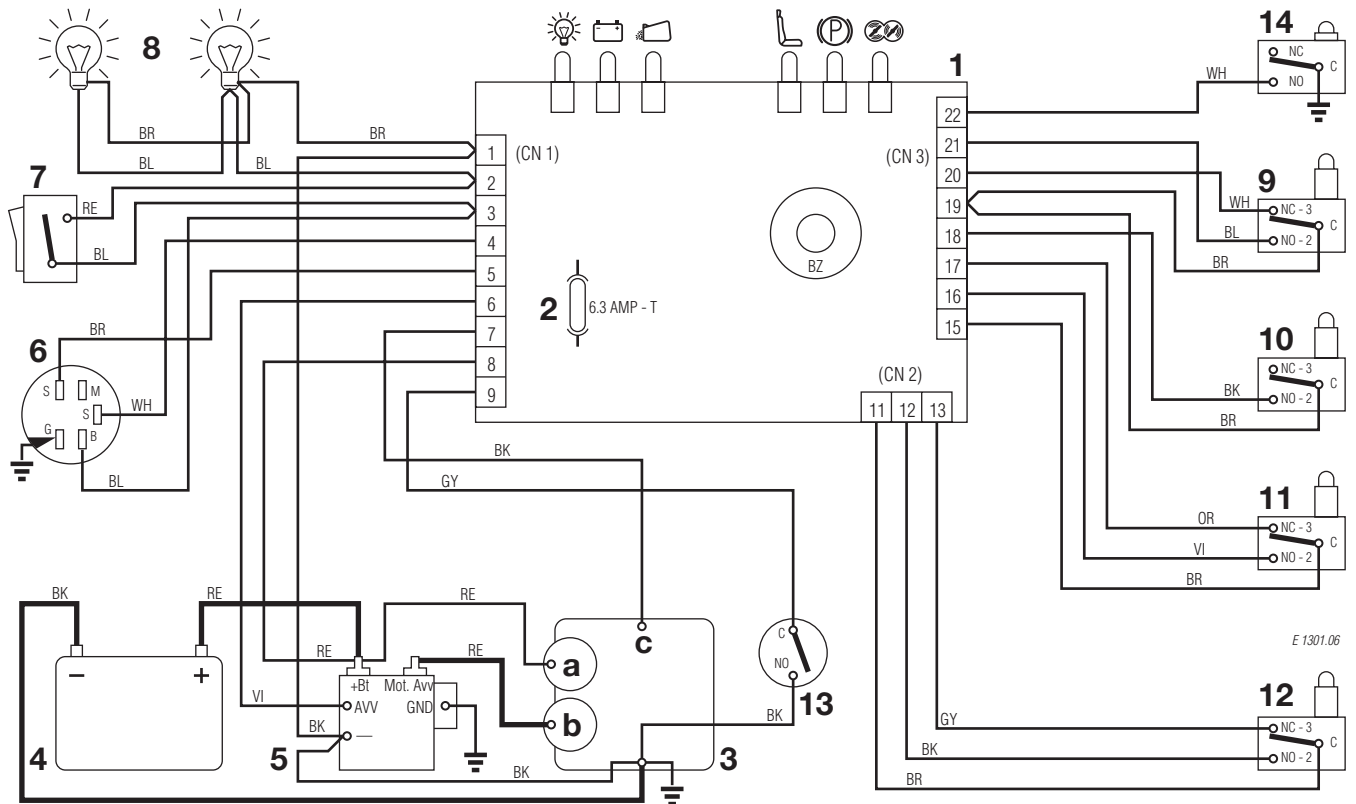

E 1301.06

1	SCHEDA CON BUZZER	ELECTRONIC CARD WITH BUZZER	CARTE ELECTRONIQUE AVEC BUZZER	ELECTRONISCHE KARTE MIT BUZZER
2	FUSIBILE 6,3 Amp. T	FUSE 6.3 Amp. T	FUSIBLE 6,3 Amp. T	SICHERUNG 6,3 Amp. T
3	MOTORE	ENGINE	MOTEUR	MOTOR
3a	Generatore	Generator	Generateur	Generator
3b	Motorino avviamento	Starter	Demarreur	Anlasser
3c	Stop motore	Engine stop	Calage du moteur	Motor abstellung
4	BATTERIA	BATTERY	BATTERIE	BATTERIE
5	RELE AVVIAMENTO	STARTER RELAY	RELAIS DE DEMARRAGE	ANLASSER RELAIS
6	INTERRUTTORE A CHIAVE	ELECTROLOCK	INTERRUPTEUR D'ALLUMAGE	SCHLÜSSELSCHALTER
7	INTERRUTTORE FARI	HEADLIGHT SWITCH	INTERRUPTEUR PHARES	LICHTSCHALTER
8	FARI	HEADLIGHT	PHARES	LICHT
9	MICROINTERRUTTORE LAME	BLADES MICRO SWITCH	MICRO INTERRUPTEUR LAMES	MESSER MIKROSCHALTER
10	MICROINTERRUTTORE FRENO	BRAKE MICRO SWITCH	MICRO INTERRUPTEUR FREIN	BREMSE MIKROSCHALTER
11	MICROINTERRUTTORE SEDILE	SEAT MICRO SWITCH	MICRO INTERRUPTEUR SIEGE	SITZMIKROSCHALTER
12	MICROINTERRUTTORE SACCO	GRASSCATCHER MICRO SWITCH	MICRO INTERRUPTEUR BAC	GRASFANGRICHTUNG MIKROSCHALTER
13	MICROINTERRUTTORE CAMBIO	GERARBOX MICROSWITCH	MICRO INT. BOÎTE DE VITESSE	ANTRIEB MICROSCHALTER
14	MICROINTERRUTTORE SACCO PIENO (dove previsto)	FULL GRASSCATCHER MICRO SWITCH (where fitted)	MICRO BAC PLEIN (si present)	VOLLKORB VORRICHTUNG (wenn vorgesehen)

COLORI CAVI

BK	NERO
BL	BLU
BR	MARRONE
GY	GRIGIO
OR	ARANCIONE
RE	ROSSO
VI	VIOLA
YG	GIALLO/VERDE
WH	BIANCO

CABLE COLOURS

BLACK
BLUE
BROWN
GREY
ORANGE
RED
VIOLET
YELLOW/GREEN
WHITE

COULEUR CABLES

NOIR
BLEU
BUN
GRIS
ORANGE
ROUGE
VIOLEY
JAUNE/VERT
BLANC

KABEL FARBEN

SCHWARZ
BLAU
BRAUN
GRAU
ORANGE
ROT
VIOLETT
GELB/GRÜN
WEISS

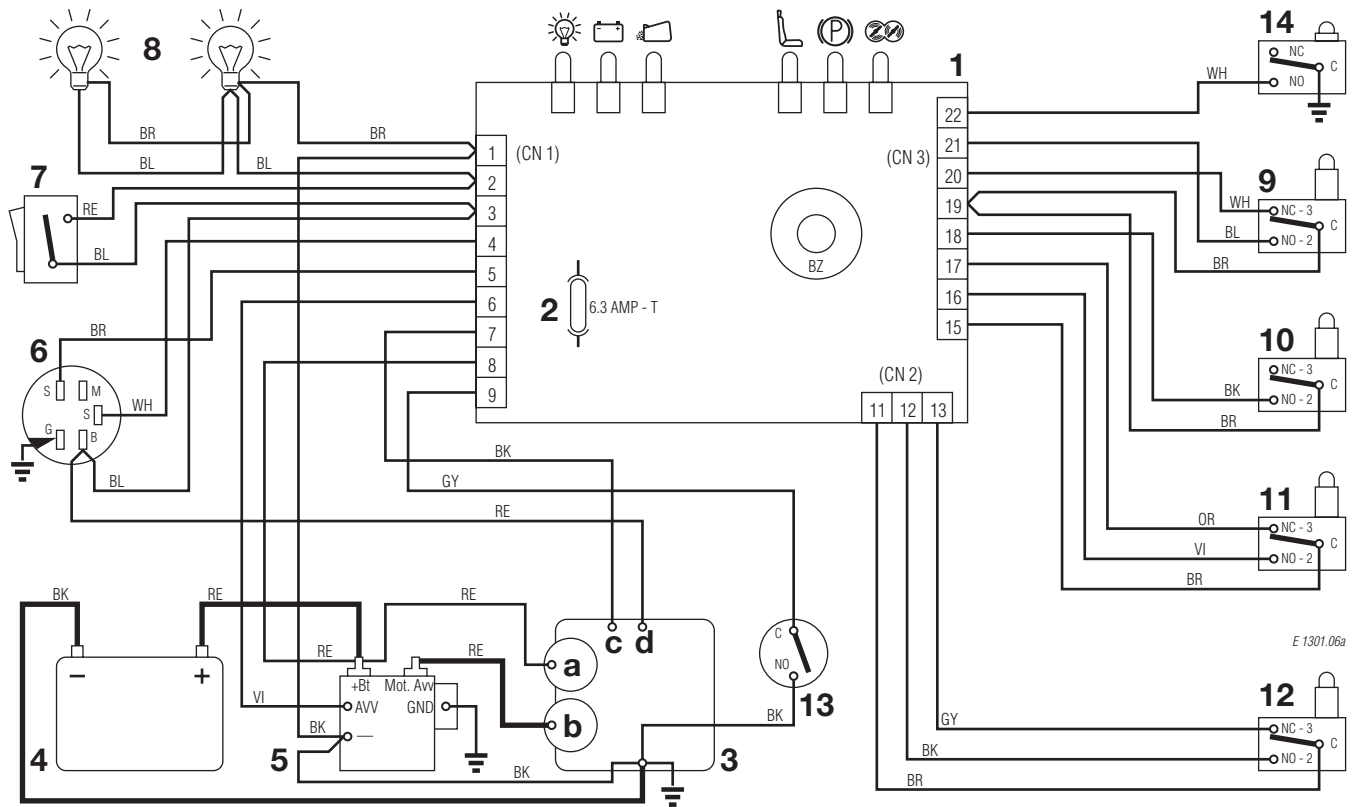

E 1301.06a

1	SCHEDA CON BUZZER	ELECTRONIC CARD WITH BUZZER	CARTE ELECTRONIQUE AVEC BUZZER	ELECTRONISCHE KARTE MIT BUZZER
2	FUSIBILE 6,3 Amp. T	FUSE 6.3 Amp. T	FUSIBLE 6,3 Amp. T	SICHERUNG 6,3 Amp. T
3	MOTORE	ENGINE	MOTEUR	MOTOR
3a	Generatore	Generator	Genérateur	Generator
3b	Motorino avviamento	Starter	Demarreur	Anlasser
3c	Stop motore	Engine stop	Calage du moteur	Motor abstellung
3d	Carburatore	Carburetor	Carburateur	Vergaser
4	BATTERIA	BATTERY	BATTERIE	BATTERIE
5	RELE AVVIAMENTO	STARTER RELAY	RELAIS DE DEMARRAGE	ANLASSER RELAIS
6	INTERRUTTORE A CHIAVE	ELECTROLOCK	INTERRUPTEUR D'ALLUMAGE	SCHLÜSSELSCHALTER
7	INTERRUTTORE FARI	HEADLIGHT SWITCH	INTERRUPTEUR PHARES	LICHTSCHALTER
8	FARI	HEADLIGHT	PHARES	LICHT
9	MICROINTERRUTTORE LAME	BLADES MICRO SWITCH	MICRO INTERRUPTEUR LAMES	MESSER MIKROSCHALTER
10	MICROINTERRUTTORE FRENO	BRAKE MICRO SWITCH	MICRO INTERRUPTEUR FREIN	BREMSE MIKROSCHALTER
11	MICROINTERRUTTORE SEDILE	SEAT MICRO SWITCH	MICRO INTERRUPTEUR SIEGE	SITZMIKROSCHALTER
12	MICROINTERRUTTORE SACCO	GRASSCATCHER MICRO SWITCH	MICRO INTERRUPTEUR BAC	GRASFANGEINRICHTUNG MIKROSCHALTER
13	MICROINTERRUTTORE CAMBIO	GERARBOX MICROSWITCH	MICRO INT. BOÎTE DE VITESSE	ANTRIEB MICROSWITCH
14	MICROINTERRUTTORE SACCO PIENO (dove previsto)	FULL GRASSCATCHER MICRO SWITCH (where fitted)	MICRO BAC PLEIN (si present)	VOLLKORB VORRICHTUNG (wenn vorgesehen)

COLORI CAVI	CABLE COLOURS	COULEUR CABLES	KABEL FARBEN
BK NERO	BLACK	NOIR	SCHWARZ
BL BLU	BLUE	BLEU	BLAU
BR MARRONE	BROWN	BUN	BRAUN
GY GRIGIO	GREY	GRIS	GRAU
OR ARANCIONE	ORANGE	ORANGE	ORANGE
RE ROSSO	RED	ROUGE	ROT
VI VIOLA	VIOLET	VIOLEY	VIOLETT
YG GIALLO/VERDE	YELLOW/GREEN	JAUNE/VERT	GELB/GRÜN
WH BIANCO	WHITE	BLANC	WEISS

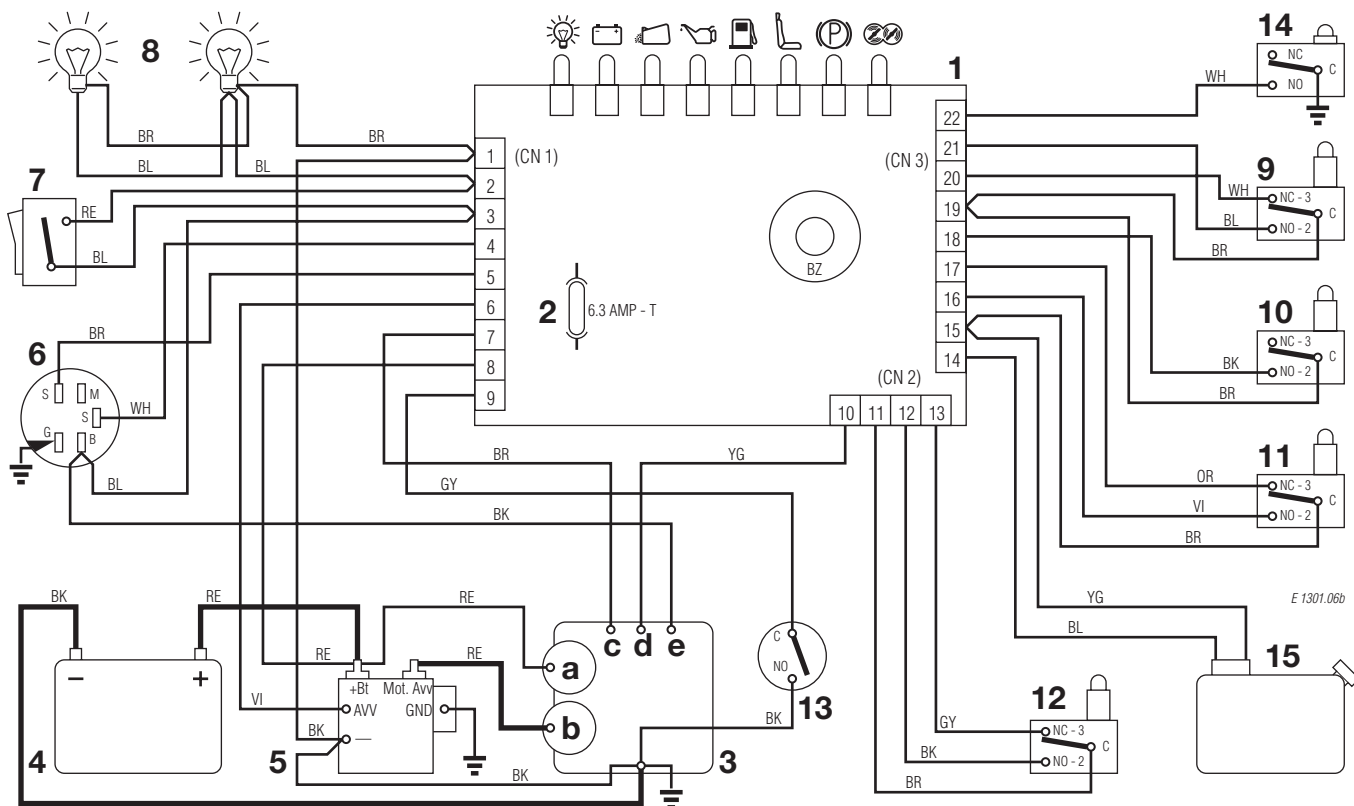

1	SCHEDA CON BUZZER	ELECTRONIC CARD WITH BUZZER	CARTE ELECTRONIQUE AVEC BUZZER	ELECTRONISCHE KARTE MIT BUZZER
2	FUSIBILE 6,3 Amp. T	FUSE 6.3 Amp. T	FUSIBLE 6,3 Amp. T	SICHERUNG 6,3 Amp. T
3	MOTORE	ENGINE	MOTEUR	MOTOR
3a	Generatore	Generator	Generateur	Generator
3b	Motorino avviamento	Starter	Demarreur	Anlasser
3c	Stop motore	Engine stop	Calage du moteur	Motor abstellung
3d	Olio	Oil	Huile	Öl
3e	Carburatore	Carburetor	Carburateur	Vergaser
4	BATTERIA	BATTERY	BATTERIE	BATTERIE
5	RELE AVVIAMENTO	STARTER RELAY	RELAIS DE DEMARRAGE	ANLASSER RELAIS
6	INTERRUTTORE A CHIAVE	ELECTROLOCK	INTERRUPTEUR D'ALLUMAGE	SCHLÜSSELSCHALTER
7	INTERRUTTORE FARI	HEADLIGHT SWITCH	INTERRUPTEUR PHARES	LICHTSCHALTER
8	FARI	HEADLIGHT	PHARES	LICHT
9	MICROINTERRUTTORE LAME	BLADES MICRO SWITCH	MICRO INTERRUPTEUR LAMES	MESSER MIKROSCHALTER
10	MICROINTERRUTTORE FRENO	BRAKE MICRO SWITCH	MICRO INTERRUPTEUR FREIN	BREMSE MIKROSCHALTER
11	MICROINTERRUTTORE SEDILE	SEAT MICRO SWITCH	MICRO INTERRUPTEUR SIEGE	SITZMIKROSCHALTER
12	MICROINTERRUTTORE SACCO	GRASSCATCHER MICRO SWITCH	MICRO INTERRUPTEUR BAC	GRASFANGEINRICHTUNG MIKROSCHALTER
13	MICROINTERRUTTORE CAMBIO	GERARBOX MICROSWITCH	MICRO INT. BOÎTE DE VITESSE	ANTRIEB MICROSCHALTER
14	MICROINTERRUTTORE SACCO PIENO (dove previsto)	FULL GRASSCATCHER MICRO SWITCH (where fitted)	MICRO BAC PLEIN (si present)	VOLLKORB VORRICHTUNG (wenn vorgesehen)
15	SERBATOIO	TANK	RESERVIOIR	TANK

COLORI CAVI

BK	NERO
BL	BLU
BR	MARRONE
GY	GRIGIO
OR	ARANCIONE
RE	ROSSO
VI	VIOLA
YG	GIALLO/VERDE
WH	BIANCO

CABLE COLOURS

BK	BLACK
BL	BLUE
BR	BROWN
GY	GREY
OR	ORANGE
RE	RED
VI	VIOLET
YG	YELLOW/GREEN
WH	WHITE

COULEUR CABLES

BK	NOIR
BL	BLEU
BR	BUN
GY	GRIS
OR	ORANGE
RE	ROUGE
VI	VIOLEY
YG	JAUNE/VERT
WH	BLANC

KABEL FARBEN

BK	SCHWARZ
BL	BLAU
BR	BRAUN
GY	GRAU
OR	ORANGE
RE	ROT
VI	VIOLETT
YG	GELB/GRÜN
WH	WEISS

ACCESSORI A RICHIESTA
 OPTIONALS ON REQUEST
 ACCESSOIRES SUR DEMANDE
 ZUBEHOERE NACH ANFRAGE

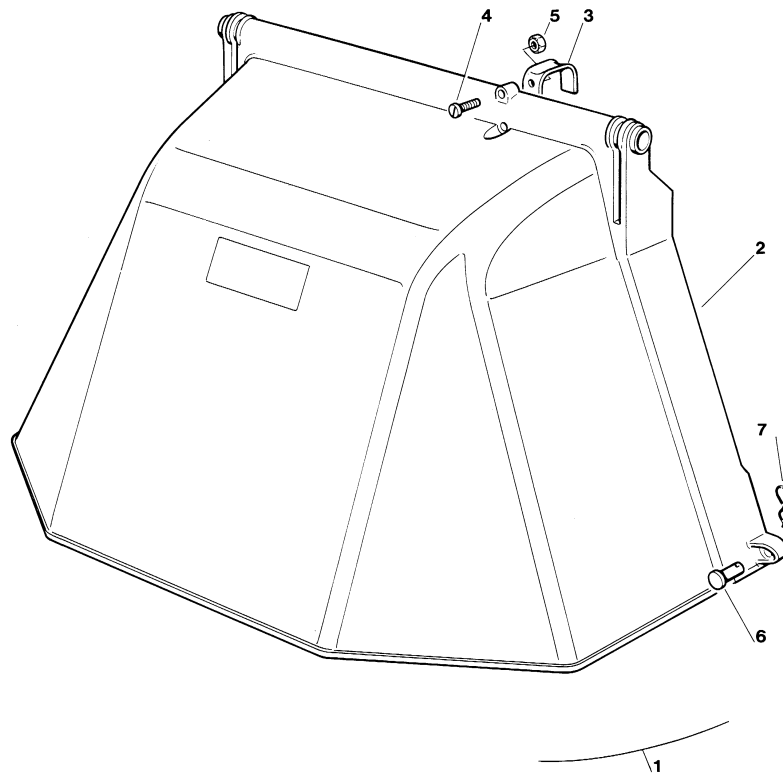
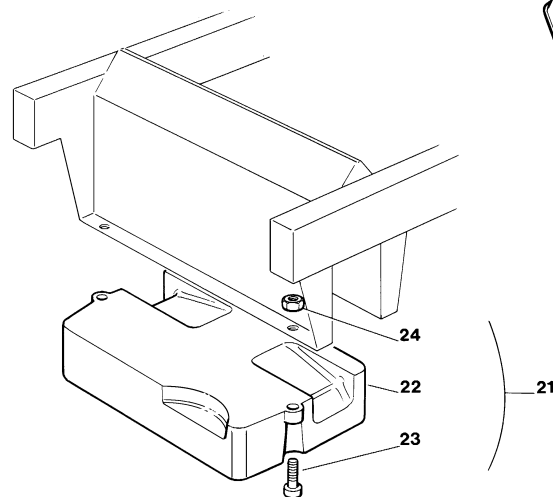
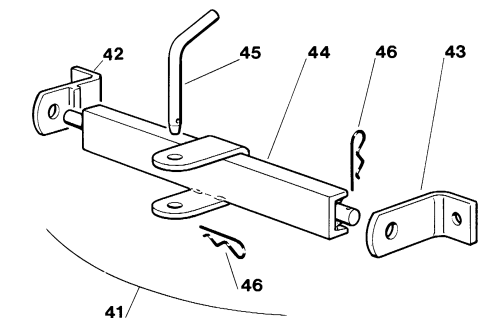

EDIPROM
 E 1210.14

Pos. Nr.	Codice Kodex Code	Descrizione	Description	Description	Beschreibung	Q.tà Q.ty Q.té Menge
1	99900010/0	ASS. KIT PROTEZIONE USCITA	EJECTION-GUARD ASS.Y	KIT PROTECTION SORTIE	VORRICHTUNG FÜR AUSWURESCHUTZ	1
2	82400001/1	PROTEZIONE USCITA	EJECTION GUARD	PROTECTION SORTIE	AUSWURFSCHUTZ	1
3	25430216/0	MOLLA	SPRING	RESSORT	FEDER	1
4	12769100/0	VITE	SCREW	VIS	SCHRAUBE	2
5	12150000/0	DADO	NUT	ECROU	MUTTER	1
6	25510022/0	PERNO	PIN	PIVOT	BOLZEN	2
7	24487998/0	COPPIGLIA	COTTER PIN	GOUPILLE	SPLIT	2
21	99900030/0	ASS. KIT PESO ANT.	FRONT WEIGHT KIT	KIT POIDS ANTERIEUR	VORDERGEWICHT VORRICHTUNG	1
22	25519999/0	PESO	WEIGHT	POIDS	GEWICHT	1
23	12760500/0	VITE	SCREW	VIS	SCHRAUBE	3
24	12155000/0	DADO	NUT	ECROU	MUTTER	3
41	99900000/0	ASS. KIT TRAINO	HITCH KIT	KIT DE TRAINAGE	ZUGVORRICHTUNG	1
42	82735502/0	STAFFA SUPPORTO TRAINO DX	BRACKET RIGHT HITCH SUPPORT	ETRIER SUPPORT TRAINAGE DROITE	BUEGEL HALTER FÜR RECHTEN ZUG	1
43	25774213/0	STAFFA SUPPORTO TRAINO SX	BRACKET LEFT HITCH SUPPORT	ETRIER SUPPORT TRAINAGE GAUCHE	BUEGELHALTER FÜR LINKEN ZUG	1
44	82033101/0	BARRA	ROD	BARRE	STANGE	1
45	25510021/0	PERNO	PIN	PIVOT	BOLZEN	1
46	24487999/0	COPPIGLIA	COTTER PIN	GOUPILLE	SPLIT	2