

TC ...

TCP ...

TCR ...

TC ... hy.

TCP ... hy.

TCR ... hy.

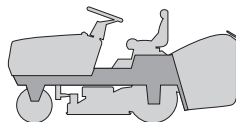
TELAIO
CHASSIS
CHASSIS
RAHMENSATZ

2001

001.0

1 / 2

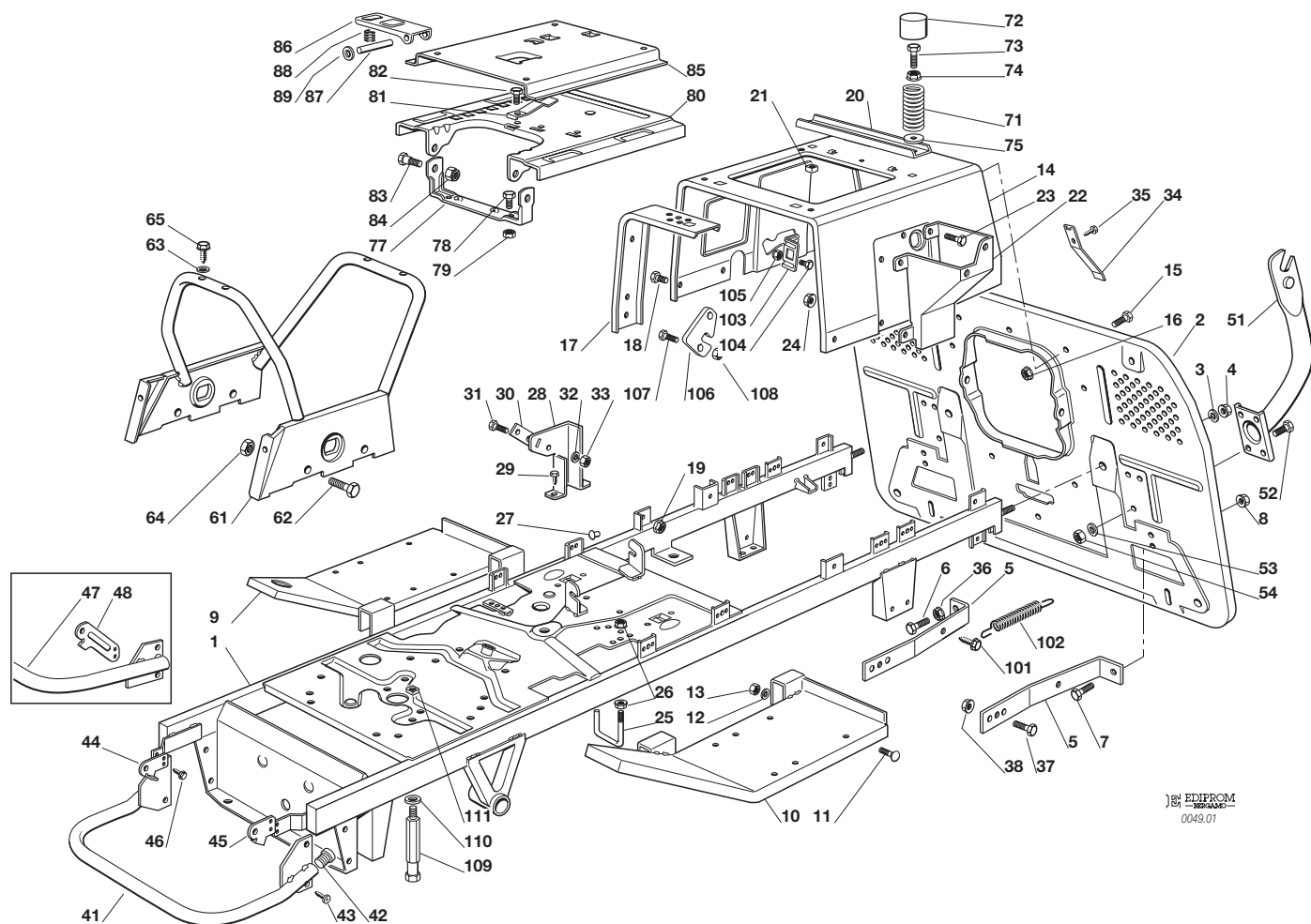
 EDIPROM
 0049.01

N.	CODE	Q.TY	DESCRIZIONE	DESCRIPTION	DESCRIPTION	BESCHREIBUNG
1	82800055/0	1	TELAIO	CHASSIS	CHASSIS	RAHMENSATZ
2	82547011/2	1	PIASTRA	PLATE	PLAQUE	PLATTE
3	12585100/0	2	GROWER	GROWER	GROWER	GROWER
4	12295200/0	2	DADO	NUT	ECROU	MUTTER
5	25774273/0	2	RINFORZO	STIFFENING	REINFORCEMENT	VERSTAERKUNG
6	12691100/0	1	VITE	SCREW	VIS	SCHRAUBE
7	12793102/0	3	VITE	SCREW	VIS	SCHRAUBE
8	12293201/0	4	DADO	NUT	ECROU	MUTTER
9	82510041/0	1	SUPPORTO PEDANA DESTRA	RIGHT FOOTBOARD SUPPORT	MARCHEPIED DROITE SUPPORT	RECHTE FUSSBRETTHALTER
10	82510043/0	1	SUPPORTO PEDANA SINISTRA	LEFT FOOTBOARD SUPPORT	SUPPORT MARCHEPIED GAUCHE	LINKE FUSSBRETTHALTER
11	12815245/0	4	VITE	SCREW	VIS	SCHRAUBE
12	12523040/0	4	ROSETTA	WASHER	RONDELLE	SCHEIBE
13	12154510/0	4	DADO	NUT	ECROU	MUTTER
14	25785133/1	1	SUPPORTO SEDILE	SEAT SUPPORT	SUPPORT SIEGE	SITZHALTER
15	12791011/0	5	VITE	SCREW	VIS	SCHRAUBE
16	12292102/0	5	DADO	NUT	ECROU	MUTTER
17	25650065/0	2	RINFORZO	STIFFENING	REINFORCEMENT	VERSTAERKUNG
18	12791011/0	6	VITE	SCREW	VIS	SCHRAUBE
19	12292102/0	6	DADO	NUT	ECROU	MUTTER
20	25650067/0	1	RINFORZO	STIFFENING	REINFORCEMENT	VERSTAERKUNG
21	12360420/0	2	DADO	NUT	ECROU	MUTTER
22	25785137/0	1	SUPPORTO	SUPPORT	SUPPORT	HALTER
23	12791011/0	4	VITE	SCREW	VIS	SCHRAUBE
24	12292102/0	4	DADO	NUT	ECROU	MUTTER
25	25580019/0	1	PIOLO GUIDACINGHIA	BELT GUIDE	GUIDE DE COURROIRE	RIEMENFÜHRUNG
26	12292102/0	2	DADO	NUT	ECROU	MUTTER
27	27275000/0	1	GOMMINO	GROMMET	CAOUTCHOUC	GUMMI
28	25785141/0	1	SUPPORTO	SUPPORT	SUPPORT	HALTER
29	12735110/0	2	VITE	SCREW	VIS	SCHRAUBE



N.	CODE	Q.TY	DESCRIZIONE	DESCRIPTION	DESCRIPTION	BESCHREIBUNG
30	27546019/0	1	PIASTRINA <i>(hydro)</i>	PLATE <i>(hydro)</i>	PLAQUETTE <i>(hydro)</i>	PLATTE <i>(hydro)</i>
31	12735597/0	2	VITE <i>(hydro)</i>	SCREW <i>(hydro)</i>	VIS <i>(hydro)</i>	SCHRAUBE <i>(hydro)</i>
32	12581100/0	2	ROSETTA <i>(hydro)</i>	WASHER <i>(hydro)</i>	RONDELLE <i>(hydro)</i>	SCHEIBE <i>(hydro)</i>
33	12290791/0	2	DADO <i>(hydro)</i>	NUT <i>(hydro)</i>	ECROU <i>(hydro)</i>	MUTTER <i>(hydro)</i>
34	25430238/0	1	MOLLA	SPRING	RESSORT	FEDER
35	12731580/0	1	VITE	SCREW	VIS	SCHRAUBE
36	12293200/0	1	DADO	NUT	ECROU	MUTTER
37	12793102/0	2	VITE	SCREW	VIS	SCHRAUBE
38	12293201/0	2	DADO	NUT	ECROU	MUTTER
41	82869006/1	1	PROTEZIONE SILENZIATORE	MUFFLER PROTECTION	PROTECTION SILENCIEUX	AUSPUFFSCHUTZ
42	18566110/0	2	PUNTALE	CAP	BOUCHON	PFRÖPFEN
43	12734995/0	4	VITE	SCREW	VIS	SCHRAUBE
44	25547089/0	1	PIASTRINA DESTRA	RIGHT PLATE	PLAQUE DROITE	RECHTE PLATTE
45	25547091/0	1	PIASTRINA SINISTRA	LEFT PLATE	PLAQUE GAUCHE	LINKE PLATTE
46	12731580/0	4	VITE	SCREW	VIS	SCHRAUBE
47	82869015/0	1	PROTEZIONE SILENZIATORE <i>(TCR - 18 HP B&S)</i>	MUFFLER PROTECTION <i>(TCR - 18 HP B&S)</i>	PROTECTION SILENCIEUX <i>(TCR - 18 HP B&S)</i>	AUSPUFFSCHUTZ <i>(TCR - 18 HP B&S)</i>
48	25547099/0	2	PIASTRINA <i>(TCR - 18 HP B&S)</i>	PLATE <i>(TCR - 18 HP B&S)</i>	PLAQUE <i>(TCR - 18 HP B&S)</i>	PLATTE <i>(TCR - 18 HP B&S)</i>
51	82774225/1	2	SUPPORTO	SUPPORT	SUPPORT	HALTER
52	12792611/0	6	VITE	SCREW	VIS	SCHRAUBE
53	12523060/0	6	RONDELLA	WASHER	RONDELLE	SCHEIBE
54	12293201/0	6	DADO	NUT	ECROU	MUTTER
61	82650041/1	1	TELAIO CENTRALE	CHASSIS	CHASSIS	RAHMENSATZ
62	12792611/0	4	VITE	SCREW	VIS	SCHRAUBE
63	12521330/0	4	ROSETTA	WASHER	RONDELLE	SCHEIBE
64	12293201/0	4	DADO	NUT	ECROU	MUTTER
65	12731350/0	4	VITE	SCREW	VIS	SCHRAUBE
71	25430205/0	2	MOLLA	SPRING	RESSORT	FEDER
72	25122000/1	2	CUFFIA	HOOD	PROTECTEUR	SCHUTZKASTEN
73	25943001/0	2	VITE	SCREW	VIS	SCHRAUBE
74	12293201/0	2	DADO	NUT	ECROU	MUTTER
75	12523070/0	2	ROSETTA	WASHER	RONDELLE	SCHEIBE
77	82774207/0	1	STAFFA SUPP. SEDILE	SEAT CLAMP SUPPORT	ETRIER SUPPORT SIEGE	BRIDE F. SITZHALTER
78	12792611/0	2	VITE	SCREW	VIS	SCHRAUBE
79	12293201/0	2	DADO	NUT	ECROU	MUTTER
80	25785149/0	1	SUPP. SEDILE FISSO	FIXED SEAT SUPP.	SUPPORT SIEGE FIXE	FEST SITZHALTER
81	25430203/0	1	MOLLA ARRESTO	SPRING	RESSORT D'ARRET	RASTFEDER
82	12731580/0	1	VITE	SCREW	VIS	SCHRAUBE
83	22524970/1	2	PERNO	PIN	PIVOT	BOLZEN
84	12155010/0	2	DADO	NUT	ECROU	MUTTER
85	25785147/0	1	SUPPORTO SEDILE	SEAT SUPPORT	SUPPORT SIEGE	SITZHALTER
86	25318109/0	1	LEVA ARRESTO	STOP LEVER	LEVIER D'ARRET	ABSTELLHEBEL
87	25510000/0	1	PERNO	PIN	PIVOT	BOLZEN
88	25430202/0	1	MOLLA	SPRING	RESSORT	FEDER
89	12604897/0	2	RONDELLA	WASHER	RONDELLE	SCHEIBE

Nei modelli con innesto delle lame a leva:

For models with engagement of the blades by lever:

Dans les modèles avec embrayage des lames à levier:

Bei Modellen mit Hebelschaltung der Messer:

101	12735120/0	1	VITE	SCREW	VIS	SCHRAUBE
102	25430235/0	1	MOLLA	SPRING	RESSORT	FEDER
103	25755016/0	1	SQUADRETTA	BRACKET	EQUERRE-SUPPORT	WINKEL
104	12789000/0	2	VITE	SCREW	VIS	SCHRAUBE
105	12154330/0	2	DADO	NUT	ECROU	MUTTER
106	25486020/0	1	PATTINO	SHOE	BLOC DE GLISSEMENT	GLEITBLOCK
107	12788910/0	2	VITE	SCREW	VIS	SCHRAUBE
108	12154330/0	2	DADO	NUT	ECROU	MUTTER
109	25580014/0	2	PIOLO GUIDACINGHIA	BELT GUIDE	GUIDE DE COURROIRE	RIEMENFÜHRUNG
110	12523060/0	2	ROSETTA	WASHER	RONDELLE	SCHEIBE
111	12360425/0	2	DADO	NUT	ECROU	MUTTER

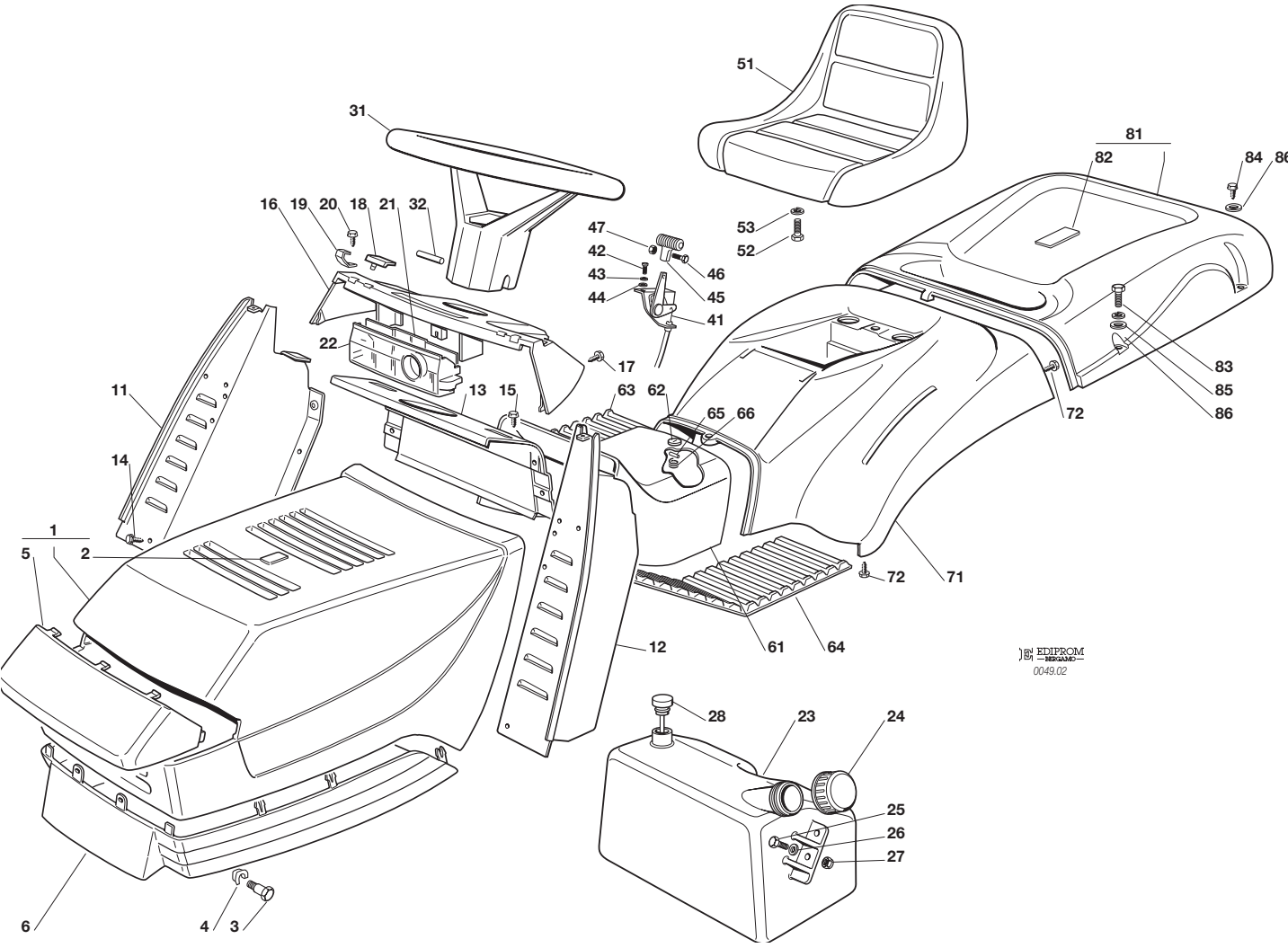
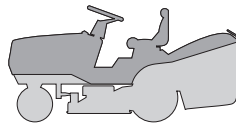

EDIPROM
-REGAL-
0049.02

N.	CODE	Q.TY	DESCRIZIONE	DESCRIPTION	DESCRIPTION	BESCHREIBUNG
----	------	------	-------------	-------------	-------------	--------------

1	82076802/1	1	COFANO SUPERIORE ROSSO	UPPER ENGINE HOOD RED	CAPOT SUPERIEURE ROUGE	OBERHAUBESATZ ROT
	82076803/0		VERDE	GREEN	ROUGE	GRÜN
	82076806/0		GIALLO	YELLOW	JAUNE	GELB
	82076808/0		BLU	BLUE	BLEU	BLAU
2	25547016/1	1	PIASTRINA ROSSA	PLATE RED	PLAQUE ROUGE	PLATTE ROT
	25547015/0		VERDE	GREEN	ROUGE	GRÜN
	25547014/0		GIALLA	YELLOW	VERT	GELB
	25547024/0		BLU	BLUE	JAUNE	BLAU
3	25510023/1	2	PERNO	PIN	PIVOT	BOLZEN
4	12436050/0	2	PIASTRINA	PLATE	PLAQUE	PLATTE
5	25410858/0	1	MASCHERINA	GRILL	PANNEAU	SCHUTZ
6	25076802/0	1	COFANO INFERIORE	LOWER ENGINE HOOD	CAPOT INFERIEURE	UNTERHAUBESATZ
11	82785022/5	1	SUPP. CRUSCOTTO DESTRO	RIGHT DASHBOARD SUPP.	SUPPORT TABLEAU DROITE	RECHTER KONSOLEHALTER
12	82785021/4	1	SUPP. CRUSCOTTO SIN.	LEFT DASHBOARD SUPP.	SUPPORT TABLEAU GAUCHE	LINKER KONSOLEHALTER
13	82785023/1	1	SUPP. CRUSCOTTO CENTR.	CENTRAL DASHBOARD SUPP	SUPPORT TABLEAU CENTR.	ZENTR. KONSOLE HALTER
14	12735110/0	2	VITE	SCREW	VIS	SCHRAUBE
15	12735110/0	4	VITE	SCREW	VIS	SCHRAUBE
16	25120152/1	1	CRUSCOTTO	DASHBOARD	TABLEAU DE BORD	KONSOLE
17	12728440/0	4	VITE	SCREW	VIS	SCHRAUBE
18	25260000/0	2	GOMMINO	GROMMET	PROTECTION	SCHUTZ
19	25430215/0	2	MOLLA AGGANCI	COUPLING SPRING	RESSORT ACCROCHAGE	KUPPLUNGSFEDER
20	12728440/0	2	VITE	SCREW	VIS	SCHRAUBE
21	25600009/0	1	PROTEZIONE SCHEDA	CARD PROTECTION	PROTECTION DE CARTE	KARTESCHUTZ
22	25600051/0	1	PROTEZIONE SCHEDA	CARD PROTECTION	PROTECTION DE CARTE	KARTESCHUTZ
23	25735110/2	1	SERBATOIO	TANK	RESERVOIR	TANK
			12 - 12,5 - 13 - 13,5 HP B&S	12 - 12,5 - 13 - 13,5 HP B&S	12 - 12,5 - 13 - 13,5 HP B&S	12 - 12,5 - 13 - 13,5 HP B&S
			15,5 - 16 - 17 HP B&S	15,5 - 16 - 17 HP B&S	15,5 - 16 - 17 HP B&S	15,5 - 16 - 17 HP B&S
			13 - 15 HP TECUMSEH	13 - 15 HP TECUMSEH	13 - 15 HP TECUMSEH	13 - 15 HP TECUMSEH
			18 - 20 - 22 HP B&S	18 - 20 - 22 HP B&S	18 - 20 - 22 HP B&S	18 - 20 - 22 HP B&S
24	25795000/0	1	TAPPO	CAP	BOUCHON	TANKVERSCHLUSS
25	12788910/0	2	VITE	SCREW	VIS	SCHRAUBE
26	12523020/0	2	RONDELLA	WASHER	RONDELLE	SCHIBE
27	12154320/0	2	DADO	NUT	ECROU	MUTTER



N.	CODE	Q.TY	DESCRIZIONE	DESCRIPTION	DESCRIPTION	BESCHREIBUNG
28	25290000/0	1	INDICATORE LIVELLO 18 - 20 - 22 HP B&S	FUEL LEVEL INDICATOR 18 - 20 - 22 HP B&S	INDICATEUR NIVEAU 18 - 20 - 22 HP B&S	KRAFTSTOFFMESSER 18 - 20 - 22 HP B&S
31	25961200/0	1	VOLANTE	STEERING WHEEL	VOLANT	LENKRAD
32	12620299/0	1	SPINA	PIN	GOUPILLE	STIFT
41	82000200/1	1	ACCELERATORE 12 - 12,5 - 13 - 13,5 HP B&S 15,5 - 16 - 17 HP B&S 13 - 15 HP TECUMSEH 18 - 20 - 22 HP B&S	ACCELERATOR 12 - 12,5 - 13 - 13,5 HP B&S 15,5 - 16 - 17 HP B&S 13 - 15 HP TECUMSEH 18 - 20 - 22 HP B&S	ACCELERATEUR 12 - 12,5 - 13 - 13,5 HP B&S 15,5 - 16 - 17 HP B&S 13 - 15 HP TECUMSEH 18 - 20 - 22 HP B&S	GAS ZUG 12 - 12,5 - 13 - 13,5 HP B&S 15,5 - 16 - 17 HP B&S 13 - 15 HP TECUMSEH 18 - 20 - 22 HP B&S
42	12788512/0	2	VITE	SCREW	VIS	SCHRAUBE
43	12581200/0	2	GROWER	GROWER	GROWER	GROWER
44	12521310/0	2	RONDELLA	WASHER	RONDELLE	SCHLEIBE
45	25394501/0	1	MANOPOLINA	HANDLE	POIGNE	GRIFF
46	12726388/0	1	VITE	SCREW	VIS	SCHRAUBE
47	12290800/0	1	DADO	NUT	ECROU	MUTTER
48	25090000/1	1	COMANDO STARTER 18 - 20 - 22 HP B&S	STARTER DRIVE 18 - 20 - 22 HP B&S	COMMANDE STARTER 18 - 20 - 22 HP B&S	STARTER BETAETIGUNG 18 - 20 - 22 HP B&S
51	25722450/1	1	SEDILE	SEAT	SIEGE	SITZ
52	12793101/0	4	VITE	SCREW	VIS	SCHRAUBE
53	12583500/0	4	GROWER	GROWER	GROWER	GROWER
61	25110136/0	1	COPERTURA CENTRALE ROSSO	COVER RED	COUVRE ROUGE	KAPPE ROT
	25110135/0		VERDE	GREEN	VERT	GRÜN
	25110134/0		GIALLO	YELLOW	JAUNE	GELB
	25110132/0		BLU	BLUE	BLEU	BLAU
61	25110239/0	1	COPERTURA CENTR. (hydro) ROSSO	COVER (hydro) RED	COUVRE (hydro) ROUGE	KAPPE (hydro) ROT
	25110240/0		VERDE	GREEN	VERT	GRÜN
	25110241/0		GIALLO	YELLOW	JAUNE	GELB
	25110242/0		BLU	BLUE	BLEU	BLAU
62	25580020/0	1	PERNO	PIVOT	GOUJON	STIFT
63	25110270/0	1	COPRIPEDANA DESTRA	RIGHT FOOTBOARD COVER	COUVRE MARCHEPIED DRO.	RECHTE FUSSBRETTDECKEL
64	25110260/2	1	COPRIPEDANA SINISTRA	LEFT FOOTBOARD COVER	COUVRE MARCHEPIED GAU.	LINKE FUSSBRETTDECKEL
65	12642450/0	1	SPINA	PIN	GOUPILLE	STIFT
66	25430237/0	1	MOLLA	SPRING	RESSORT	FEDER
72	12735402/0	4	VITE	SCREW	VIS	SCHRAUBE
81	82110207/0	1	COPERTURA SACCO ROSSO	GRASS-CATCHER COVER RED	COUVRE-BAC ROUGE	SACKKAPPE ROT
	82110208/0		VERDE	GREEN	VERT	GRÜN
	82110209/0		GIALLO	YELLOW	JAUNE	GELB
	82110210/0		BLU	BLUE	BLEU	BLAU
82	25547016/1	1	PIASTRINA ROSSA	PLATE RED	PLAQUE ROUGE	PLATTE ROT
	25547015/0		VERDE	GREEN	VERT	GRÜN
	25547014/0		GIALLA	YELLOW	JAUNE	GELB
	25547024/0		BLU	BLUE	BLEU	BLAU
83	12674701/0	2	VITE	SCREW	VIS	SCHRAUBE
84	12729601/0	4	VITE	SCREW	VIS	SCHRAUBE
85	12582101/0	2	GROWER	GROWER	GROWER	GROWER
86	12521331/0	6	RONDELLA	WASHER	RONDELLE	SCHLEIBE
			Nei modelli con innesto delle lame a leva:	For models with engagement of the blades by lever:	Dans les modèles avec embrayage des lames à levier:	Bei Modellen mit Hebelschaltung der Messer:
71	25110148/0	1	COPERTURA RUOTE ROSSO	WHEELS COVER RED	COUVRE-ROUES ROUGE	RADENKAPPE ROT
	25110147/0		VERDE	GREEN	VERT	GRÜN
	25110146/0		GIALLO	YELLOW	JAUNE	GELB
	25110144/0		BLU	BLUE	BLEU	BLAU
71	25110233/1	1	COPERTURA RUOTE (hydro) ROSSO	WHEELS COVER (hydro) RED	COUVRE-ROUES (hydro) ROUGE	RADENKAPPE (hydro) ROT
	25110234/1		VERDE	GREEN	VERT	GRÜN
	25110235/1		GIALLO	YELLOW	JAUNE	GELB
	25110236/1		BLU	BLUE	BLEU	BLAU
			Nei modelli con innesto delle lame elettromagnetico:	For models with engagement of the blades by electromagnetic clutch:	Dans les modèles avec embrayage des lames électromagnétique:	Bei Modellen mit elektromagnetischer Schaltung der Messer:
71	25110141/0	1	COPERTURA RUOTE ROSSO	WHEELS COVER RED	COUVRE-ROUES ROUGE	RADENKAPPE ROT
	25110140/0		VERDE	GREEN	VERT	GRÜN
	25110139/0		GIALLO	YELLOW	JAUNE	GELB
	25110137/0		BLU	BLUE	BLEU	BLAU
71	25110245/1	1	COPERTURA RUOTE (hydro) ROSSO	WHEELS COVER (hydro) RED	COUVRE-ROUES (hydro) ROUGE	RADENKAPPE (hydro) ROT
	25110246/1		VERDE	GREEN	VERT	GRÜN
	25110247/1		GIALLO	YELLOW	JAUNE	GELB
	25110248/1		BLU	BLUE	BLEU	BLAU

TC ...

TCP ...

TCR ...

TC ... hy.

TCP ... hy.

TCR ... hy.

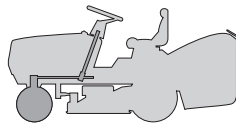

STERZO
STEERING
BARRE DE DIRECTION
LENKGETRIEBE

2001

003.0

1 / 2

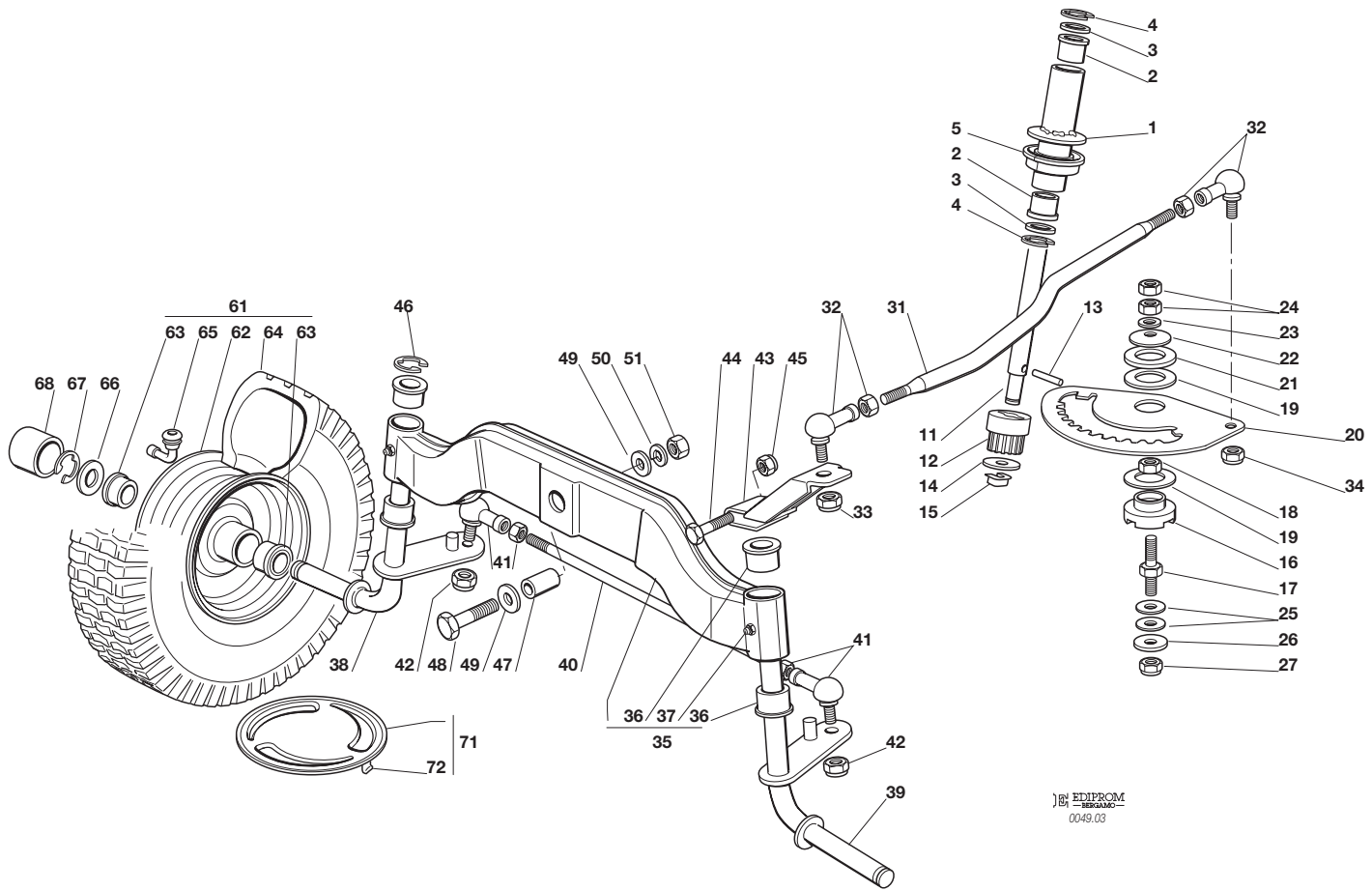

EDIPROM
0049.03

N.	CODE	Q.TY	DESCRIZIONE	DESCRIPTION	DESCRIPTION	BESCHREIBUNG
1	82869013/0	1	TUBO GUIDA PIANTONE	GUIDE TUBE	TUBE	ROHR
2	25040601/0	2	BUSSOLA	BUSH	DOUILLE	BÜCHSE
3	25670006/0	2	RONDELLA	WASHER	RONDELLE	SCHEIBE
4	12001000/0	2	SEEGER	SEEGER	SEEGER	SEEGER
5	25040602/0	2	BUSSOLA	BUSH	DOUILLE	BÜCHSE
11	25520002/1	1	PIANTONE	STEERING COLUMN	TUBE DE DIRECTION	LENKUNGSÄULE
12	25570000/0	1	PIGNONE	PINION	PIGNON	RITZEL
13	12622650/0	1	SPINA	PIN	GOUPILLE	STIFT
14	12521370/0	1	RONDELLA	WASHER	RONDELLE	SCHEIBE
15	12436030/0	1	PIASTRINA	PLATE	PLAQUETTE	PLATTECHEN
16	25040617/0	1	BUSSOLA	BUSH	DOUILLE	BÜCHSE
17	25510065/0	1	PERNO	PIN	PIVOT	BOLZEN
18	12295200/0	1	DADO	NUT	ECROU	MUTTER
19	25670012/0	2	RONDELLA	WASHER	RONDELLE	SCHEIBE
20	25735507/0	1	SETTORE	STEERING SHAFT	ARBRE DIRECTION	LENKUNGSWELLE
21	25670014/0	1	RONDELLA	WASHER	RONDELLE	SCHEIBE
22	22160400/0	1	DISCO ELASTICO	ELASTIC WASHER	DISQUE ELASTIQUE	FEDERSCHEIBE
23	12521360/0	1	ROSETTA	WASHER	RONDELLE	SCHEIBE
24	12295200/0	2	DADO	NUT	ECROU	MUTTER
25	22672150/0	2	RONDELLA	WASHER	RONDELLE	SCHEIBE
26	12523080/0	1	RONDELLA	WASHER	RONDELLE	SCHEIBE
27	12156602/0	1	DADO	NUT	ECROU	MUTTER
31	25033003/1	1	ASTA COMANDO STERZO	STEERING ROD	BARRE DE DIRECTION	LENKUNGSSTAB
32	22746600/0	2	SNODO	JOINT	JOINT	GELENK
33	12156602/0	1	DADO	NUT	ECROU	MUTTER
34	12156602/0	1	DADO	NUT	ECROU	MUTTER
35	82034001/2	1	BILANCIERE COMPLETO (CON 36 + 37)	EQUALIZER WITH BUSH (WITH 36 + 37)	BALANCIER AVEC (AVEC 36 + 37)	KIPPHEBEL (MIT 36 + 37)



N.	CODE	Q.TY	DESCRIZIONE	DESCRIPTION	DESCRIPTION	BESCHREIBUNG
36	25034002/1	4	BRONZINA	BRASS	COUSSINET	BÜCHSE
37	12379511/0	2	INGRASSATORE	GREASE DISPENSER	GRAISSEUR	FETTBUCHSE
38	82230349/0	1	FUSELLO DESTRO	RIGHT STUB AXLE	FUSEAU DROITE	RECHTER ACHSSCHENKEL
39	82230348/0	1	FUSELLO SINISTRO	LEFT STUB AXLE	FUSEAU GAUCHE	LINKER ACHSSCHENKEL
40	25840001/0	1	TIRANTE	TIE ROD	TIRANT	KUPPLUNG
41	22746600/0	2	SNODO	JOINT	JOINT	GELENK
42	12156602/0	2	DADO	NUT	ECROU	MUTTER
43	82318101/0	1	LEVA COMANDO	LEVER	LEVIER	HEBEL
44	12691700/0	1	VITE	SCREW	VIS	SCHRAUBE
45	12155000/0	1	DADO	NUT	ECROU	MUTTER
46	12001000/0	1	ANELLO ELASTICO	SNAP RING	ANNEAU RESSORT	SPRENGRING
47	25160005/0	1	DISTANZIALE	SPACER	ENTRETOISE	ENTFERNUNGSSTUECK
48	12694100/0	1	VITE	SCREW	VIS	SCHRAUBE
49	12521390/0	2	RONDELLA	WASHER	RONDELLE	SCHEIBE
50	12587900/0	1	GROWER	GROWER	GROWER	GROWER
51	12295800/0	1	DADO	NUT	ECROU	MUTTER
61	☛	2	RUOTA ANTERIORE	FRONT WHEEL	ROUE AVANT	VORDERRAD
	82680002/1		TURF SAVER CARLISLE	TURF SAVER CARLISLE	TURF SAVER CARLISLE	TURF SAVER CARLISLE
	82680005/1		DELI TIRE	DELI TIRE	DELI TIRE	DELI TIRE
62	82000590/0	2	CERCHIO RUOTA	RIMM	BANDAGE ROUE	VORDERRAD FELGER
63	25122200/1	4	CUSCINETTO	BEARING	ROULEMENT	LAGER
64	☛	2	PNEUMATICO	TIRE	PNEU	REIFEN
	25590000/0		TURF SAVER CARLISLE	TURF SAVER CARLISLE	TURF SAVER CARLISLE	TURF SAVER CARLISLE
	25590002/0		DELI TIRE	DELI TIRE	DELI TIRE	DELI TIRE
65	25950002/0	2	VALVOLA	VALVE	SOUPAPE	VENTIL
66	25670005/1	2	RONDELLA	WASHER	RONDELLE	SCHEIBE
67	12001000/0	2	ANELLO ELASTICO	SNAP RING	ANNEAU RESSORT	SPRENGRING
68	22110230/0	2	COPRIMOZZO	HUB COVER	COUVRE MOYEU	RADNABE DECKEL
71	82110250/1	2	ASS. COPRIDISCO RUOTA ANTERIORE (TC - TCR)	FRONT WHEEL COVERENS. ASS.Y (TC - TCR)	COUVRE DISQUE ROUE ANTER. (TC - TCR)	VORRDERRAD DECKEL (TC - TCR)
	82110252/0	2	ASS. COPRIDISCO RUOTA ANTERIORE (TCP)	FRONT WHEEL COVERENS. ASS.Y (TCP)	COUVRE DISQUE ROUE ANTERIEURE (TCP)	VORRDERRAD DECKEL (TCP)
72	25430209/0	8	MOLLA AGGANCIAMENTO	SPRING	RESSORT	FEDER

TC ...

TCP ...

TCR ...

TC ... hy.

TCP ... hy.

TCR ... hy.

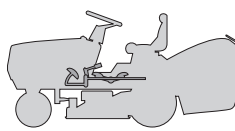

COMANDO TRASMISSIONE E FRENO
DRIVE AND BRAKE CONTROLS
COMMANDE TRANSMISSION ET FREIN
GETRIEBE UND BREMSE ANTRIEB

2001

004Y.0

1 / 2

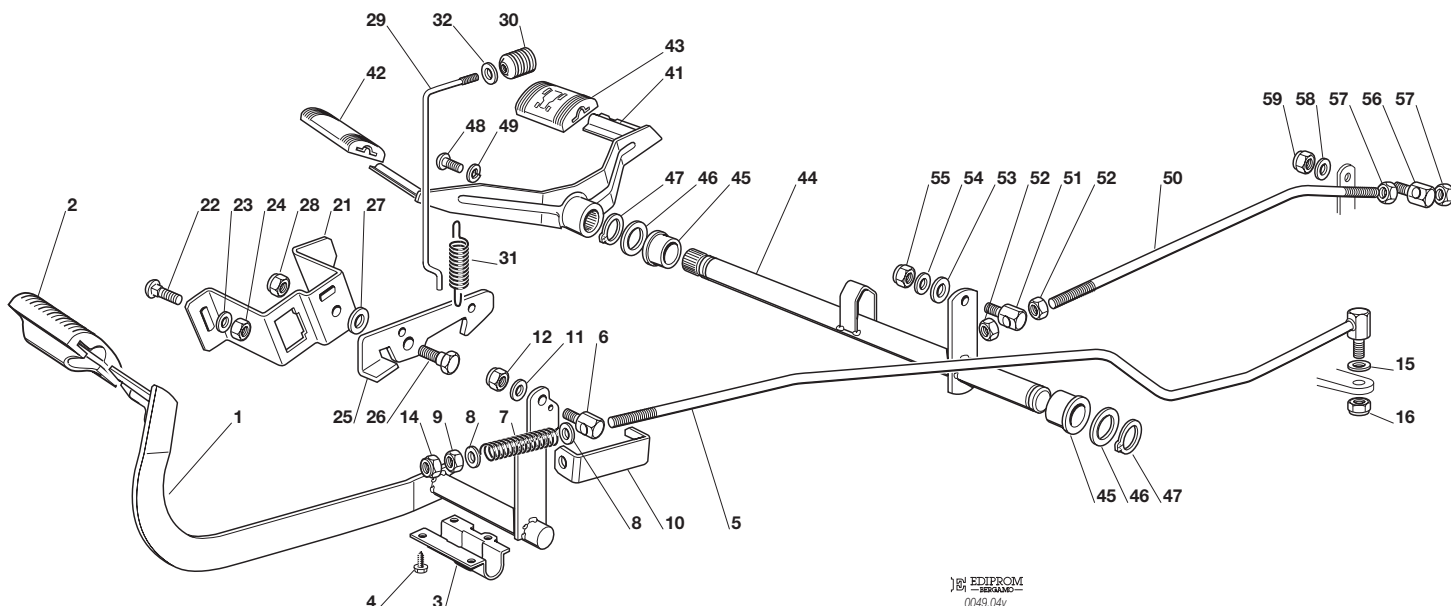

EDIPROM
0049.04y

N.	CODE	Q.TY	DESCRIZIONE	DESCRIPTION	DESCRIPTION	BESCHREIBUNG
----	------	------	-------------	-------------	-------------	--------------

1	82500011/1	1	PEDALE	PEDAL	PEDAL	PEDAL
2	25110267/0	1	COPRISTAFFA	CLAMP COVER	COUVRE ETRIER	BRIDEDECKEL
3	25547081/0	1	PIASTRINA	PLATE	PLAQUE	PLATTE
4	12731601/0	4	VITE	SCREW	VIS	SCHRAUBE
5	82000487/0	1	ASTA	ROD	BARRE	STANGE
6	25510052/0	1	PERNO	PIN	PIVOT	BOLZEN
7	25430236/0	1	MOLLA	SPRING	RESSORT	FEDER
8	12521360/0	2	RONDELLA	WASHER	RONDELLE	SCHEIBE
9	12156602/0	1	DADO	NUT	ECROU	MUTTER
10	25774275/0	1	STAFFA	CLAMP	ETRIER	BRIDE
11	12521350/0	1	RONDELLA	WASHER	RONDELLE	SCHEIBE
12	12155000/0	1	DADO	NUT	ECROU	MUTTER
15	12521350/0	1	RONDELLA	WASHER	RONDELLE	SCHEIBE
16	12155000/0	1	DADO	NUT	ECROU	MUTTER

21	25785143/0	1	SUPPORTO	SUPPORT	SUPPORT	HALTER
22	12815210/0	2	VITE	SCREW	VIS	SCHRAUBE
23	12523040/0	1	RONDELLA	WASHER	RONDELLE	SCHEIBE
24	12154510/0	2	DADO	NUT	ECROU	MUTTER
25	25253001/0	1	GANCIO	HOOK	CROCHET	HAKEN
26	22524970/1	1	PERNO	PIN	PIVOT	BOLZEN
27	25670011/0	1	RONDELLA	WASHER	RONDELLE	SCHEIBE
28	12155000/0	1	DADO	NUT	ECROU	MUTTER
29	25033034/0	1	ASTA	ROD	BARRE	STANGE
30	25394509/1	1	MANOPOLA	KNOB	POIGNEE	KNOPF
31	25430213/0	1	MOLLA	SPRING	RESSORT	FEDER
32	12523020/0	1	RONDELLA	WASHER	RONDELLE	SCHEIBE

41	82500013/0	1	PEDALE AVANZAMENTO	DRIVE PEDAL	PEDALE TRANSMISSION	GETRIEBEPEDAL
42	25110265/0	1	COPRISTAFFA ANTERIORE	CLAMP COVER FRONT	COUVRE ETRIER AVANT	BRIDEDECKEL VORDE
43	25110266/0	1	COPRISTAFFA POSTERIORE	CLAMP COVER REAR	COUVRE ETRIER ARRIERE	BRIDEDECKEL HINTER



N.	CODE	Q.TY	DESCRIZIONE	DESCRIPTION	DESCRIPTION	BESCHREIBUNG
44	82000481/0	1	ASSE AVANZAMENTO	AXLE	AXE	ACHSE
45	22034523/0	2	BRONZINA	BUSH	DOUILLE	BÜCHSE
46	22672153/0	2	RONDELLA	WASHER	RONDELLE	SCHEIBE
47	12609260/0	2	SEEGER	SEEGER	SEEGER	SEEGER
48	12760600/0	1	VITE	SCREW	VIS	SCHRAUBE
49	12583501/0	1	GROWER	GROWER	GROWER	GROWER
50	25033031/0	1	ASTA	ROD	BARRE	STANGE
51	25510054/0	1	PERNO	PIN	PIVOT	BOLZEN
52	12293200/0	2	DADO	NUT	ECROU	MUTTER
53	12521360/0	1	RONDELLA	WASHER	RONDELLE	SCHEIBE
54	12523040/0	1	RONDELLA	WASHER	RONDELLE	SCHEIBE
55	12154510/0	1	DADO	NUT	ECROU	MUTTER
56	25510054/0	1	PERNO	PIN	PIVOT	BOLZEN
57	12293200/0	2	DADO	NUT	ECROU	MUTTER
58	12523040/0	1	RONDELLA	WASHER	RONDELLE	SCHEIBE
59	12154510/0	1	DADO	NUT	ECROU	MUTTER

TC ...

TCP ...

TCR ...

TC ... hy.

TCP ... hy.

TCR ... hy.

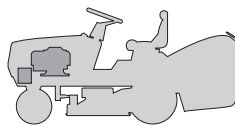

MOTORE
ENGINE
MOTEUR
MOTOR

15 - 15,5 - 16 - 17 HP B&S

2001

005a.0

1 / 2

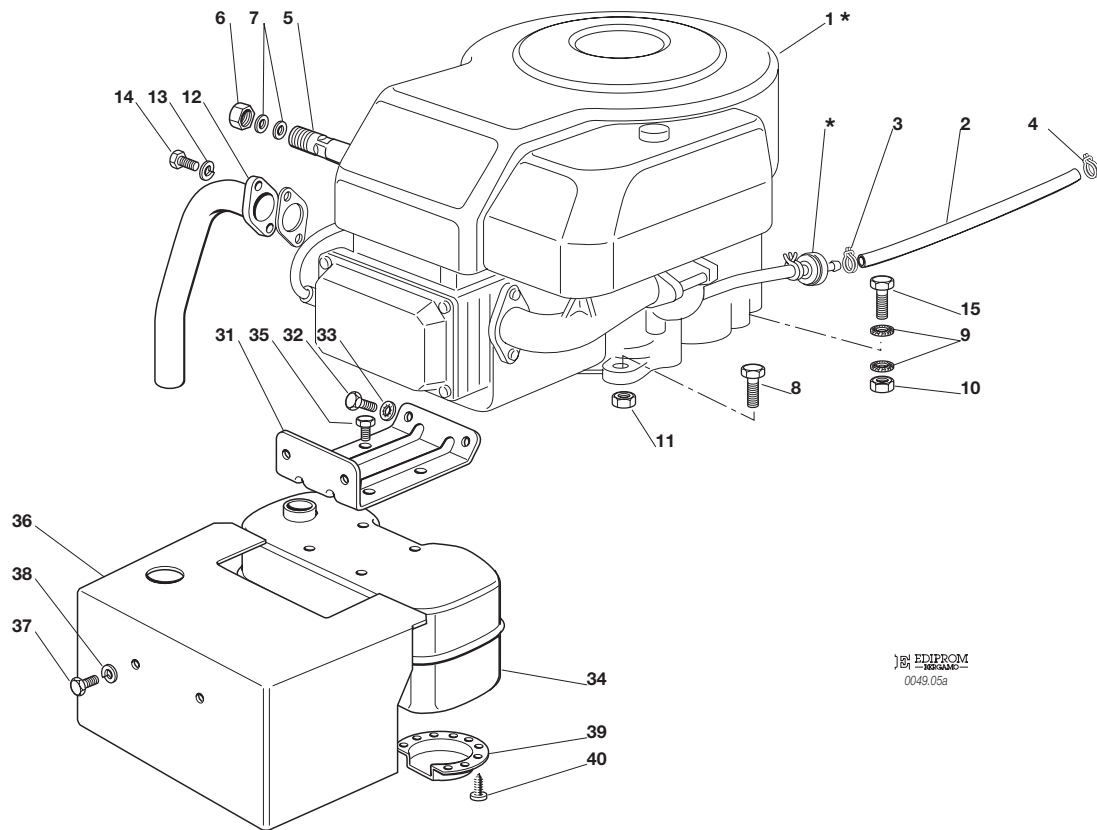

EDIPROM
0049.05a

N.	CODE	Q.TY	DESCRIZIONE	DESCRIPTION	DESCRIPTION	BESCHREIBUNG
1*	—	1	MOTORE	ENGINE	MOTEUR	MOTOR
2	25869016/0	1	TUBO COLLEGAMENTO	CONNECTING TUBE	TUBE DE CONNEXION	VERBINDUNGSRÖHR
3	18375051/1	1	FASCETTA	FAIR LED	FIXATION DE CABLE	KABELBEFESTIGUNG
4	18375053/0	1	FASCETTA	FAIR LED	FIXATION DE CABLE	KABELBEFESTIGUNG
5	25598050/0	1	PROLUNGA SCARICO OLIO	OIL DISCHARGE EXTENSION	EXTENSION RALLONGE DE DECH. HUILE	ÖL ENTLEERUNGSVERLÄEN- GERUNG
6	18737849/0	1	TAPPO PROLUNGA	OIL CAP	BOUCHON HUILE	OELVERSCHLUSS
7	18401001/0	2	GUARNIZIONE	OIL SEAL	GARNITURE	DICHTUNG
8	12691100/0	3	VITE	SCREW	VIS	SCHRAUBE
9	12540260/0	2	RONDELLA	WASHER	RONDELLE	SCHEIBE
10	12293200/0	1	DADO	NUT	ECROU	MUTTER
11	12293201/0	3	DADO	NUT	ECROU	MUTTER
12	18738206/0	1	TUBO RACCORDO SCARICO	EXHAUST CONNECTING TUBE	TUBE DE CONNEXION POUR ECHAPPEMENT	VERBINDUNGSRÖHR FÜR ABGASUNG
13	12583500/0	2	GROWER	GROWER	GROWER	GROWER
14	12735530/0	2	VITE	SCREW	VIS	SCHRAUBE
15	12691115/0	1	VITE	SCREW	VIS	SCHRAUBE
31	82785093/0	1	SUPPORTO SILENZIATORE	MUFFLER SUPPORT	SUPPORT SILENCIEUX	AUSPUFFHALTERSATZ
32	12793102/0	2	VITE	SCREW	VIS	SCHRAUBE
33	12540260/0	2	RONDELLA	WASHER	RONDELLE	SCHEIBE
34	18716132/0	1	SILENZIATORE COMPLETO DI DEFLETTORE	MUFFLER WITH DEFLECTOR	SILENCEUX AVEC DEFLECTEUR	AUSPUFF MIT DEFLEKTOR
35	12735599/0	4	VITE	SCREW	VIS	SCHRAUBE
36	82598009/1	1	PROTEZIONE	GUARD	PROTECTION	SCHUTZE
37	12792611/0	2	VITE	SCREW	VIS	SCHRAUBE
38	12583500/0	2	GROWER	GROWER	GROWER	GROWER
39	18310005/0	1	DEFLETTORE	DEFLECTOR	DEFLECTEUR	DEFLEKTOR
40	12735106/0	4	VITE	SCREW	VIS	SCHRAUBE



TC ... • TCP ... • TCR ... • TC ... hy • TCP ... hy • TCR ... hy

2001

005a.0

2 / 2

N. CODE Q.TY DESCRIZIONE

DESCRIPTION

DESCRIPTION

BESCHREIBUNG

PER LA SOSTITUZIONE DELLE PARTI CONTRASSEGNAE CON «★» RIVOLGERSI AL SERVIZIO ASSISTENZA DEL COSTRUTTORE DEL MOTORE.
TO REPLACE THE PARTS MARKED «★» SEEK ASSISTANCE FROM THE ENGINE MANUFACTURER'S AFTER SALES SERVICE.
POUR LE REMPLACEMENT DES PIÈCES MARQUÉES AVEC «★» S'ADRESSER AU SERVICE APRÈS VENTES DU CONSTRUCTEUR DU MOTEUR.
ZUM AUSTAUSCH DER MIT «★» GEKENNZEICHNETEN TEILE, WENDEN SIE SICH AN DEN KUNDENDIENST DES HERSTELLERS DES MOTOR.

TC ...

TCP ...

TCR ...

TC ... hy.

TCP ... hy.

TCR ... hy.

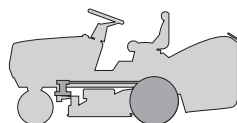

TRASMISSIONE
TRANSMISSION
TRANSMISSION
GETRIEBE

2001

006Y.0

1 / 2

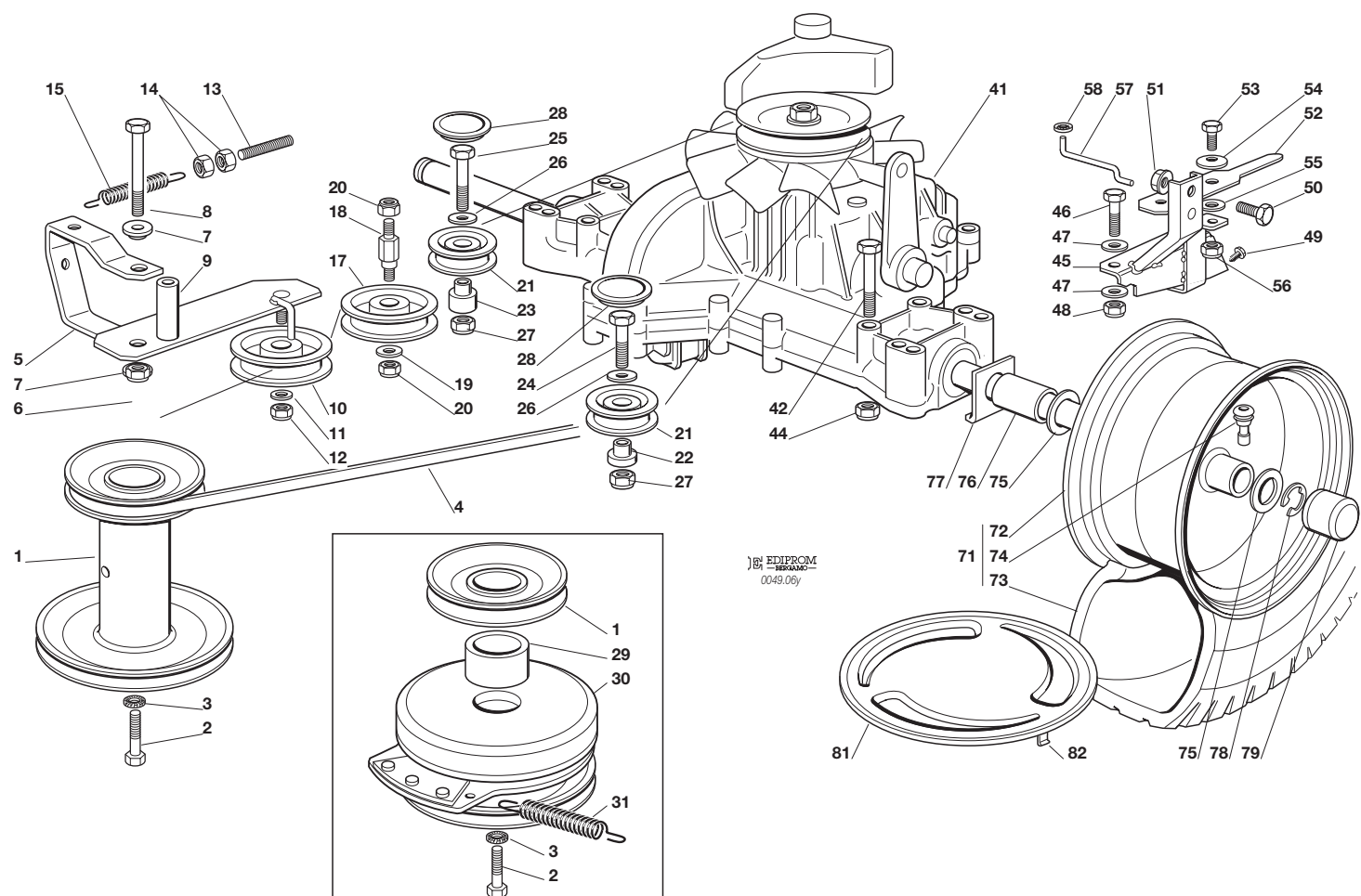

N.	CODE	Q.TY	DESCRIZIONE	DESCRIPTION	DESCRIPTION	BESCHREIBUNG
3	12543000/0	1	ROSETTA	WASHER	RONDELLE	SCHEIBE
4	35062001/0	1	CINGHIA	BELT	COURROIE	RIEMEN
5	82318165/1	1	LEVA	LEVER	LEVIER	HEBEL
6	12692000/0	1	VITE	SCREW	VIS	SCHRAUBE
7	25038002/1	2	BOCCOLA	BUSH	DOUILLE	BÜCHSE
8	12155000/0	1	DADO	NUT	ECROU	MUTTER
9	25160027/0	1	DISTANZIALE	SPACER	ENTRETOISE	ENTFERNUNGSSTÜCK
10	25601554/0	1	PULEGGIA	PULLEY	POULIE	RIEMENSCHLEIBE
11	12523060/0	1	RONDELLA	WASHER	RONDELLE	SCHEIBE
12	12155000/0	1	DADO	NUT	ECROU	MUTTER
13	25840010/1	1	TIRANTE	TIE ROD	TIRANT	SPANNSTANGE
14	12293200/0	2	DADO	NUT	ECROU	MUTTER
15	25430219/0	1	MOLLA	SPRING	RESSORT	FEDER
17	25601555/0	1	PULEGGIA	PULLEY	POULIE	FEDER RIEMENSCHLEIBE
18	25510036/0	1	PERNO	PIN	PIVOT	BOLZEN
19	12523060/0	1	RONDELLA	WASHER	RONDELLE	SCHEIBE
20	12155000/0	2	DADO	NUT	ECROU	MUTTER
21	25601558/2	2	PULEGGIA	PULLEY	POULIE	RIEMENSCHLEIBE
22	25160030/0	1	DISTANZIALE SINISTRO	LEFT SPACER	ENTRETOISE GAUCHE	LINKER ABSTANDSSTÜCK
23	25160024/1	1	DISTANZIALE DESTRO	RIGHT SPACER	ENTRETOISE DROITE	RECHTER ABSTANDSSTÜCK
24	12691115/0	1	VITE	SCREW	VIS	SCHRAUBE
25	12691400/0	1	VITE	RIGHT SCREW	VIS	SCHRAUBE
26	12523060/0	2	RONDELLA	WASHER	RONDELLE	SCHEIBE
27	12155000/0	2	DADO	NUT	ECROU	MUTTER
28	25109521/0	2	COPERCHIO	COVER	COUVERCLE	DECKEL
41★	18400950/1	1	ASSE POSTERIORE	REAR AXLE	AXE ARRIERE	HINTERACHSE
42	12691800/0	4	VITE	SCREW	VIS	SCHRAUBE
44	12154210/0	4	DADO	NUT	ECROU	MUTTER
45	82785109/0	1	SUPPORTO	SUPPORT	SUPPORT	HALTER



N.	CODE	Q.TY	DESCRIZIONE	DESCRIPTION	DESCRIPTION	BESCHREIBUNG
46	12691200/0	1	VITE	SCREW	VIS	SCHRAUBE
47	12521350/0	2	RONDELLA	WASHER	RONDELLE	SCHEIBE
48	12155000/0	1	DADO	NUT	ECROU	MUTTER
49	12735120/0	2	VITE	SCREW	VIS	SCHRAUBE
50	12792611/0	1	VITE	SCREW	VIS	SCHRAUBE
51	12293201/0	1	DADO	NUT	ECROU	MUTTER
52	25318157/0	1	LEVA	LEVER	LEVIER	HEBEL
53	12793102/0	1	VITE	SCREW	VIS	SCHRAUBE
54	12369500/0	1	DISCO ELASTICO	ELASTIC WASHER	DISQUE ELASTIQUE	FEDERSCHEIBE
55	25670011/0	1	RONDELLA	WASHER	RONDELLE	SCHEIBE
56	12155000/0	1	DADO	NUT	ECROU	MUTTER
57	25033033/0	1	ASTA	ROD	BARRE	STANGE
58	12604896/0	1	FISSATORE A CORONA	CROWN FASTENER	FIXATEUR A COURONNE	KRONESCHEIBE
71	82680003/0	2	RUOTA POSTERIORE	REAR WHEEL	ROUE ARRIERE	HINTERRAD
	82680006/0		TURF SAVER CARLISLE DELI TIRE	TURF SAVER CARLISLE DELI TIRE	TURF SAVER CARLISLE DELI TIRE	TURF SAVER CARLISLE DELI TIRE
72	82000592/0	2	CERCHIO RUOTA	RIMM	BANDAGE ROUE	HINTERRAD FELGER
73	25590001/0	2	PNEUMATICO	SHOE	PNEU	REIFEN
	25590003/0		TURF SAVER CARLISLE DELI TIRE	TURF SAVER CARLISLE DELI TIRE	TURF SAVER CARLISLE DELI TIRE	TURF SAVER CARLISLE DELI TIRE
74	25950000/0	2	VALVOLA	VALVE	SOUPAPE	VENTIL
75	25670005/1	4	RONDELLA	WASHER	RONDELLE	SCHEIBE
76	25160023/0	2	DISTANZIALE	SPACER	ENTRETOISE	ENTFERNUNGSSTÜCK
77	25670017/0	2	RONDELLA	WASHER	RONDELLE	SCHEIBE
78	12001010/0	2	ANELLO ELASTICO	SNAP RING	ANNEAU RESSORT	SPRENGRING
79	22110230/0	2	COPRIMOZZO	HUB COVER	COUVRE MOYEU	NABEDECKEL
81	82110251/1	2	COPRIRUOTA POST. (TC - TCR)	REAR WHEEL DECK (TC - TCR)	COUVRE ROUE POST. (TC - TCR)	HINTERRADDECKEL (TC - TCR)
	82110253/0	2	COPRIRUOTA POST. (TCP)	REAR WHEEL DECK (TCP)	COUVRE ROUE POST. (TCP)	HINTERRADDECKEL (TCP)
82	25430209/0	8	MOLLA AGGANCIO	SPRING	RESSORT	FEDER

Nei modelli con innesto delle lame a leva:

For models with engagement of the blades by lever:

Dans les modèles avec embrayage des lames à levier:

Bei Modellen mit Hebelschaltung der Messer:

1	25601568/0	1	PULEGGIA	PULLEY	POULIE	RIEMENSCHLEIBE
2	12737310/0	1	VITE	SCREW	VIS	SCHRAUBE

Nei modelli con innesto delle lame elettromagnetico:

For models with engagement of the blades by electromagnetic clutch:

Dans les modèles avec embrayage des lames électromagnétique:

Bei Modellen mit elektromagnetischer Schaltung der Messer:

1	25601566/0	1	PULEGGIA	PULLEY	POULIE	RIEMENSCHLEIBE
2	12737320/0	1	VITE	SCREW	VIS	SCHRAUBE
29	25160021/0	1	DISTANZIALE	SPACER	ENTRETOISE	ENTFERNUNGSSTÜCK
30	18399060/0	1	FRIZIONE	CLUTC	EMBRAJAGE	KUPPLUNG
31	25430210/0	1	MOLLA	SPRING	RESSORT	FEDER

PER LA SOSTITUZIONE IN GARANZIA DELLE PARTI CONTRASSEGNAE CON «★» RIVOLGERSI AL SERVIZIO ASSISTENZA DEL COSTRUTTORE (TUFF TORQ).

TO REPLACE UNDER GUARANTEE THE PARTS MARKED «★» SEEK ASSISTANCE FROM MANUFACTURER'S AFTER SALES SERVICE (TUFF TORQ).

POUR LE REMPLACEMENT, SOUS GARANTIE DES PIÈCES MARQUÉES AVEC «★» S'ADRESSER AU SERVICE APRÈS VENTES DU CONSTRUCTEUR (TUFF TORQ).

ZUM AUSTAUSCH DER MIT «★» GEKENNZEICHNETEN TEILE IM RAHMEN DER GARANTIE, WENDEN SIE SICH AN DEN KUNDENDIENST DES HERSTELLERS (TUFF TORQ).

TC ...

TCP ...

TCR ...

TC ... hy.

TCP ... hy.

TCR ... hy.

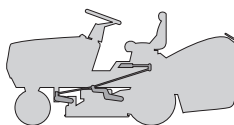

SOLLEVAMENTO PIATTO DI TAGLIO
CUTTING PLATE LIFTING
SOULEVEMENT PLATEAU DE COUPE
SCHNEIDWERKZEUG AUFHEBESATZ

2001

007.0

1 / 2

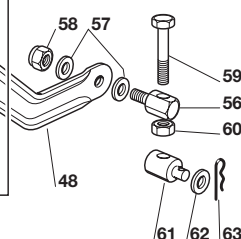
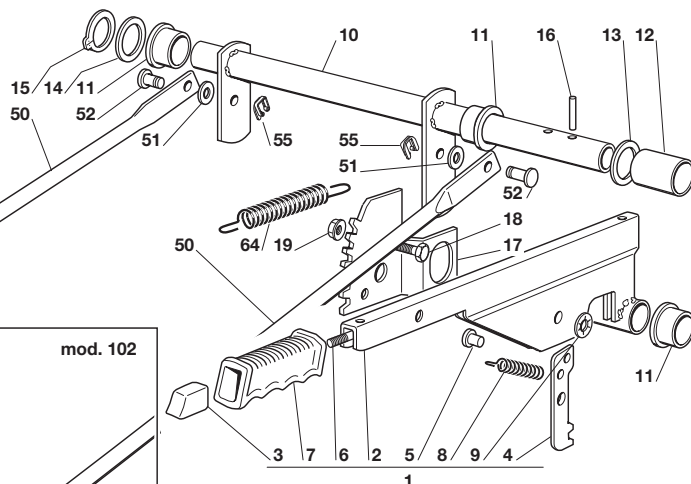
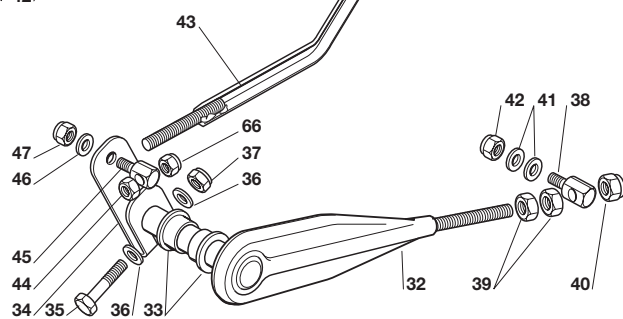
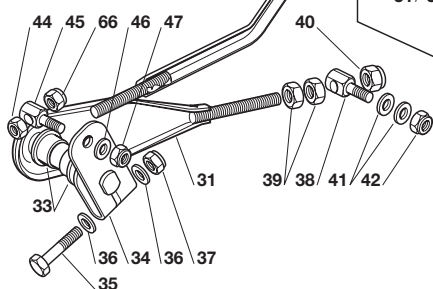
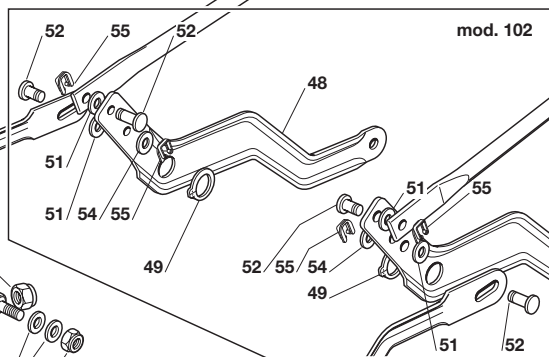
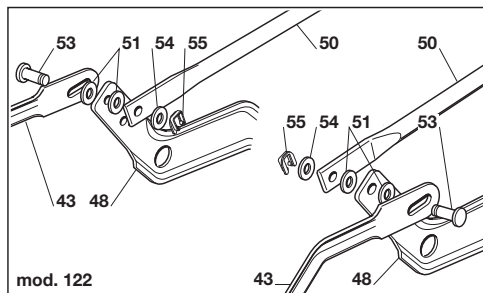

EDIPROM
0049.07

N.	CODE	Q.TY	DESCRIZIONE	DESCRIPTION	DESCRIPTION	BESCHREIBUNG
1	82300002/1	1	ASSIEME LEVA (2 ÷ 9)	LEVER ASS.Y (2 ÷ 9)	ENS. LEVIER (2 ÷ 9)	AUFHEBENHEBEL (2 ÷ 9)
2	82318139/0	1	LEVA	LEVER	LEVIER	HEBEL
3	25605000/1	1	PULSANTE	BUTTON	POUSSOIR	DRUCKKNOPF
4	25470901/0	1	NASELLO	DOG	DECLIC	NASE
5	25510011/0	1	PERNO	PIN	PIVOT	BOLZEN
6	25033002/0	1	ASTA	ROD	TIGE	STAB
7	25394504/1	1	MANOPOLA	KNOB	POIGNEE	GRIFF
8	25430208/0	1	MOLLA	SPRING	RESSORT	FEDER
9	12604899/0	1	FISSATORE A CORONA	CROWN FASTENER	FIXATEUR A COURONNE	KRONESCHEIBE
10	82000479/0	1	ASSE	AXLE	AXE	ACHSE
11	22034523/0	3	BOCCOLA	BUSH	DOUILLE	BÜCHSE
12	25160025/0	1	DISTANZIALE	SPACER	ENTRETOISE	ENTFERNUNGSSTÜCK
13	22672153/0	1	RONDELLA	WASHER	RONDELLE	SCHIBE
14	12521410/0	1	RONDELLA	WASHER	RONDELLE	SCHIBE
15	12609260/0	1	SEEGER	SEEGER	SEEGER	SEEGER
16	12620206/0	2	SPINA	PIN	GOUPILLE	STIFT
17	25735506/1	1	SETTORE	SECTOR	SECTEUR	SEKTOR
18	12792611/0	2	VITE	SCREW	VIS	SCHRAUBE
19	12293201/0	2	DADO	NUT	ECROU	MUTTER
31	82318155/0	1	LEVA ANTERIORE DESTRA (mod. 102)	FRONT RIGHT LEVER (mod. 102)	LEVIER ANT. DROITE (mod. 102)	RECHTER VORDERHEBEL (mod. 102)
	82318159/0	1	LEVA ANTERIORE DESTRA (mod. 122)	FRONT RIGHT LEVER (mod. 122)	LEVIER ANT. DROITE (mod. 122)	RECHTER VORDERHEBEL (mod. 122)
32	82318157/0	1	LEVA ANTERIORE SINISTRA (mod. 102)	FRONT LEFT LEVER (mod. 102)	LEVIER ANT. GAUCHE (mod. 102)	LINKER VORDERHEBEL (mod. 102)
	82318161/0	1	LEVA ANTERIORE SINISTRA (mod. 122)	FRONT LEFT LEVER (mod. 122)	LEVIER ANT. GAUCHE (mod. 122)	LINKER VORDERHEBEL (mod. 122)
33	25040605/0	4	BUSSOLA	BUSH	DOUILLE	BÜCHSE
34	25318161/0	2	LEVA	LEVER	LEVIER	HEBEL
35	12691700/0	2	VITE	SCREW	VIS	SCHRAUBE



N.	CODE	Q.TY	DESCRIZIONE	DESCRIPTION	DESCRIPTION	BESCHREIBUNG
36	12521350/0	4	RONDELLA	WASHER	RONDELLE	SCHEIBE
37	12155000/0	2	DADO	NUT	ECROU	MUTTER
38	25510056/0	2	PERNO	PIN	PIVOT	BOLZEN
39	12295200/0	4	DADO	NUT	ECROU	MUTTER
40	12156602/0	2	DADO	NUT	ECROU	MUTTER
41	25670008/0	4	RONDELLA	WASHER	RONDELLE	SCHEIBE
42	12156602/0	2	DADO	NUT	ECROU	MUTTER
43	82000477/0	2	ASTA COLLEGAMENTO	CONNECTING ROD	TIGE DE CONNEXION	VERBINDUNGSSTAB
44	12155000/0	2	DADO	NUT	ECROU	MUTTER
45	25510055/0	2	PERNO	PIN	PIVOT	BOLZEN
46	12521350/0	2	RONDELLA	WASHER	RONDELLE	SCHEIBE
47	12155000/0	2	DADO	NUT	ECROU	MUTTER
48	25318153/0	2	LEVA POSTERIORE	REAR LEVER	LEVIER ARRIERE	HINTERHEBEL
49	12609255/0	2	SEEGER	SEEGER	SEEGER	SEEGER
50	25033029/0	2	ASTA COLLEGAMENTO	CONNECTING ROD	TIGE DE CONNEXION	VERBINDUNGSSTAB
51	25670011/0	6	RONDELLA	WASHER	RONDELLE	SCHEIBE
52	25510053/0	6	PERNO (mod. 102)	PIN (mod. 102)	PINOT (mod. 102)	BOLZEN (mod. 102)
		2	PERNO (mod. 122)	PIN (mod. 122)	PIVOT (mod. 122)	BOLZEN (mod. 122)
53	25510048/0	2	PERNO (mod. 122)	PIN (mod. 122)	PIVOT (mod. 122)	BOLZEN (mod. 122)
54	12521350/0	2	RONDELLA	WASHER	RONDELLE	SCHEIBE
55	12436050/0	6	PIASTRINA (mod. 102)	PLATE (mod. 102)	PLAQUETTE (mod. 102)	PLATTE (mod. 102)
		4	PIASTRINA (mod. 122)	PLATE (mod. 122)	PLAQUETTE (mod. 122)	PLATTE (mod. 122)
56	25510056/0	2	PERNO	PIN	PIVOT	BOLZEN
57	25670008/0	4	RONDELLA	WASHER	RONDELLE	SCHEIBE
58	12156602/0	2	DADO	NUT	ECROU	MUTTER
59	12794980/0	2	VITE	SCREW	VIS	SCHRAUBE
60	12295200/0	2	DADO	NUT	ECROU	MUTTER
61	25510050/0	2	PERNO	PIN	PIVOT	BOLZEN
62	12523100/0	2	RONDELLA	WASHER	RONDELLE	SCHEIBE
63	24487998/0	2	COPPIGLIA	COTTER PIN	GOUPILLE	SPLIT
64	25430218/0	1	MOLLA	SPRING	RESSORT	FEDER
66	12293200/0	2	DADO	NUT	ECROU	MUTTER

TC ...

TCP ...

TCR ...

TC ... hy.

TCP ... hy.

TCR ... hy.

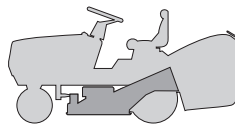

PIATTO DI TAGLIO (1)

CUTTING PLATE (1)

PLATEAU DE COUPE (1)

SCHNEIDWERKZEUG (1)

2001

008.0

1 / 2

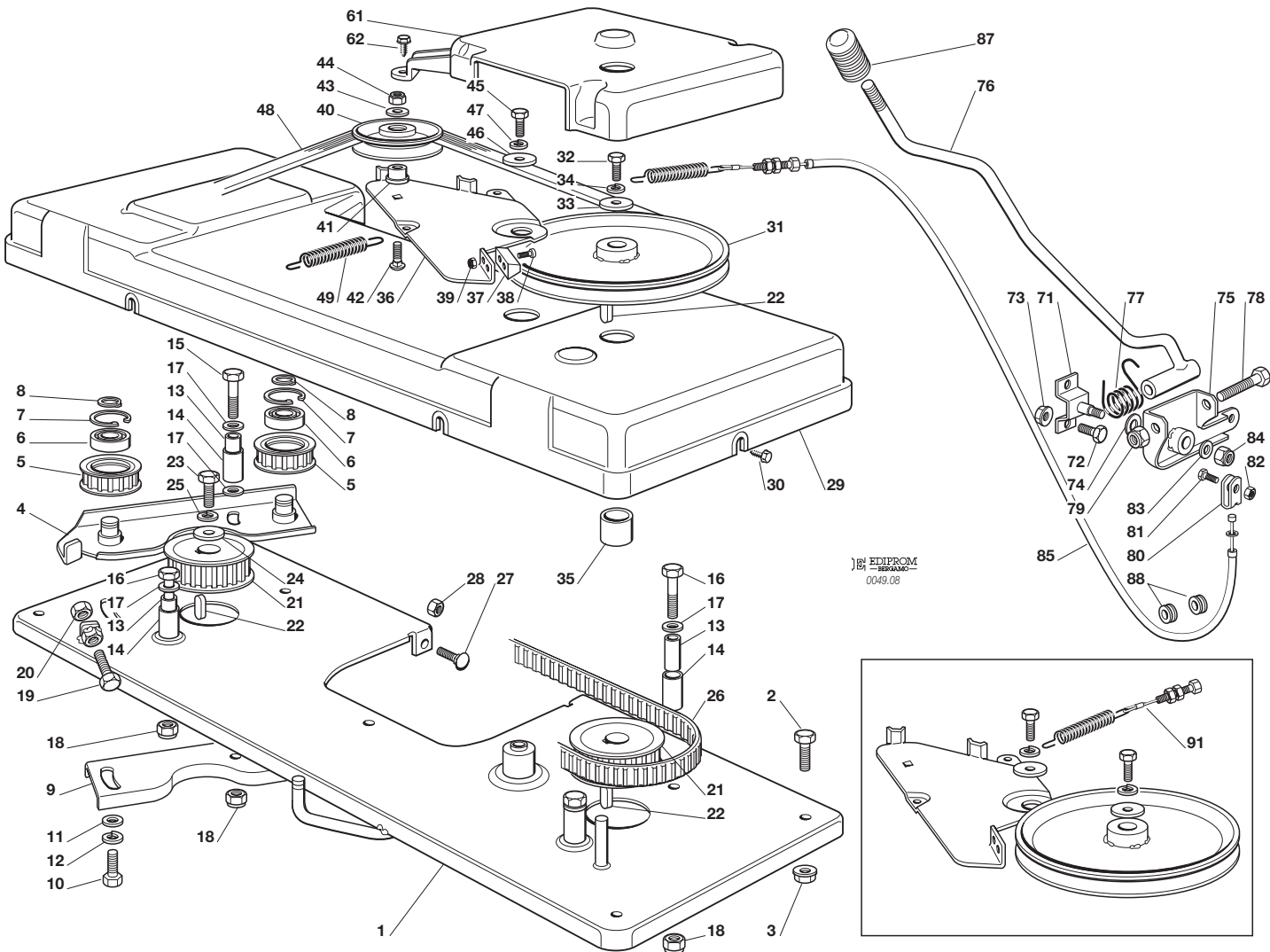

EDIPROM
-BREMBO-
0049.08

N.	CODE	Q.TY	DESCRIZIONE	DESCRIPTION	DESCRIPTION	BESCHREIBUNG
----	------	------	-------------	-------------	-------------	--------------

1	82547003/2	1	PIASTRA (mod. 102)	PLATE (mod. 102)	PLATE (mod. 102)	PLATTE (mod. 102)
	82547005/1	1	PIASTRA (mod. 122)	PLATE (mod. 122)	PLATE (mod. 122)	PLATTE (mod. 122)
2	12792611/0	4	VITE	SCREW	VIS	SCHRAUBE
3	12293201/0	4	DADO	NUT	ECROU	MUTTER
4	82785084/1	1	SUPPORTO	SUPPORT	SUPPORT	HALTERSATZ
5	25601559/1	2	PULEGGIA (mod. 102)	PULLEY (mod. 102)	POULIE (mod. 102)	RIEMENSCHLEIBE (mod. 102)
	25601561/0	2	PULEGGIA (mod. 122)	PULLEY (mod. 122)	POULIE (mod. 122)	RIEMENSCHLEIBE (mod. 122)
6	19216033/1	2	CUSCINETTO	BEARING	ROULEMENT	KUEGELLAGER
7	12610800/0	2	SEEGER	SEEGER	SEEGER	SEEGER
8	12609200/0	2	SEEGER	SEEGER	SEEGER	SEEGER
9	25650037/0	1	RINFORZO	STIFFENING	REINFORCEMENT	VERSTAERKUNG
10	12793102/0	2	VITE	SCREW	VIS	SCHRAUBE
11	12521350/0	2	RONDELLA	WASHER	RONDELLE	SCHEIBE
12	12583500/0	2	GROWER	GROWER	GROWER	GROWER
13	25160003/0	4	DISTANZIALE	SPACER	ENTRETOISE	DISTANZRING
14	25038000/0	4	BOCCOLA	BUSHING	DOUILLE	BUCHSE
15	12691700/0	1	VITE	SCREW	VIS	SCHRAUBE
16	12691200/0	3	VITE	SCREW	VIS	SCHRAUBE
17	12521350/0	5	RONDELLA	WASHER	RONDELLE	SCHEIBE
18	12155000/0	4	DADO	NUT	ECROU	MUTTER
19	12793900/0	1	VITE	SCREW	VIS	SCHRAUBE
20	12293200/0	1	DADO	NUT	ECROU	MUTTER
21	25601560/0	2	PULEGGIA (mod. 102)	PULLEY (mod. 102)	POULIE (mod. 102)	RIEMENSCHLEIBE (mod. 102)
	25601562/0	2	PULEGGIA (mod. 122)	PULLEY (mod. 122)	POULIE (mod. 122)	RIEMENSCHLEIBE (mod. 122)
22	12139480/0	3	CHIAVETTA	KEY	CLAVETTE	KEIL
23	12793102/0	1	VITE	SCREW	VIS	SCHRAUBE
24	25670007/0	1	RONDELLA	WASHER	RONDELLE	SCHEIBE
25	12583500/0	1	GROWER	GROWER	GROWER	GROWER



N.	CODE	Q.TY	DESCRIZIONE	DESCRIPTION	DESCRIPTION	BESCHREIBUNG
26	35065600/0	1	CINGHIA (mod. 102)	BELT (mod. 102)	COURROIRE (mod. 102)	KEILRIEMEN (mod. 102)
	35065601/0	1	CINGHIA (mod. 122)	BELT (mod. 122)	COURROIRE (mod. 122)	KEILRIEMEN (mod. 122)
27	12815200/0	3	VITE	SCREW	VIS	SCHRAUBE
28	12292102/0	3	DADO	NUT	ECROU	MUTTER
29	25060100/2	1	CARTER (mod. 102)	CASE (mod. 102)	CARTER (mod. 102)	BLECH (mod. 102)
	25060101/1	1	CARTER (mod. 122)	CASE (mod. 122)	CARTER (mod. 122)	BLECH (mod. 122)
30	12735110/0	6	VITE	SCREW	VIS	SCHRAUBE
31	25601550/0	1	PULEGGIA (mod. 102)	PULLEY (mod. 102)	POULIE (mod. 102)	RIEMENSCHIEBE (mod. 102)
	25601549/0	1	PULEGGIA (mod. 122)	PULLEY (mod. 122)	POULIE (mod. 122)	RIEMENSCHIEBE (mod. 122)
32	12793102/0	1	VITE	SCREW	VIS	SCHRAUBE
33	25670007/0	1	RONDELLA	WASHER	RONDELLE	SCHEIBE
34	12583500/0	1	GROWER	GROWER	GROWER	GROWER
35	25160002/0	1	DISTANZIALE	SPACER	ENTRETOISE	DISTANRING
36	25318115/1	1	LEVA FRENO (mod. 102)	BRAKE LEVER (mod. 102)	LEVIER FREIN (mod. 102)	BREMSHEBEL (mod. 102)
	25318119/0	1	LEVA FRENO (mod. 122)	BRAKE LEVER (mod. 122)	LEVIER FREIN (mod. 122)	BREMSHEBEL (mod. 122)
40	25601555/0	1	PULEGGIA	PULLEY	POULIE	RIEMENSCHIEBE
41	25160007/0	1	DISTANZIALE	SPACER	ENTRETOISE	DISTANZRING
42	12818900/0	1	VITE	SCREW	VIS	SCHRAUBE
43	12523060/0	1	RONDELLA	WASHER	RONDELLE	SCHEIBE
44	12155000/0	1	DADO	NUT	ECROU	MUTTER
45	12793102/0	1	VITE	SCREW	VIS	SCHRAUBE
46	12523070/0	1	RONDELLA	WASHER	RONDELLE	SCHEIBE
47	12583500/0	1	GROWER	GROWER	GROWER	GROWER
61	25600049/0	1	PROTEZIONE (mod. 102)	GUARD (mod. 102)	PROTECTION (mod. 102)	SCHUTZ (mod. 102)
	25600050/0	1	PROTEZIONE (mod. 122)	GUARD (mod. 122)	PROTECTION (mod. 122)	SCHUTZ (mod. 122)
62	12735402/0	3	VITE	SCREW	VIS	SCHRAUBE

Nei modelli con innesto delle lame a leva:

For models with engagement of the blades by lever:

Dans les modèles avec embrayage des lames à levier:

Bei Modellen mit Hebelschaltung der Messer:

37	25207000/1	1	FERODO	LINING	PASTILLE FREIN	BREMSBELAG
38	12771400/0	2	VITE	SCREW	VIS	SCHRAUBE
39	12154330/0	2	DADO	NUT	ECROU	MUTTER
48	35062813/0	1	CINGHIA (mod. 102)	BELT (mod. 102)	COURROIE (mod. 102)	KEIL RIEMEN (mod. 102)
	35062814/0	1	CINGHIA (mod. 122)	BELT (mod. 122)	COURROIE (mod. 122)	KEIL RIEMEN (mod. 122)
49	25430210/0	1	MOLLA (mod. 102)	SPRING (mod. 102)	RESSORT (mod. 102)	FEDER (mod. 102)
	25430220/0	1	MOLLA (mod. 122)	SPRING (mod. 122)	RESSORT (mod. 122)	FEDER (mod. 122)
71	82774227/0	1	SUPPORTO	SUPPORT	SUPPORT	HALTER
72	12792611/0	2	VITE	SCREW	VIS	SCHRAUBE
73	12293201/0	2	DADO	NUT	ECROU	MUTTER
74	22672151/0	1	RONDELLA	WASHER	RONDELLE	SCHEIBE
75	82774229/0	1	STAFFA	CLAMP	BRIDE	BRIDE
76	82318177/0	1	LEVA	LEVER	LEVIER	HEBEL
77	25430227/0	1	MOLLA	SPRING	RESSORT	FEDER
78	12692050/0	1	VITE	SCREW	VIS	SCHRAUBE
79	12155000/0	1	DADO	NUT	ECROU	MUTTER
80	22061337/0	1	CAVALLOTTO	CONNECTING PLATE	PAQUE DE CONNEXION	BUGEL BOLZEN
81	12791213/0	1	VITE	SCREW	VIS	SCHRAUBE
82	12154510/0	1	DADO	NUT	ECROU	MUTTER
83	12523060/0	1	RONDELLA	WASHER	RONDELLE	SCHEIBE
84	12155010/0	1	DADO	NUT	ECROU	MUTTER
85	82004606/0	1	FILO (mod. 102)	WIRE (mod. 102)	FIL (mod. 102)	KABEL (mod. 102)
	82004607/0	1	FILO (mod. 122)	WIRE (mod. 122)	FIL (mod. 122)	KABEL (mod. 122)
87	25394510/0	1	MANOPOLA	KNOB	POIGNEE	GRIFF
88	18564514/2	2	PASSACAVO	FAIR LEAD	PASSE CABLE	KABELDURCHGANG

Nei modelli con innesto delle lame elettromagnetico:

For models with engagement of the blades by electromagnetic clutch:

Dans les modèles avec embrayage des lames électromagnétique:

Bei Modellen mit elektromagnetischer Schaltung der Messer:

48	35062811/0	1	CINGHIA (mod. 102)	BELT (mod. 102)	COURROIE (mod. 102)	KEIL RIEMEN (mod. 102)
	35062812/0	1	CINGHIA (mod. 122)	BELT (mod. 122)	COURROIE (mod. 122)	KEIL RIEMEN (mod. 122)
91	82004608/0	1	FILO (mod. 102)	WIRE (mod. 102)	FIL (mod. 102)	KABEL (mod. 102)
	82004609/0	1	FILO (mod. 122)	WIRE (mod. 122)	FIL (mod. 122)	KABEL (mod. 122)

TC ...

TCP ...

TCR ...

TC ... hy.

TCP ... hy.

TCR ... hy.

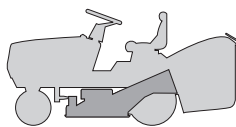

PIATTO DI TAGLIO (2)

CUTTING PLATE (2)

PLATEAU DE COUPE (2)

SCHNEIDWERKZEUG (2)

2001

009.0

1 / 2

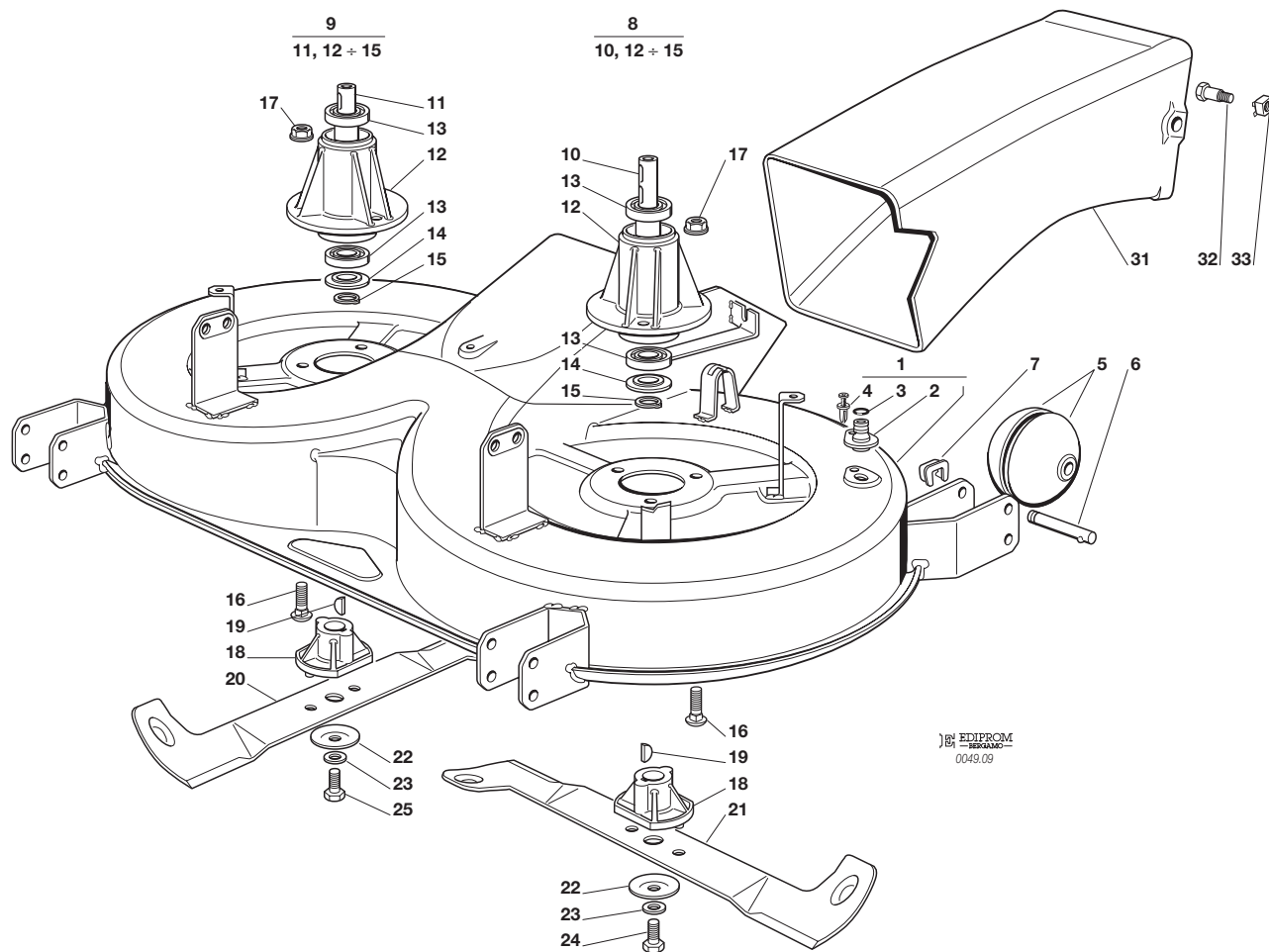
 EDIPROM
 0049.09

N.	CODE	Q.TY	DESCRIZIONE	DESCRIPTION	DESCRIPTION	BESCHREIBUNG
1	82565010/0	1	ASSIEME PIATTO DI TAGLIO (CON 2 - 3 - 4) (mod. 102)	CUTTING PLATE ASS.Y (WITH 2 - 3 - 4) (mod. 102)	ENS. PATEAU DE COUPE (AVEC 2 - 3 - 4) (mod. 102)	SCHNEIDWERKZEUG (MIT 2 - 3 - 4) (mod. 102)
	82565011/0	1	ASSIEME PIATTO DI TAGLIO (CON 2 - 3 - 4) (mod. 122)	CUTTING PLATE ASS.Y (WITH 2 - 3 - 4) (mod. 122)	ENS. PATEAU DE COUPE (AVEC 2 - 3 - 4) (mod. 122)	SCHNEIDWERKZEUG (MIT 2 - 3 - 4) (mod. 122)
2	25033060/0	2	ATTACCO TUBO ACQUA	WATER HOSE CONNECTION	RACCORD TUYAU D'EAU	WASSERANSCHLUSS
3	19035000/0	2	ANELLO OR	O RING	O RING	O RING
4	12500030/0	2	RIVETTO	RIVET	RIVET	NIET
5	82700000/0	4	RUOTINO ANTISCALPO	LEVELLING SMALL WHEEL	ROULETTES ANTISCALP	EBENUNGRAEDCHEN
6	25510006/0	4	PERNO	PIN	PIVOT	BOLZEN
7	12436030/0	4	PIASTRINA	PLATE	PLAQUE	PLATTE
8	82207200/1	1	ASS. FLANGIA ALBERO PRINCIPALE (10, 12÷15)	BLADE MAIN SHAFT SUPPORT (10, 12÷15)	SUPPORT ARBRE LAME PRINCIPAL (10, 12÷15)	MASSERWELLEHAPT- SATZ (10, 12÷15)
9	82207201/2	1	ASS. FLANGIA ALBERO SECONDARIO (11, 12÷15)	BLADE SECONDARY SHAFT SUPPORT (11, 12÷15)	SUPPORT ARBRE LAME SECONDAIRE (11, 12÷15)	MASSERWELLE ZWEITER- SATZ (11, 12÷15)
10	25020800/1	1	ALBERO LAMA PRINCIPALE	MAIN BLADE SHAFT	ARBRE LAME PRINCIPAL	HAUP MESSERWELLE
11	25020801/2	1	ALBERO LAMA SECONDARIO	SECONDARY BLADE SHAFT	ARBRE LAME SECONDAIRE	ZWEITE MESSERWELLE
12	25207200/0	2	FLANGIA ALBERO LAMA	BLADE SHAFT SUPPORT	SUPPORT ARBRE LAME	MESSERWELLE
13	19216032/0	4	CUSCINETTO	BEARING	ROULEMENT	KUEGELLAGER
14	25160501/0	2	DISCO PARAPOLVERE	DUST COVER	PROTEGE-POUSSIERE	STAUBSCHUTTSCHIEBE
15	12609260/0	2	SEEGER	SEEGER	SEEGER	SEEGER
16	12818700/0	6	VITE	SCREW	VIS	SCHRAUBE
17	12154210/0	6	DADO	NUT	ECROU	MUTTER
18	25463200/0	2	MOZZO COLTELLO	BLADE HUB	MOYEU LAME	MESSERHALTER
19	12139100/0	2	LINGUETTA	KEY	CLAVETTE	KEIL
20	82004341/1	1	COLTELLO DX (mod. 102)	RIGHT BLADE (mod. 102)	LAME DROITE (mod. 102)	RECHTER MESSER (mod. 102)
	82004343/0	1	COLTELLO DX (mod. 122)	RIGHT BLADE (mod. 122)	LAME DROITE (mod. 122)	RECHTER MESSER (mod. 122)
21	82004340/1	1	COLTELLO SX (mod. 102)	LEFT BLADE (mod. 102)	LAME GAUCHE (mod. 102)	LINKER MESSER (mod. 102)
	82004342/0	1	COLTELLO SX (mod. 122)	LEFT BLADE (mod. 122)	LAME GAUCHE (mod. 122)	LINKER MESSER (mod. 122)
22	22160400/0	2	DISCO ELASTICO	ELASTIC WASHER	RONDELLE ELASTIQUE	FEDERSCHIEBE
23	12523080/0	2	RONDELLA	WASHER	RONDELLE	SCHEIBE
24	12735694/0	1	VITE	SCREW	VIS	SCHRAUBE



N.	CODE	Q.TY	DESCRIZIONE	DESCRIPTION	DESCRIPTION	BESCHREIBUNG
25	12735695/1	1	VITE	SCREW	VIS	SCHRAUBE
31	25108009/0	1	CONVOGLIATORE POSTER.	REAR CONVEYOR ASS.Y	ENS. CONVOYEUR POST.	HINTERLEITBLECHSATZ
32	25510051/0	2	VITE	SCREW	VIS	SCHRAUBE
33	12360425/0	2	DADO	NUT	ECROU	MUTTER

Nei modelli con innesto delle lame a leva:

For models with engagement of the blades by lever:

Dans les modèles avec embrayage des lames à levier:

Bei Modellen mit Hebelschaltung der Messer:

—	82565015/1	1	PIATTO DI TAGLIO ASSEMBLATO (mod. 102) (008, 1÷62 + 009, 1÷25)	CUTTING PLATE, ASSEMBLED (mod. 102) (008, 1÷62 + 009, 1÷25)	PLATEAU DE COUPE, COMPLETE (mod. 102) (008, 1÷62 + 009, 1÷25)	CHNEIDWERKZEUG, KOMPLETT (mod. 102) (008, 1÷62 + 009, 1÷25)
—	82565016/0	1	PIATTO DI TAGLIO ASSEMBLATO (mod. 122) (008, 1÷62 + 009, 1÷25)	CUTTING PLATE, ASSEMBLED (mod. 122) (008, 1÷62 + 009, 1÷25)	PLATEAU DE COUPE, COMPLETE (mod. 122) (008, 1÷62 + 009, 1÷25)	CHNEIDWERKZEUG, KOMPLETT (mod. 122) (008, 1÷62 + 009, 1÷25)

Nei modelli con innesto delle lame elettromagnetico:

For models with engagement of the blades by electromagnetic clutch:

Dans les modèles avec embrayage des lames électromagnétique:

Bei Modellen mit elektromagnetischer Schaltung der Messer:

—	82565020/1	1	PIATTO DI TAGLIO ASSEMBLATO (mod. 102) (008, 1÷62 + 009, 1÷25)	CUTTING PLATE, ASSEMBLED (mod. 102) (008, 1÷62 + 009, 1÷25)	PLATEAU DE COUPE, COMPLETE (mod. 102) (008, 1÷62 + 009, 1÷25)	CHNEIDWERKZEUG, KOMPLETT (mod. 102) (008, 1÷62 + 009, 1÷25)
—	82565021/0	1	PIATTO DI TAGLIO ASSEMBLATO (mod. 122) (008, 1÷62 + 009, 1÷25)	CUTTING PLATE, ASSEMBLED (mod. 122) (008, 1÷62 + 009, 1÷25)	PLATEAU DE COUPE, COMPLETE (mod. 122) (008, 1÷62 + 009, 1÷25)	CHNEIDWERKZEUG, KOMPLETT (mod. 122) (008, 1÷62 + 009, 1÷25)

TC ...

TCP ...

TCR ...

TC ... hy.

TCP ... hy.

TCR ... hy.

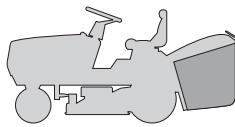

**SACCO
GRASSCATCHER
BAC
AUFFANGSACK**

2001

010.0

1 / 1

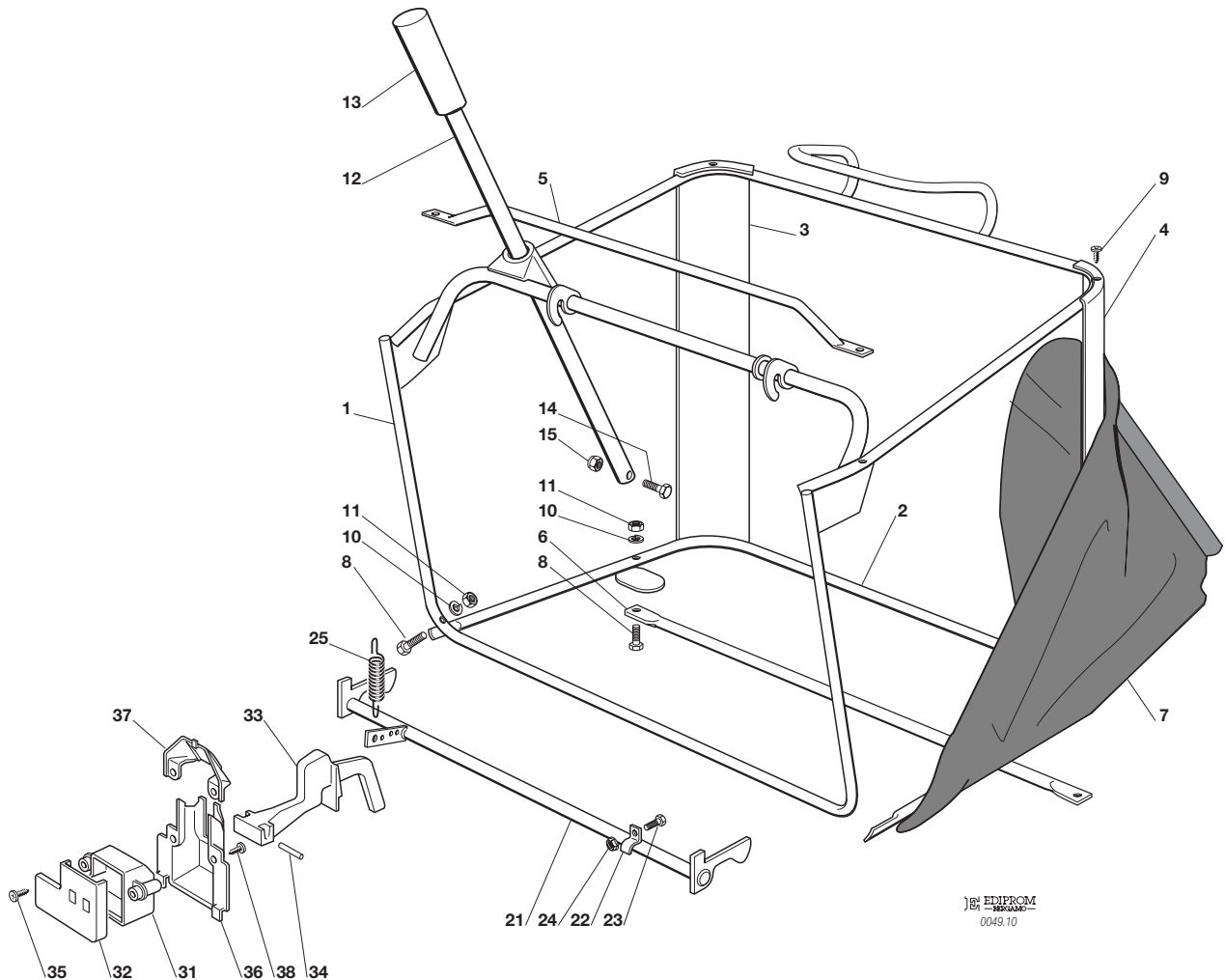

EDIPROM
-REPARAZIONE-
0049.10

N.	CODE	Q.TY	DESCRIZIONE	DESCRIPTION	DESCRIPTION	BESCHREIBUNG
1	82800051/0	1	TELAIO SUPERIORE	UPPER FRAME	CHASSIS SUPERIEUR	OBERERRAHMEN
2	82800002/2	1	TELAIO INFERIORE	LOWER FRAME	CHASSIS INFERIEUR	UNTERERRAHMEN
3	25032001/1	1	ANGOLARE DESTRO	RIGHT ANGULAR SUPPORT	SUPPORT ANG. DROITE	RECHTER HALTER
4	25032002/1	1	ANGOLARE SINISTRO	LEFT ANGULAR SUPPORT	SUPPORT ANG. GAUCHE	LINKER HALTER
5	82394001/1	1	MANIGLIA ANTERIORE	FRONT HANDLE	POIGNEE ANTERIEURE	VORDERGRIFF
6	82650038/0	1	RINFORZO INFERIORE	LOWER STIFFENING	RENFORCEMENT SUPER.	OBERE VERSTAERKUNG
7	82106000/2	1	SACCO	GRASSCATCHER	SAC	SACK
8	12792099/0	4	VITE	SCREW	VIS	SCHRAUBE
9	12729601/0	4	VITE	SCREW	VIS	SCHRAUBE
10	12582101/0	4	GROWER	GROWER	GROWER	GROWER
11	12292100/0	4	DADO	NUT	ECROU	MUTTER
12	25869029/1	1	TUBO	ROD	TIGE	STANGE
13	25394508/0	1	MANOPOLA	HANDLE	POINGEE	GRIFF
14	12792099/0	1	VITE	SCREW	VIS	SCHRAUBE
15	12154510/0	1	DADO	NUT	ECROU	MUTTER
21	82000483/0	1	ASTA AGGANCIO SACCO	COUPLING ROD	TIGE D'ACCROCHAGE	KUPPLUNGSTANGE
22	25774220/0	2	STAFFA ANCORAGGIO	ANCHOR BRACKET	ETRIER	BRIDE
23	12791200/0	2	VITE	SCREW	VIS	SCHRAUBE
24	12292102/0	2	DADO	NUT	ECROU	MUTTER
25	25430210/0	1	MOLLA	SPRING	RESSORT	FEDER
31	25600041/0	1	PROTEZIONE MICRO	MICRO PROTECTION	PROTECTION MICRO	SCHUTZ
32	25600042/0	1	COPERCHIO PROTEZIONE	PROTECTION COVER	COUVERCLE PROTECTION	SCHUTZDEKEL
33	25318124/0	1	LEVA	LEVER	LEVIER	HEBEL
34	12400030/0	1	SPINA	PIN	GOUPILLE	STIFT
35	12728510/0	1	VITE	SCREW	VIS	SCHRAUBE
36	25600047/0	1	PROTEZIONE MICRO	MICRO PROTECTION	PROTECTION MICRO	SCHUTZ
37	25600048/0	1	COPERCHIO PROTEZIONE	PROTECTION COVER	COUVERCLE PROTECTION	SCHUTZDEKEL
38	12728450/0	2	VITE	SCREW	VIS	SCHRAUBE

TC ...

TCP ...

TCR ...

TC ... hy.

TCP ... hy.

TCR ... hy.

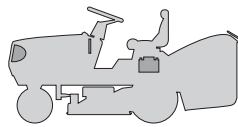

PARTI ELETTRICHE
ELECTRICAL PARTS
PARTIES ELECTRIQUES
ELETRISCHETEILE

2001

011Y.0

1 / 2

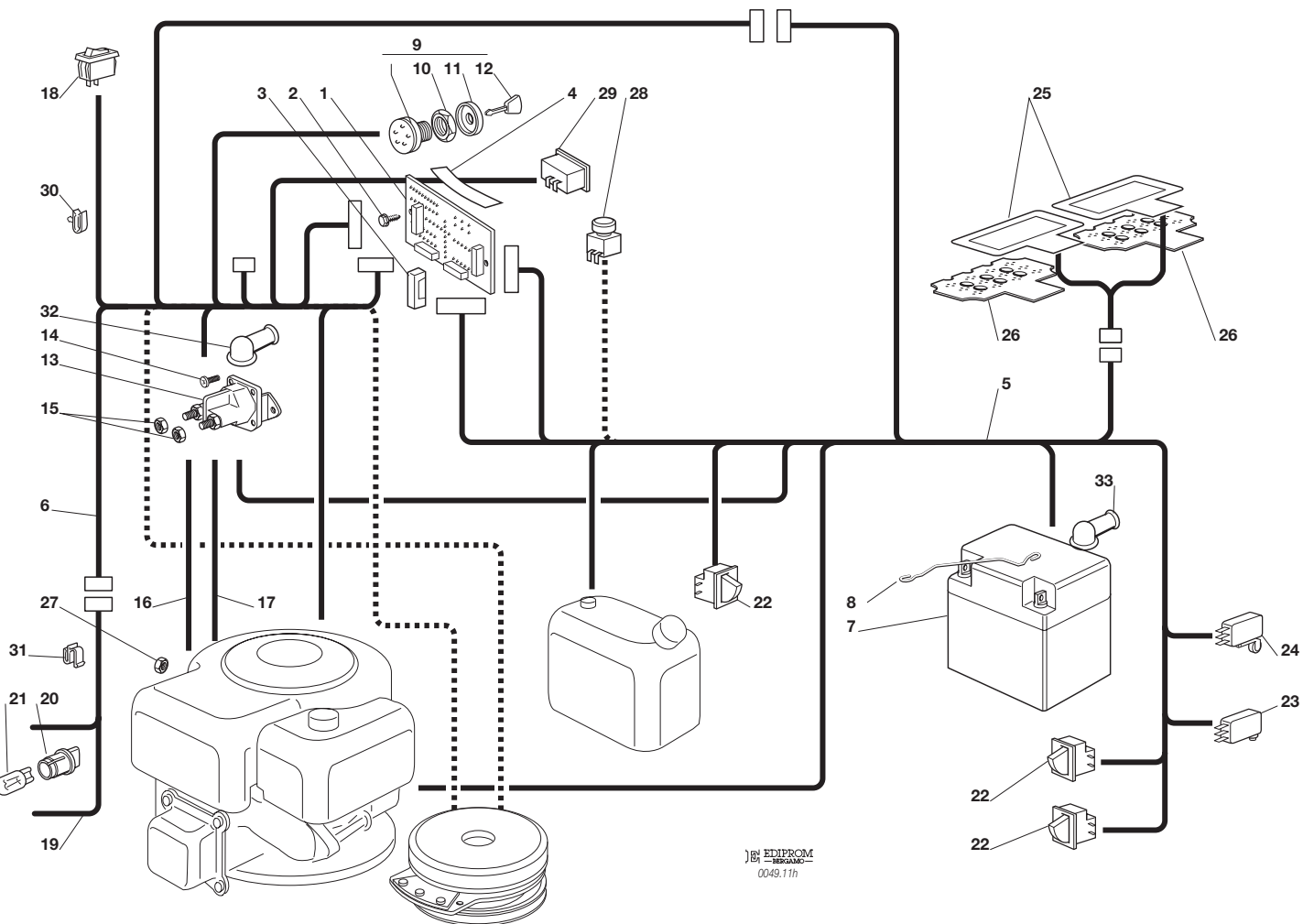

EDIPROM
REGGANO
0049.11h

N.	CODE	Q.TY	DESCRIZIONE	DESCRIPTION	DESCRIPTION	BESCHREIBUNG
2	12735105/0	3	VITE	SCREW	VIS	SCHRAUBE
3	33340033/0	1	FUSIBILE	FUSE	FUSIBLE	SICHERUNG
4	25420004/0	1	MEMBRANA (6 FUNZIONI)	CHECK CONTROL (6 FUNCTIONS)	PANNEAU DE CONTROLE (6 INDICATIONS)	KONTROLLTAFEL (6 ANGABEN)
	25420005/0	1	MEMBRANA (8 FUNZIONI)	CHECK CONTROL (8 FUNCTIONS)	PANNEAU DE CONTROLE (8 INDICATIONS)	KONTROLLTAFEL (8 ANGABEN)
5	82040093/0	1	CABLAGGIO POSTERIORE 12,5 - 13 HP B&S	CABLES ASS.Y 12,5 - 13 HP B&S	ENS. CABLAGES 12,5 - 13 HP B&S	KABELSATZ 12,5 - 13 HP B&S
	82040095/0		13 - 15 HP TECUMSEH	13 - 15 HP TECUMSEH	13 - 15 HP TECUMSEH	13 - 15 HP TECUMSEH
	82040094/0		15 - 15,5 - 17 HP B&S	15 - 15,5 - 17 HP B&S	15 - 15,5 - 17 HP B&S	15 - 15,5 - 17 HP B&S
	82040094/0		18 - 20 HP B&S	18 - 20 HP B&S	18 - 20 HP B&S	18 - 20 HP B&S
6	82040087/0	1	CABLAGGIO ANTERIORE 12,5 - 13 HP B&S (senza contaore)	CABLES ASS.Y 12,5 - 13 HP B&S (without hour counter)	ENS. CABLAGES 12,5 - 13 HP B&S (sans compte-heurs)	KABELSATZ 12,5 - 13 HP B&S (ohne betriebsstundenzähler)
	82040088/0		13 - 15 HP TECUMSEH	13 - 15 HP TECUMSEH	13 - 15 HP TECUMSEH	13 - 15 HP TECUMSEH
	82040088/0		12,5 - 13 HP B&S (con contaore)	12,5 - 13 HP B&S (with hour counter)	12,5 - 13 HP B&S (avec compte-heurs)	12,5 - 13 HP B&S (mit betriebsstundenzähler)
	82040089/0		15 - 15,5 - 17 HP B&S	15 - 15,5 - 17 HP B&S	15 - 15,5 - 17 HP B&S	15 - 15,5 - 17 HP B&S
	82040089/0		18 - 20 HP B&S	18 - 20 HP B&S	18 - 20 HP B&S	18 - 20 HP B&S
7	18120002/1	1	BATTERIA	BATTERY	BATTERIE	BATTERIE
8	25430230/0	1	MOLLA	SPRING	RESSORT	FEDER
9	18450065/1	1	INTERRUTTORE AVVIAM.	STARTING SWITCH	INTERRUPTEUR DEMARR.	SCHALTER
10	18400861/0	1	GHIERA	RINGNUT	EMBOUT	NUTMUTTER
11	18565351/0	1	PROTEZIONE GHIERA	RINGNUT PROTECTION	PROTECTION EMBOUT	NUTMUTTER SCHUTZ
12	18210016/0	1	CHIAVE AVVIAMENTO	STARTING KEY	CLEF A DEMARRAGE	SCHLÜSSEL FÜR START
13	18736110/0	1	RELÉ AVVIAMENTO	STARTER RELAY	RELAIS D'ALLUMAGE	ANLASSRELAIS
14	12791213/0	2	VITE	SCREW	VIS	SCHRAUBE
15	12360352/0	2	DADO	NUT	ECROU	MUTTER
16	25065002/0	1	CAVO SOLEN. AVV.	CABLES ASS.Y	ENS. CABLAGES	KABELSATZ
17	25065003/0	1	CAVO RICARICA	CABLE	CABLES	KABEL
18	18450060/1	1	INTERRUTTORE	FARILAMP SWITCH	INTERRUPTEUR PHARES	LICHTEN SCHALTER



N.	CODE	Q.TY	DESCRIZIONE	DESCRIPTION	DESCRIPTION	BESCHREIBUNG
19	82040063/0	1	CABLAGGIO LAMPADE	CABLE	CABLES	KABEL
20	33500030/0	2	PORTALAMPADE	LAMP HOLDER	DOUILLE DE LAMPE	SCHEINWERFERLAMPE
21	18459100/0	2	LAMPADA	FARILAMP FOR LIGHTS	LAMPE POUR PHARES	LAMPENFASSUN
23	19410605/1	1	MICRO SACCO PIENO	FULL GRASSCAT. MICROSW.	MICRO BAC PLEIN	VOLLKORB VORRICHTUNG
24	19410609/0	1	MICRO FOLLE	NEUTRAL SWITCH	MICROINT. POINT MORT	LEERLAUF MIKROSCHALTER
25	25420040/0	1	COPPIA MEMBRANE	MEMBRANE	MEMBRANE	MEMBRAN
26	25600055/0	2	PIASTRINA	PLATE	PLAQUE	PLATTE
27	12361005/0	1	DADO	NUT	ECROU	MUTTER
29	18230000/0	1	CONTAORE	HOOR COUNTER	COMPTE-HEURS	BETRIEBSSTUNDEZÄHLER
30	33320506/0	5	FERMACAVO	FAIRLED	FIXATION CABLE	KABELBEFESTIGUNG
31	33320504/0	1	FERMACAVO	FAIRLED	FIXATION CABLE	KABELBEFESTIGUNG
32	18564861/0	1	CAPPUCCIO	PROTECTION	CAPUCHON	STECKER
33	18564864/0	1	CAPPUCCIO	PROTECTION	CAPUCHON	STECKER

**Nei modelli con innesto
delle lame a leva:**

**For models with
engagement of the blades
by lever:**

**Dans les modèles avec
embrayage des lames
à levier:**

**Bei Modellen mit
Hebelschaltung der Messer:**

1	27522412/0	1	SCHEDA ELETTRONICA	ELECTRONIC CARD	CARTE ELECTRONIQUE	ELEKTRONISCHE KARTE
22	19410606/0	3	MICRO INTERRUPTORE	MICRO	MICRO	MIKRO

**Nei modelli con innesto
delle lame
elettromagnetico:**

**For models with
engagement of the blades
by electromagnetic clutch:**

**Dans les modèles avec
embrayage des lames
électromagnétique:**

**Bei Modellen mit
elektromagnetischer
Schaltung der Messer:**

1	27522413/0	1	SCHEDA ELETTRONICA	ELECTRONIC CARD	CARTE ELECTRONIQUE	ELEKTRONISCHE KARTE
22	19410606/0	2	MICRO INTERRUPTORE	MICRO	MICRO	MIKRO
28	18450067/0	1	INTERRUPTORE FRIZIONE	CLUTCH SWITCH	INTERRUPTEUR EMBRAJAGE	KUPPLUNG SCHALTER

TC ...

TCP ...

TCR ...

TC ... hy.

TCP ... hy.

TCR ... hy.

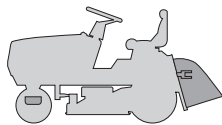

ACCESSORI A RICHIESTA
OPTIONALS ON REQUEST
ACCESSOIRES SUR DEMANDE
ZUBEHOERE NACH ANFRAGE

2001

012.0

1 / 1

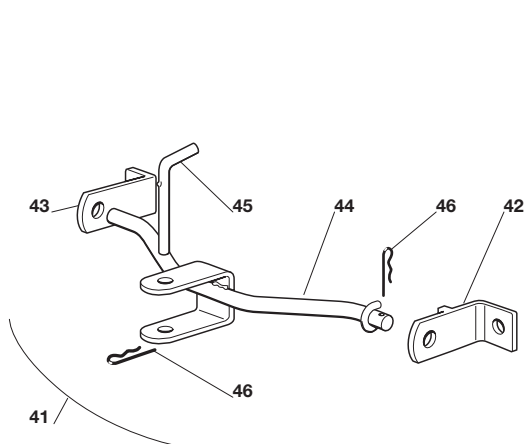

EDIPROM
0049.12

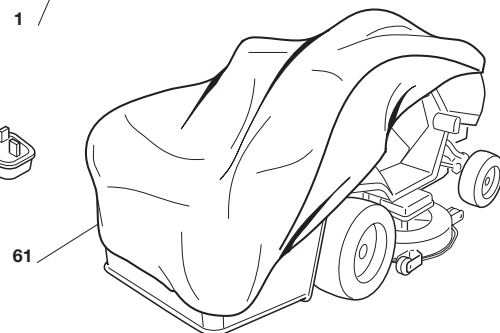
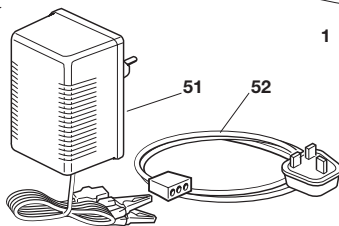
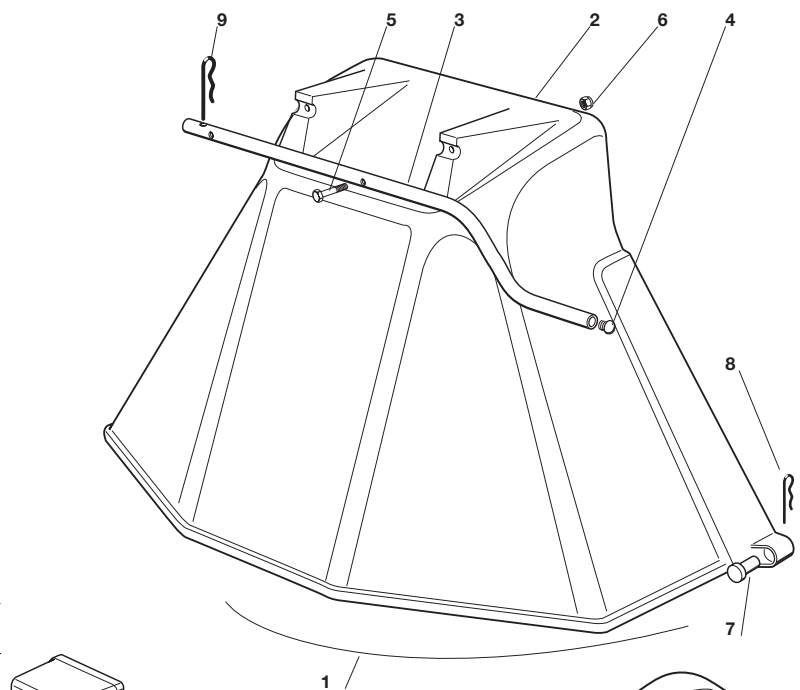
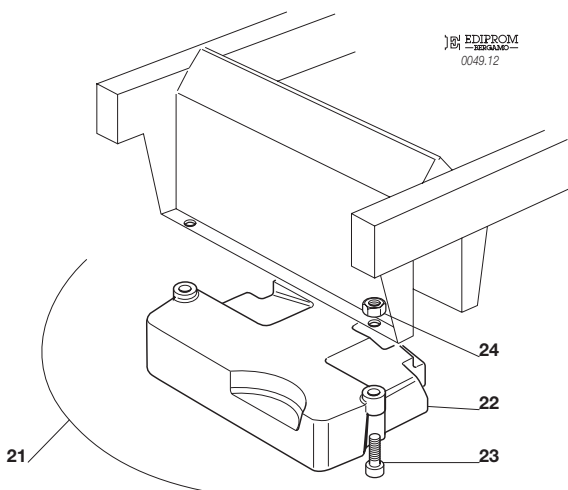

N.	CODE	Q.TY	DESCRIZIONE	DESCRIPTION	DESCRIPTION	BESCHREIBUNG
1	99900015/0	1	ASS. KIT PROTEZIONE USCITA	EJECTION-GUARD ASS.Y	KIT PROTECTION SORTIE	VORRICHTUNG FÜR AUSWURFSCHUTZ
2	82400003/0	1	PROTEZIONE USCITA	EJECTION GUARD	PROTECTION SORTIE	AUSWURFSCHUTZ
3	25869043/0	1	TUBO DI AGGANCIO	SUPPORT	SOPPORT	HALTER
4	18566110/0	2	PUNTALE	CAP	BOUCHON	PFROPFEN
5	12689515/0	2	VITE	SCREW	VIS	SCHRAUBE
6	12154510/0	2	DADO	NUT	ECROU	MUTTER
7	25510022/0	2	PERNO	PIN	PIVOT	BOLZEN
8	24487998/0	2	COPPIGLIA	COTTER PIN	GOUPILLE	SPLIT
9	24487999/0	1	COPPIGLIA	COTTER PIN	GOUPILLE	SPLIT
21	99900030/5	1	ASS. KIT PESO ANT.	FRONT WEIGHT KIT	KIT POIDS ANTERIEUR	VORDERGEWICHT VORRICHTUNG
22	25519997/0	1	PESO	WEIGHT	POIDS	GEWICHT
23	12760520/0	3	VITE	SCREW	VIS	SCHRAUBE
24	12155000/0	3	DADO	NUT	ECROU	MUTTER
41	99900005/0	1	ASS. KIT TRAINO	HITCH KIT	KIT DE TRAINAGE	ZUGVORRICHTUNG
42	82735502/0	1	STAFFA SUPPORTO TRAINO DX	BRACKET RIGHT HITCH SUPPORT	ETRIER SUPPORT TRAINAGE DROITE	BUEGEL HALTER FÜR RECHTEN ZUG
43	25774213/0	1	STAFFA SUPPORTO TRAINO SX	BRACKET LEFT HITCH SUPPORT	ETRIER SUPPORT TRAINAGE GAUCHE	BUEGELHALTER FÜR LINKEN ZUG
44	82033105/0	1	BARRA	ROD	BARRE	STANGE
45	25510021/0	1	PERNO	PIN	PIVOT	BOLZEN
46	24487999/0	2	COPPIGLIA	COTTER PIN	GOUPILLE	SPLIT
51	82180050/0	1	CARICA BATTERIE	BATTERY CHARGER	CHARGEUR DE BATTERIES	BATTERIELADEGERÄT
52	82180055/0	1	CAVO (solo per U.K.)	CABLE (U.K. only)	CABLES (seulement U.K.)	KABEL (nur für U.K.)
61	18737950/0	1	TELO DI COPERTURA	CLOTH	BÂCHE	PLANE

TC ...

TCP ...

TCR ...

TC ... hy.

TCP ... hy.

TCR ... hy.

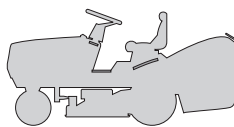

ETICHETTE
LABELS
ETIQUETTES
KLEBZETTEL

2001

013.0

1 / 1

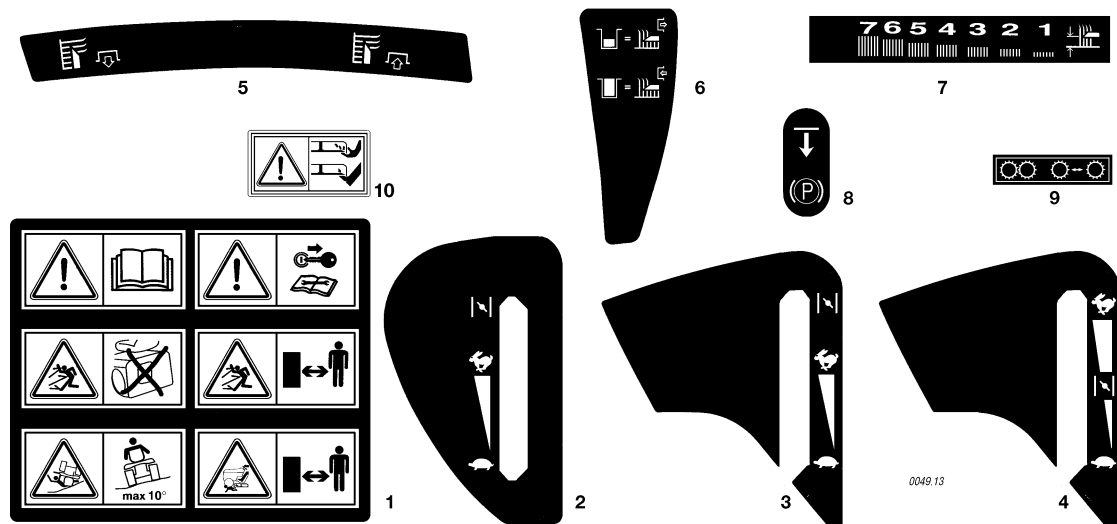

N.	CODE	Q.TY	DESCRIZIONE	DESCRIPTION	DESCRIPTION	BESCHREIBUNG
1	14357190/0	1	ETICHETTA	LABEL	ETIQUETTE	KLEBZETTEL
2	14356754/1	1	ETICHETTA (TCP)	LABEL (TCP)	ETIQUETTE (TCP)	KLEBZETTEL (TCP)
3	14356177/2	1	ETICHETTA (TC - TCR)	LABEL (TC - TCR)	ETIQUETTE (TC - TCR)	KLEBZETTEL (TC - TCR)
4	14357184/2	1	ETICHETTA (TC - TCR)	LABEL (TC - TCR)	ETIQUETTE (TC - TCR)	KLEBZETTEL (TC - TCR)
7	14357905/0	1	ETICHETTA	LABEL	ETIQUETTE	KLEBZETTEL
8	14357526/0	1	ETICHETTA	LABEL	ETIQUETTE	KLEBZETTEL
9	14357423/1	1	ETICHETTA	LABEL	ETIQUETTE	KLEBZETTEL
10	14356699/0	2	ETICHETTA	LABEL	ETIQUETTE	KLEBZETTEL

*Nei modelli con innesto
delle lame a leva:*

*For models with
engagement of the blades
by lever:*

*Dans les modèles avec
embrayage des lames
à levier:*

*Bei Modellen mit
Hebelschaltung der Messer:*

5	14357906/0	1	ETICHETTA	LABEL	ETIQUETTE	KLEBZETTEL
---	------------	---	-----------	-------	-----------	------------

*Nei modelli con innesto
delle lame
elettromagnetico:*

*For models with
engagement of the blades
by electromagnetic clutch:*

*Dans les modèles avec
embrayage des lames
électromagnétique:*

*Bei Modellen mit
elektromagnetischer
Schaltung der Messer:*

6	14357967/0	1	ETICHETTA	LABEL	ETIQUETTE	KLEBZETTEL
---	------------	---	-----------	-------	-----------	------------