

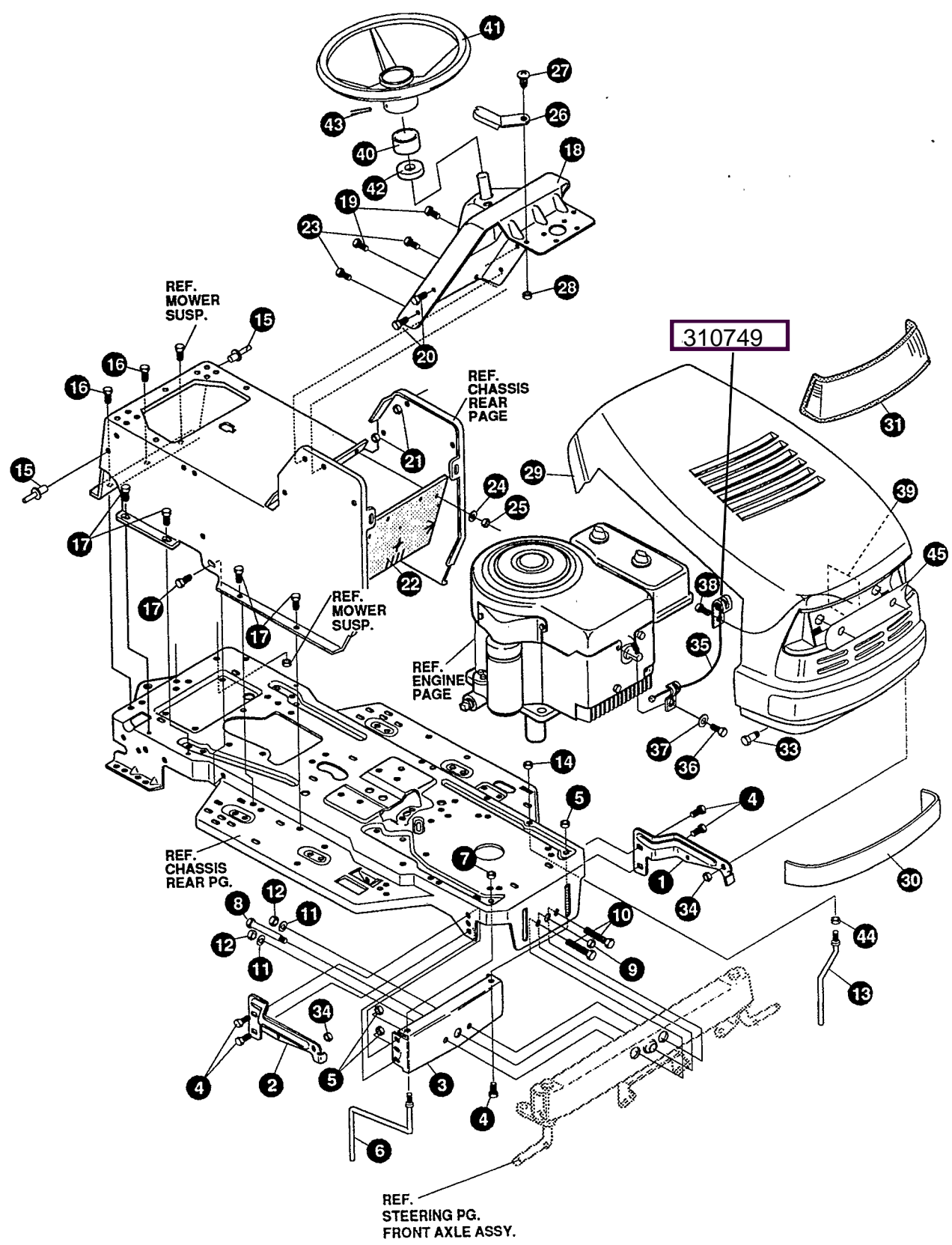

F3560-071 (0)

13HP/40"

Texas 130-40h 1995



NOTE: ALWAYS USE ORIGINAL EQUIPMENT PARTS.
 Use of service/replacement parts other than original equipment parts may void your warranty.

ALL UNNUMBERED ITEMS ARE INTERCHANGEABLE WITH OPPOSITE SIDE

325863 D

KEY#	PART#	DESCRIPTION	QTY
1	302857-853	BRACKET, GRILLE, LH, H-14	1
2	302856-853	BRACKET, GRILLE, RH, H-14	1
3	313541-853	BRACKET, FRONT AXLE	1
4	56030	SCREW, 5/16-18 X .75 WDFLLK	5
5	55273	NUT, 5/16-18 WDFLLKLRG WHIZ	5
6	300440	GUIDE, BELT, RIDER	1
7	1498	NUT, 5/16-18 REGHEXCTRLK	1
8	308207	BOLT, .625 X 2.18 HSH, 1/2-13	1
9	309008	NUT, 1/2-13 HEXJAM CTRLK	1
10	180138	SCREW, 3/8-16 X 3.00 HHC	2
11	2483	WASHER, .39 ID X 1.25 D X .07 BELLVIL	2
12	1499	NUT, 3/8-16 REGHXCTRLK	2
13	300635	GUIDE, BELT SHORT, 15" WHEEL	1
14	124824	NUT, 5/16-18 HEXJAM	1
15	46763	RIVET, POP .187 DIA X .450 LONG	3
16	35497	SCREW, 5/16-18 X .50 WAHTAP	2
17	995346	SCREW, 1/4-20 X .50 WAHTAP	10
18	309447-830	DASH, STEEL, LF, SUSP	1
19	995346	SCREW, 1/4-20 X .50 WAHTAP	2
20	44811	SCREW, 1/4-20 X .75 WAHTAP	4
21	50352	NUT, 1/4-20 WDFLLK, TOPLOCK	4
22	312306	BAFFLE, CONSOLE, SOUND, EXPORT, LF	1
23	44811	SCREW, 1/4-20 X .75 WAHTAP	2
24	120392	WASHER, FLAT .281 X .63 X .065	2
25	1502	NUT, 1/4-20 REGHEXCTRLK	2
26	313021-853	GUIDE, HOOD, SF & LF, H14	2
27	180020	SCREW, 1/4-20 X .75 HHC	2
28	51335	NUT, 1/4-20 WDFLWHIZ-LK	2
29	302674	HOOD, MEDIUM, H-14	1
30	322700	DECAL, TAPE, H14, .8MIL VINYL	1
31	302670	LENS, HEADLAMP	1
33	56676	BOLT, .375 X .580 HSH, 5/16-18	2
34	1498	NUT, 5/16-18 REGHEXCTRLK	2
35	310749	LANYARD, HOOD 9.16 LONG, H14	1
36	180020	SCREW, 1/4-20 X .75 HHC	1
37	120380	WASHER, REGSPTLK .263 X .49 X .07	1
38	49050	SCREW, 1/4-10 X .75 PHPNTAP	1
39	301452	FOIL, HEAT REFLECTOR	1
40	311465	COVER, STEERING SHAFT	1
41	330510	STEERING WHEEL	1
42	301413	SPACER, STEERING SHAFT	1
43	456378	PIN, SPRING .250 DIA X 2.00 LONG	1
44	271190	NUT, 3/8-16 HEXKEPS	1
45	308492	FOIL, LENS, HOOD REFLECTOR	1
	336781	PARTS MANUAL	1
	336049	OPERATOR'S MANUAL (ENGLISH)	1

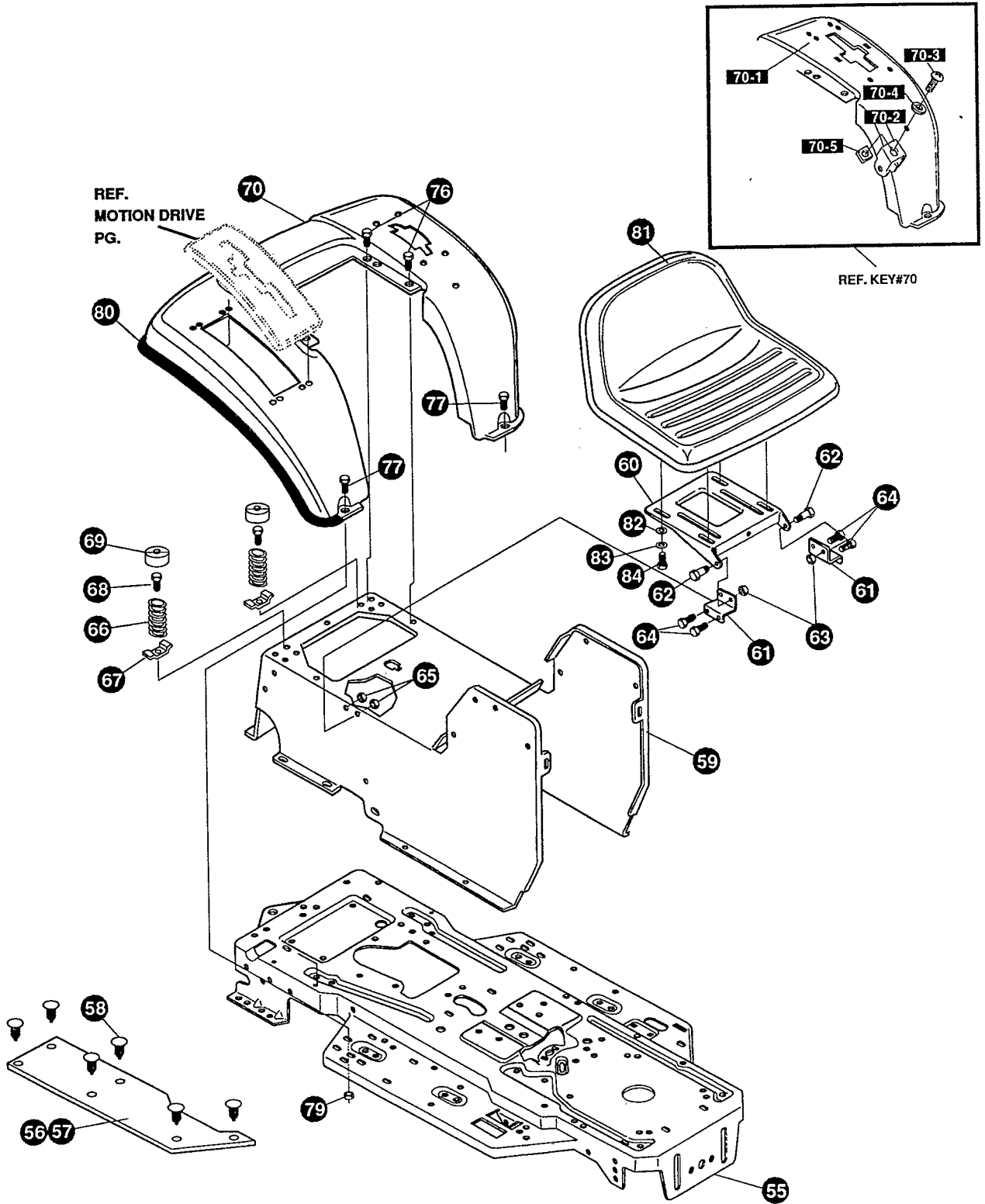

NOTE: ALWAYS USE ORIGINAL EQUIPMENT PARTS.
Use of service/replacement parts other than original equipment parts may void your warranty.

**ALL UNNUMBERED
ITEMS ARE INTERCHANGEABLE
WITH OPPOSITE SIDE**

325855 D

KEY#	PART#	DESCRIPTION	QTY
55	335697-889	FRAME, LF, MAIN, P920/F4360	1
56	310005	FOOT PAD, LH, 22.12 LONG, F-5	1
57	310006	FOOT PAD, RH, 22.12 LONG, F-5	1
58	309235	FASTENER, RATCHET, BLACK	12
59	308665-889	CONSOLE, H14-15, SOF	1
60	58367-889	PLATE, SEAT, F5, SF, LF	1
61	310660-889	BRACKET, F-5, SEAT SUPPORT	2
62	20507	BOLT, .437 X .156 HSSH, 5/16-18	2
63	1498	NUT, 5/16-18 REGHEXCTRLK	2
64	48901	SCREW, 5/16-18 X .63 WAHHC	4
65	1498	NUT, 5/16-18 REGHEXCTRLK	4
66	57153	SPRING, SEAT 2.63 LONG, 1.49 OD, BLACK	2
67	1341	CLAMP, SPRING 1.17" I D	2
68	44811	SCREW, 1/4-20 X .75 WAHHTAP	2
69	56907	COVER, SEAT SPRING 1.5 ID X 1.0 LONG	2
70	327471-889	ASSEMBLY, FENDER, F5, LF, SOF, SUSP	1
70-1	*	FENDER, F5, SUS, LF, SOF	1
70-2	9239	CLEVIS	1
70-3	439455	SCREW, 5/16-18 X .56 PHPNMA	1
70-4	301551	WASHER, .344 ID X 1.50 D X .09	1
70-5	120373	NUT, 5/16-18 SQUARE	1
76	995346	SCREW, 1/4-20 X .50 WAHHTAP	4
77	126358	BOLT, 5/16-18 X 1.00 CARRLN	2
79	55273	NUT, 5/16-18 WDFLLKLRG WHIZ	2
80	49770	TRIM, STRIP, BLACK—SMALL, W/ ADH	77.5"
81	304316	SEAT, MICHIGAN GEN, W/SWITCH HOLE	1
82	120393	WASHER, FLAT .344 X .69 X .065	4
83	120638	WASHER, HVSPTLK .328 X .60 X .09	4
84	180077	SCREW, 5/16-18 X .75 HHC	4

* REFERENCE ONLY - ASSEMBLY NOT AVAILABLE

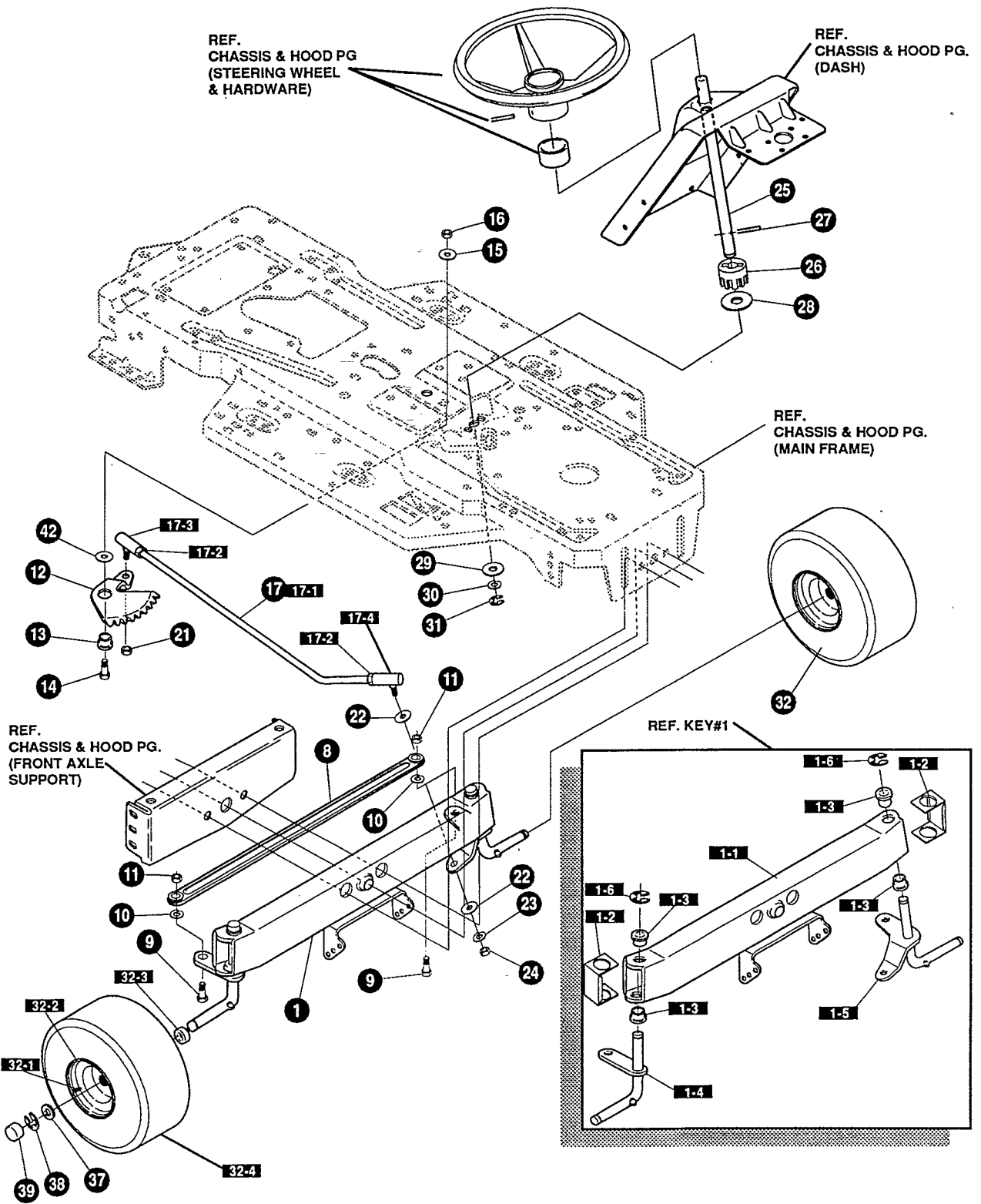

NOTE: ALWAYS USE ORIGINAL EQUIPMENT PARTS.
 Use of service/replacement parts other than original equipment parts may void your warranty.

ALL UNNUMBERED ITEMS ARE INTERCHANGEABLE WITH OPPOSITE SIDE

315136 K

KEY#	PART#	DESCRIPTION	QTY
1	*	ASSEMBLY, AXLE FRONT	1
1-1	310170	ASSEMBLY, FRONT AXLE, SUSPENDED	1
1-2	53373-853	AXLE COVER	2
1-3	52407	SPINDLE BEARING	4
1-4	302926	ASSEMBLY, SPINDLE, RH	1
1-5	315886	ASSEMBLY, SPINDLE, LH	1
1-6	36625	RING, RETEX .57 X .05 TRU 5133-75	2
8	304590	TIE ROD ASSEMBLY, 19.81 LONG W-SECTION	1
9	180128	SCREW, 3/8-16 X 1.75 HHC	2
10	120382	WASHER, REGSPTLK .393 X .68 X .10	2
11	1499	NUT, 3/8-16 REGHXCTRLK	2
12	58289	SECTOR, STEERING LF	1
13	52406	BEARING, FLANGE ECC .510 ID X .998 OD X .56	1
14	180177	SCREW, 1/2-13 X 1.50 HHC	1
15	22265	WASHER, FLAT .515 X 1.38 X .119	1
16	1500	NUT, 1/2-13 REGHCTRLK	1
17	311100	KIT 300146 DRAGLINK	1
17-1	58291	STEERING LINK	1
17-2	124925	NUT, 3/8-24 REGHEXJAM	2
17-3	57158	BALL JOINT, 3/8 THD SHORT STUD	1
17-4	21275	BALL JOINT, 3/8 THD LONG STUD	1
21	412349	NUT, 3/8-24 HEX CTRLK	1
22	996416	WASHER, FLAT .391 X 1.00 X .125	2
23	120382	WASHER, REGSPTLK .393 X .68 X .10	1
24	120369	NUT, 3/8-24 REGHEX	1
25	58243	SHAFT, STEERING	1
26	58244	PINION, STEERING	1
27	58274	PIN, DOWEL .2500 OD+1.75 LONG	1
28	301410	BEARING, FLANGE .752 ID X 1.061 OD X .24	1
29	301398	WASHER, FORMED 1.135 X 1.53 X .12	1
30	21682	WASHER, FLAT .765 X 1.25 X .042	1
31	36625	RING, RETEX .57 X .05 TRU 5133-75	1
32	302828	TIRE & RIM ASSEMBLY, PU 15 X 6.0 X 6	2
32-1	24167	VALVE STEM	
32-2	39829	RIM, WHEEL	
32-3	314416	BEARING, FLANGE	
32-4	316702	TIRE, 15 X 6 X 6	
37	642	WASHER, FLAT .755 X 1.31 X .075	4
38	36625	RING, RETEX .57 X .05 TRU 5133-75	2
39	40394	HUB CAP, 1.500 ID X 7/8 LONG	2
42	49998	WASHER, FLAT .520 X 1.25 X .209	1

* ORDER INDIVIDUAL PARTS - ASSEMBLY NOT AVAILABLE

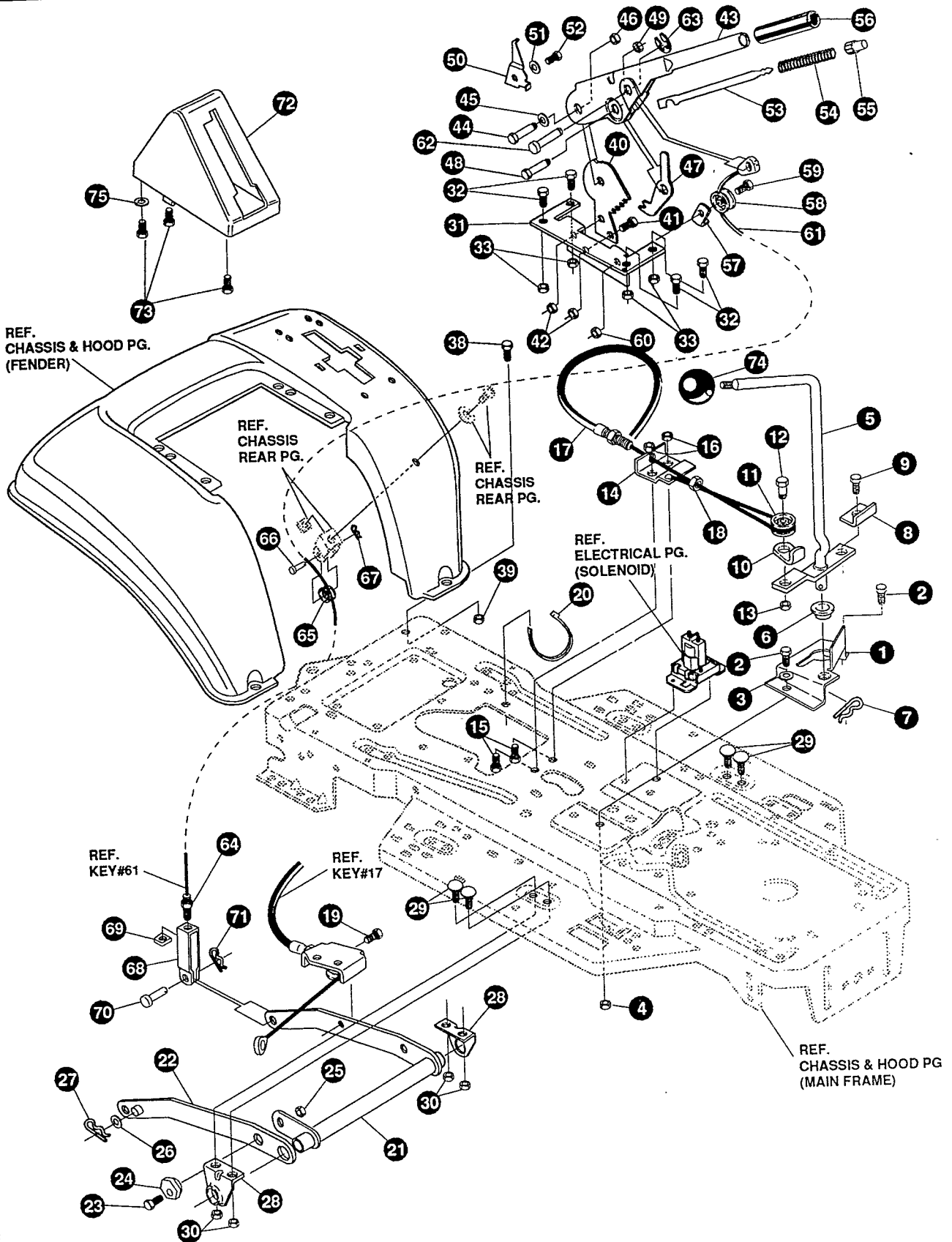

NOTE: ALWAYS USE ORIGINAL EQUIPMENT PARTS.
 Use of service/replacement parts other than original equipment parts may void your warranty.

ALL UNNUMBERED ITEMS ARE INTERCHANGEABLE WITH OPPOSITE SIDE

325815 F

KEY#	PART#	DESCRIPTION	QTY
1	320075-853	BRACKET, CLUTCH ENGAGE LEVER	1
2	180079	SCREW, 5/16-18 X 1.00 HHC	2
3	120393	WASHER, FLAT .344 X .69 X .065	2
4	1498	NUT, 5/16-18 REGHEXCTRLK	2
5	304791	ASSEMBLY, CLUTCH LEVER	1
6	50148	BEARING, FLANGE .503 ID X .63 OD X .50	1
7	8260	PIN, HAIR .091 DIA X 1.66 LONG	1
8	318341	BRACKET, SWITCH ENGAGE	1
9	35498	SCREW, 5/16-18 X .75 WAHTAP	1
10	1288	BRACKET, CABLE RETAINER	1
11	48306	PULLEY, METAL	1
12	58336	BOLT, .375 X .375 HSH, 1/4-20	1
13	1502	NUT, 1/4-20 REGHEXCTRLK	1
14	300698-853	BRACKET, FRAME CABLE	1
15	180020	SCREW, 1/4-20 X .75 HHC	2
16	1502	NUT, 1/4-20 REGHEXCTRLK	2
17	301503	ASSEMBLY, CABLE, BLADE ENGAGE	1
18	120613	NUT, 1/4-28 HJAM	1
19	35498	SCREW, 5/16-18 X .75 WAHTAP	1
20	57444	TIE, CABLE BLACK NYLON, 5.62 LONG	1
21	300158-853	LIFT ASSEMBLY, LH	1
22	300169-853	LIFT ASSEMBLY, RH	1
23	180079	SCREW, 5/16-18 X 1.00 HHC	1
24	58247	NUT, ADJUST	1
25	1498	NUT, 5/16-18 REGHEXCTRLK	1
26	417098	WASHER, FLAT .531 X 1.06 X .063	2
27	8260	PIN, HAIR .091 DIA X 1.66 LONG	2
28	58248-853	BRACKET, REAR HANG SUSPENSION	2
29	57072	BOLT, 5/16-18 X .63 CARRLN	4
30	1498	NUT, 5/16-18 REGHEXCTRLK	4
31	313926	BRACKET, HEIGHT/ADJUST SUPPORT	1
32	180077	SCREW, 5/16-18 X .75 HHC	4
33	1498	NUT, 5/16-18 REGHEXCTRLK	4
38	180077	SCREW, 5/16-18 X .75 HHC	1
39	1498	NUT, 5/16-18 REGHEXCTRLK	1
40	301238	QUADRANT, HEIGHT ADJUST	1
41	180077	SCREW, 5/16-18 X .75 HHC	2
42	1498	NUT, 5/16-18 REGHEXCTRLK	2
43	322292-853	HANDLE,LIFT SHORT(30" S.F.)	1
44	300171	BOLT, .500 X .270 HSH, 5/16-18	1
45	996418	WASHER, FLAT .506 X .75 X .024	1
46	44108	NUT, 5/16-18 HWDFLCTRLK	1
47	301239	PAWL, SQUARE	1
48	300171	BOLT, .500 X .270 HSH, 5/16-18	1
49	44108	NUT, 5/16-18 HWDFLCTRLK	1
50	9435	POINTER, HEIGHT ADJUST	1
51	138479	WASHER, EXLK .195 X .41 X .03	1
52	35287	SCREW, #8-32 X .38 HHWATAP	1
53	303027	ROD, ACTUATOR-SHORT	1
54	58326	SPRING, HEIGHT ADJUST	1
55	58325	KNOB, HEIGHT ADJUST, PUSH BUTTON	1
56	58329	GRIP, .750 OD, W/ HOLE BLACK	1
57	9149	BRACKET, CABLE RETAINER	1
58	48306	PULLEY, METAL	1
59	58336	BOLT, .375X .375 HSH, 1/4-20	1
60	1502	NUT, 1/4-20 REGHEXCTRLK	1
61	314177	CABLE, LIFT, 22.92, F-5, 20 X 8-8	1
62	300310	PIN, CLEVIS .310 DIA+.475 LONG	1
63	300311	RING, RET E .31 X .25 TRU 5133-31	1
64	120375	NUT, 1/4-20 REGHEX	1
65	48306	PULLEY, METAL	1
66	300317	PIN, CLEVIS .375 DIA X .81 LONG	1
67	8260	PIN, HAIR .091 DIA X 1.66 LONG	1
68	9405	CLEVIS, LIFT CABLE	1
69	120372	NUT, 1/4-20 REGSQ	1
70	39522	PIN, CLEVIS .312 X .812	1
71	121222	PIN, COTTER .090 DIA X .75 LONG	1
72	333903	LIFT COVER, F5, LF, SF, BLACK	1
73	300340	SCREW, #10 X .75 HHPLAST, BLACK	3
74	55514	KNOB, ROUND 1.50 DIA, BLACK	1
75	120392	WASHER, FLAT .281 X .63 X .065	1

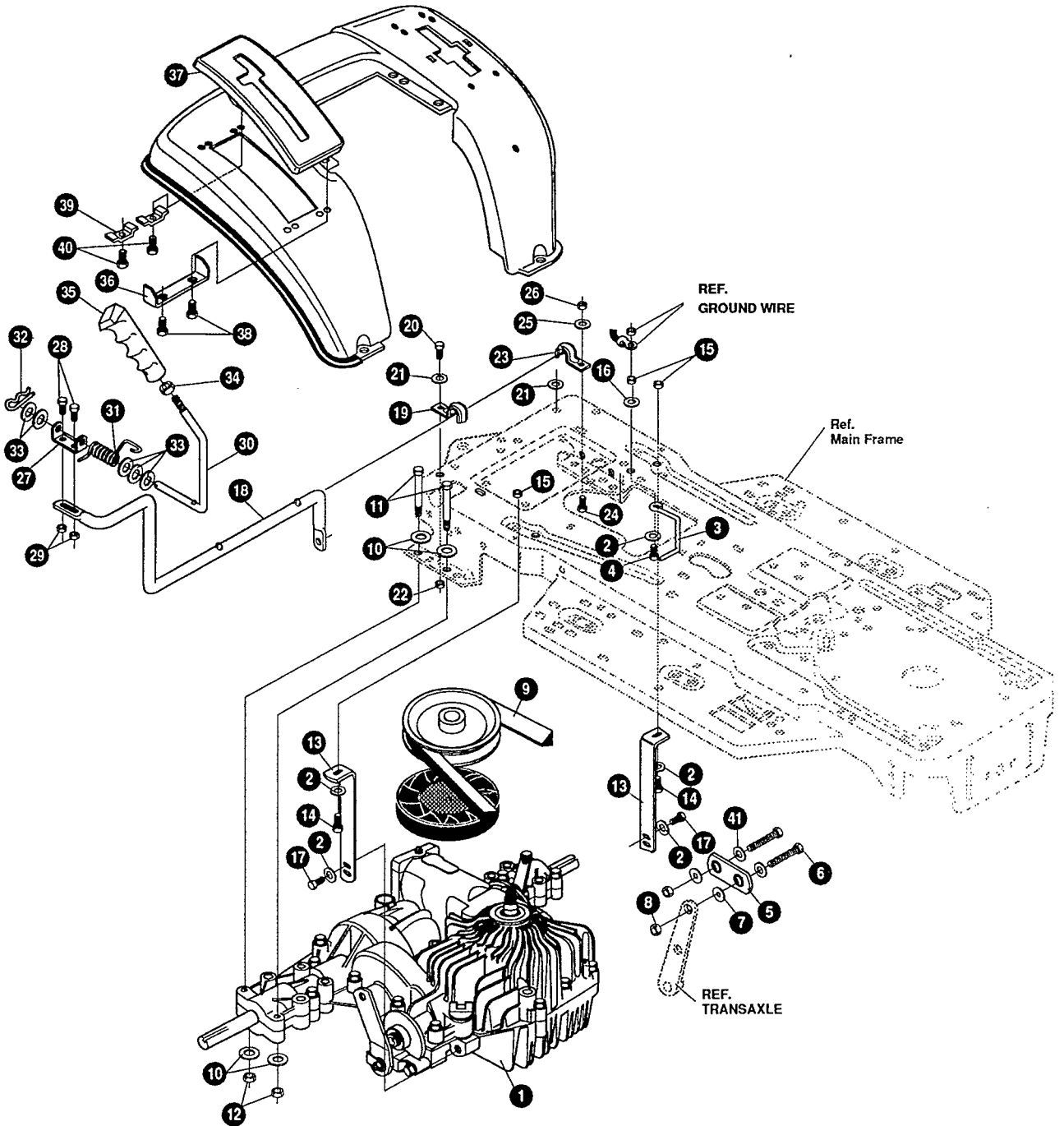

NOTE: ALWAYS USE ORIGINAL EQUIPMENT PARTS.
Use of service/replacement parts other than original equipment parts may void your warranty.

**ALL UNNUMBERED
ITEMS ARE INTERCHANGEABLE
WITH OPPOSITE SIDE**

335520 A

KEY#	PART#	DESCRIPTION	QTY
1	*	TRANSAXLE, PEERLESS, VST, 205, 2WS	1
2	120393	WASHER, FLAT .344 X .69 X .065	6
3	326633	BELT GUIDE	1
4	180079	SCREW, 5/16-18 X 1.00 HHC	1
5	326678	LINK, TIE ROD, SHIFT, PEERLESS	1
6	180124	SCREW, 3/8-16 X 1.25 HHC	2
7	120394	WASHER, FLAT .406 X .81 X .065	2
8	1499	NUT, 3/8-16 REGHXCTRLK	2
9	332547	BELT, V 4L, 78.75, HYDRO, LF	1
10	120393	WASHER, FLAT .344 X .69 X .065	8
11	180091	SCREW, 5/16-18 X 2.50 HHC	4
12	1498	NUT, 5/16-18 REGHEXCTRLK	4
13	326684	BRACKET, STABILIZER	2
14	180077	SCREW, 5/16-18 X .75 HHC	1
15	1498	NUT, 5/16-18 REGHEXCTRLK	3
16	138538	WASHER, REGINTLK .320 X .61 X .03	1
17	35498	SCREW, 5/16-18 X .75 WAHTAP	1
18	325392	LEVER, SHIFT-LOWER, LF, BLACK	1
19	310347-853	CLIP- SHIFT LEVER .625 ROD	1
20	180077	SCREW, 5/16-18 X .75 HHC	1
21	996416	WASHER, FLAT .391 X 1.00 X .125	1
22	1498	NUT, 5/16-18 REGHEXCTRLK	1
23	310347-853	CLIP- SHIFT LEVER .625 ROD	1
24	180077	SCREW, 5/16-18 X .75 HHC	1
25	996416	WASHER, FLAT .391 X 1.00 X .12	1
26	1498	NUT, 5/16-18 REGHEXCTRLK	1
27	310356	BRACKET, PIVOT SHIFT LEVER	1
28	180020	SCREW, 1/4-20 X .75 HHC	2
29	1502	NUT, 1/4-20 REGHEXCTRLK	2
30	318452	LEVER, SHIFT, UPPER, SOF, 1/2-13	1
31	318451	SPRING, TORSION, .56 X .95 X .095	1
32	8260	PIN, HAIR .091 DIA X 1.66 LONG	1
33	2968	WASHER, FLAT .504 X .75 X .059	5
34	120238	NUT, 1/2-13 HEXJAM	1
35	306690	HANDLE, 1/2-13 MOLDED, BLACK	1
36	311257-853	BRACKET, COVER, F-5 FENDER, SHIFT	1
37	314244	COVER, PLASTIC, LF, HYDRO, F-5	1
38	311331	SCREW, 1/4-15 X .44/.53 HILOHWA	2
39	1341	CLAMP, SPRING 1.17"ID	2
40	311331	SCREW, 1/4-15 X .44/.53 HILOHWA	2

* CONTACT YOUR NEAREST TRANSAXLE DEALER FOR PARTS & SERVICE

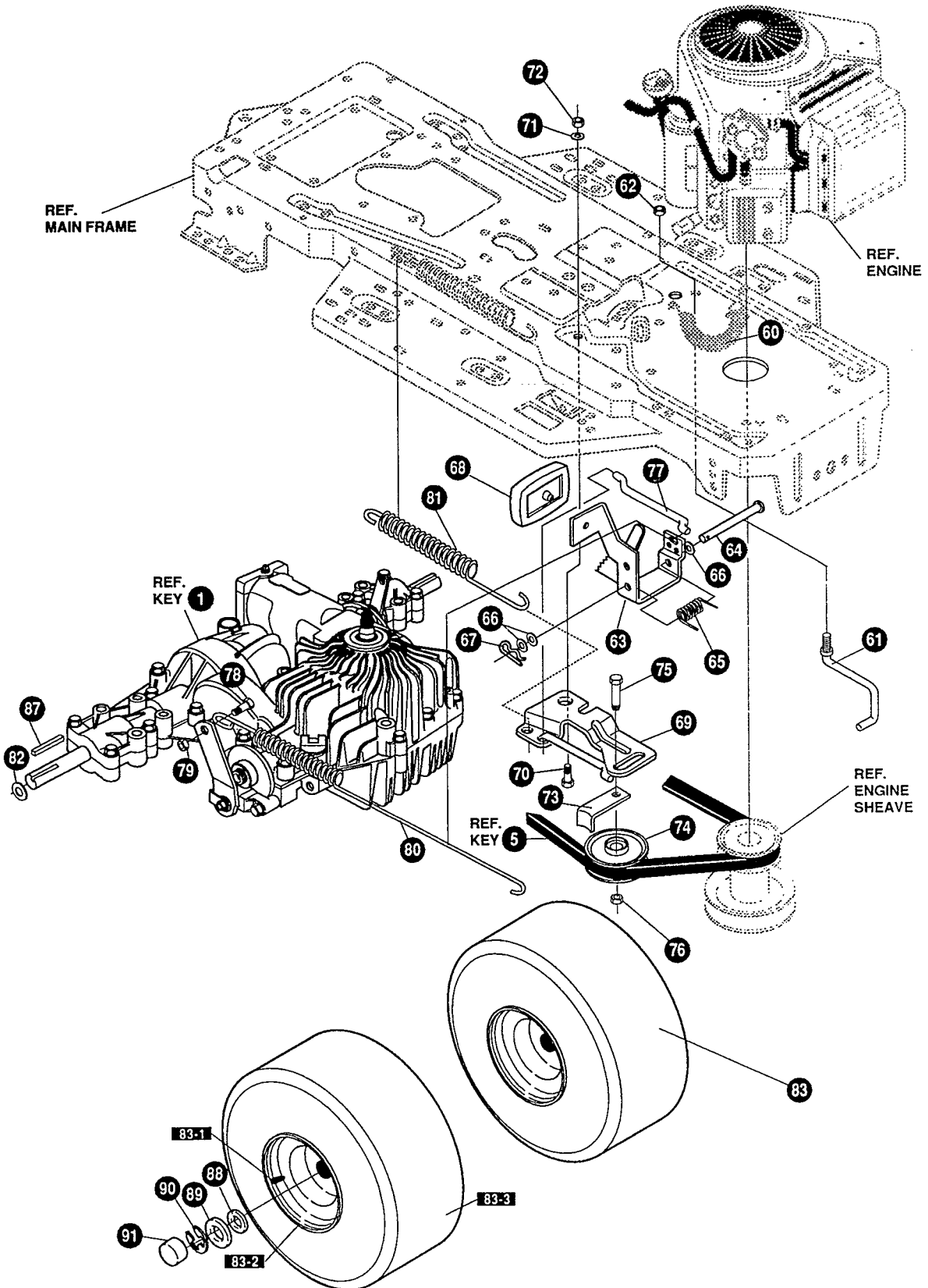

NOTE: ALWAYS USE ORIGINAL EQUIPMENT PARTS.
Use of service/replacement parts other than original equipment parts may void your warranty.

**ALL UNNUMBERED
ITEMS ARE INTERCHANGEABLE
WITH OPPOSITE SIDE**

335520 A

KEY#	PART#	DESCRIPTION	QTY
60	321514	SPRING, DRAG LINK BIAS	1
61	304016	GUIDE, BELT, RH	1
62	1498	NUT, 5/16-18 REGHEXCTRLK	1
63	325942	PEDAL ASSEMBLY, BRAKE/CLUTCH, LF	1
64	319675	PIN, CLEVIS .500 D X 4.53 LONG	1
65	57847	SPRING, BRAKE PEDAL	1
66	2968	WASHER, FLAT .504 X .75 X .059	3
67	56180	PIN, HAIR .091 DIA X 1.62 LONG	1
68	48160	PAD, CLUTCH BRAKE W/PRINTING	1
69	320381-853	ARM, IDLER TRACTION, SOG, LF	1
70	329989	BOLT, .625 X .135 HSH, 5/16-18	1
71	45602	WASHER, FLAT .333 X .87 X .119	1
72	1498	NUT, 5/16-18 REGHEXCTRLK	1
73	39659	RETAINER, BELT	1
74	35374	PULLEY, IDLER, V4L, 3.06 X .62	1
75	45892	BOLT, 3/8-16 X 1.50 CARRSN	1
76	1499	NUT, 3/8-16 REGHXCTRLK	1
77	57204	ROD, CLUTCH 3.92"	1
78	326131	BOLT, .495 X .31 HSH, 5/16-18	1
79	1498	NUT, 5/16-18 REGHEXCTRLK	1
80	327947	SPRING, BRAKE 29.25, LF, PEERLESS, HYDRO	1
81	330505	SPRING, CLUTCH .113 X .750 X 8.75	1
82	42815	WASHER, FLAT .755 X 1.53 X .07	4
83	301318	TIRE & RIM ASSEMBLY, 20 X 10.00-8	2
83-1	24167	VALVE STEM	
83-2	301366	RIM, WHEEL	
83-3	319686	TIRE, 20 X 10 X 8	
87	52928	KEY, SQUARE .187 SQUARE X 2.25 LONG	2
88	642	WASHER, FLAT .755 X 1.31 X .075	4
89	42815	WASHER, FLAT .755 X 1.53 X .07	2
90	36625	RING, RETEX .57 X .05 TRU 5133-75	2
91	40394	HUB CAP, 1.500 ID X 7/8 LONG	2

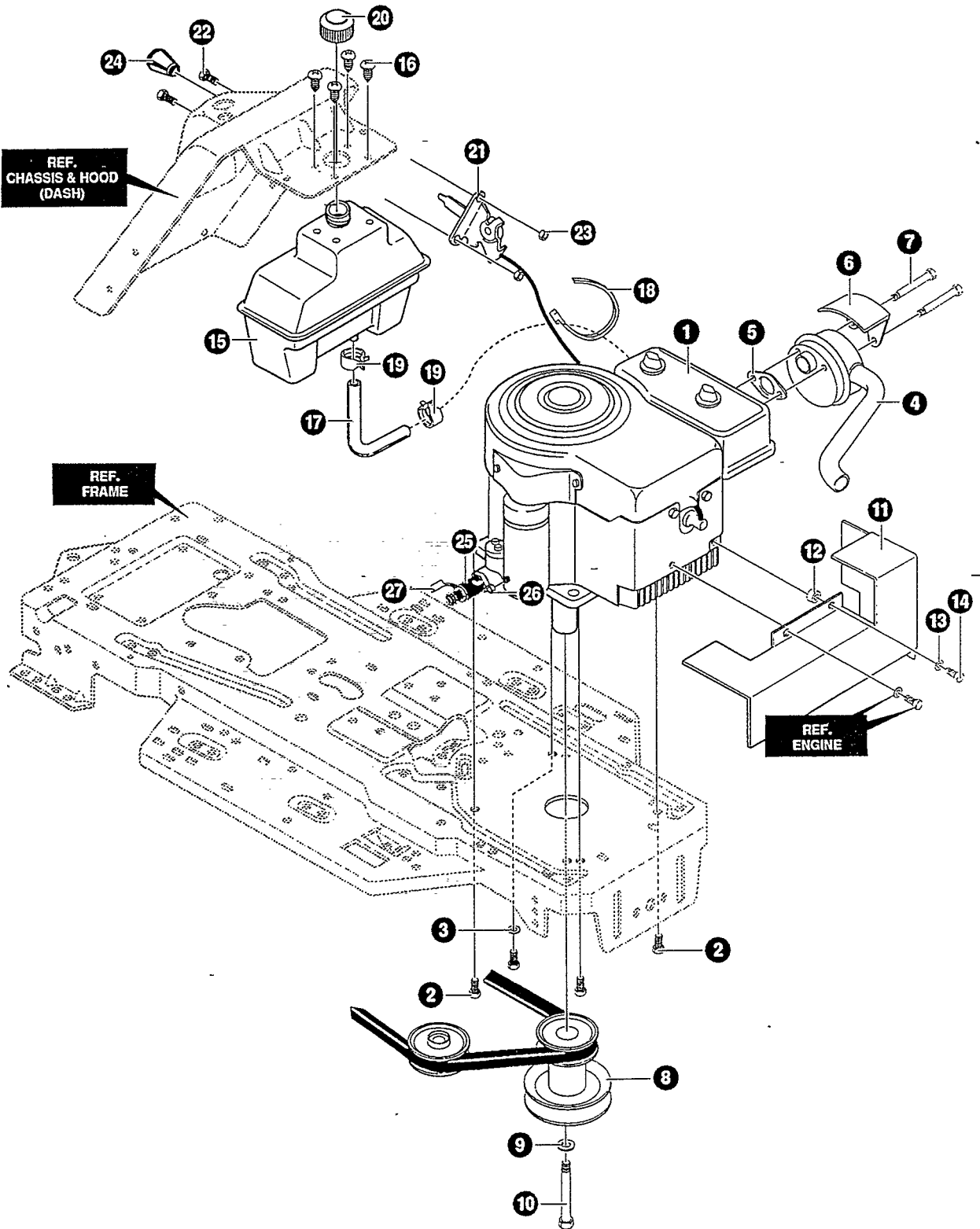

NOTE: ALWAYS USE ORIGINAL EQUIPMENT PARTS.
Use of service/replacement parts other than original equipment parts may void your warranty.

**ALL UNNUMBERED
ITEMS ARE INTERCHANGEABLE
WITH OPPOSITE SIDE**

337049 A

F3560-071

ENGINE & CONTROL ASSEMBLY

KEY#	PART#	DESCRIPTION	QTY
1	*	ENGINE, 12-12.5HP, B&S, IC DUAL	1
2	50947	SCREW, 3/8-1 6X 1.25 WAHTAP	4
3	138489	WASHER, EXLK .384 X .69 X .04	1
4	305367	MUFFLER, LO TONE NELSON EXPORT	1
5	46708	GASKET, MUFFLER	1
6	54767	SHIELD, HEAT, FOR ROUND MUFFLER	1
7	54980	SCREW, 5/16-18 X 3.50 HHC	2
8	326567	PULLEY, ENGINE 4.0D X 4.0LONG X 5.0D	1
9	120383	WASHER, REGSPTLK .459 X .78 X .12	1
10	433146	SCREW, 7/16-20 X 4.25 HHC, BLACK	1
11	308543-853	HEAT SHIELD ASSEMBLY, 11 & 12HP	1
12	41462	SPACER, SLEEVE .328 X .75X .312 PM	1
13	120380	WASHER, REGSPTLK .263 X .49 X .07	1
14	180022	SCREW, 1/4-20 X 1.00 HHC	1
15	314989	TANK, FUEL 1 GALLON, CLEAR	1
16	49050	SCREW, 1/4-10 X .75 PHPNTAP	4
17	50118	TUBING, .25 X .50 X BULK GAS LINE	13.5"
18	57444	TIE, CABLE BLACK NYLON 5.62L	1
19	336890	CLAMP, FUEL LINE YELLOW	1
20	46704	CAP, GAS 1-1/2-7 THD, BLACK	1
21	321273	CONTROL, THROTTLE 12-12.5HP, LF	1
22	320553	SCREW, 10-24 X .63 PHPNMA	2
23	308459	NUT, #10-24 HXHDNYLK	2
24	50607	KNOB, ROUND THROTTLE, BLACK	1
25	325547	OIL DRAIN VALVE ASSEMBLY	1
26	124818	NUT, 1/4-20 REGHXJAM	1
27	327422	CAP, OIL DRAIN VALVE ASSEMBLY, YELLOW	1

* SEE ENGINE MANUAL

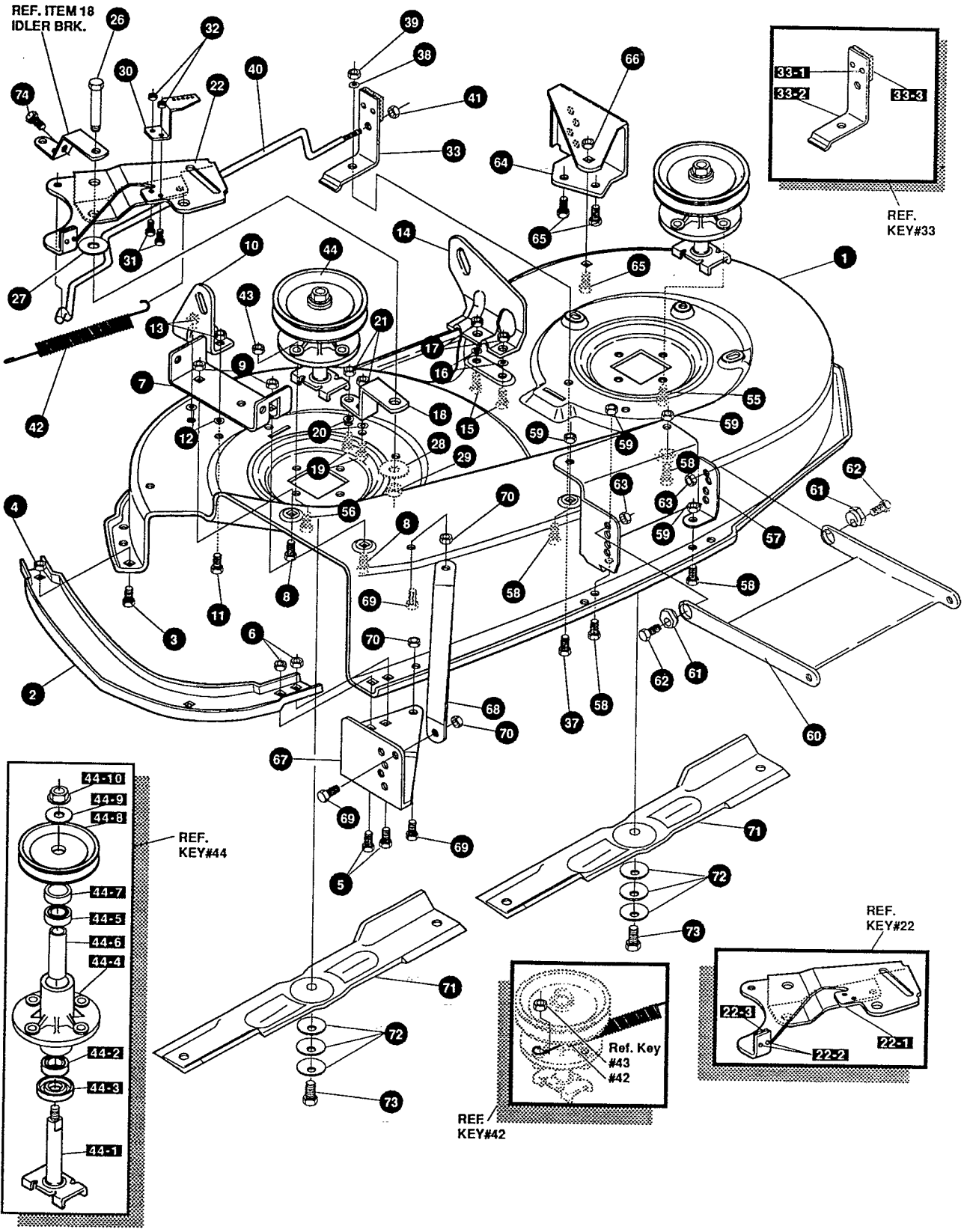

NOTE: ALWAYS USE ORIGINAL EQUIPMENT PARTS.
Use of service/replacement parts other than original equipment parts may void your warranty.

**ALL UNNUMBERED
ITEMS ARE INTERCHANGEABLE
WITH OPPOSITE SIDE**

320109 H

KEY#	PART#	DESCRIPTION	QTY
1	325103	40" DECK KIT	1
2	326480-853	TOE GUARD - MULCHER	1
3	180077	SCREW, 5/16-18 X .75 HHC	1
4	1498	NUT, 5/16-18 REGHEXCTRLK	1
5	180077	SCREW, 5/16-18 X .75 HHC	2
6	1498	NUT, 5/16-18 REGHEXCTRLK	2
7	317017	BRACKET CHUTE MOUNT	1
8	180077	SCREW, 5/16-18 X .75 HHC	2
9	1498	NUT, 5/16-18 REGHEXCTRLK	2
10	313929	BRACKET, RH, LIFT REAR	1
11	180077	SCREW, 5/16-18 X .75 HHC	2
12	120393	WASHER, FLAT .344 X .69 X .065	2
13	1498	NUT, 5/16-18 REGHEXCTRLK	2
14	310667	BRACKET, LH, LIFT REAR	1
15	180077	SCREW, 5/16-18 X .75 HHC	2
16	120393	WASHER, FLAT .344 X .69 X .065	2
17	1498	NUT, 5/16-18 REGHEXCTRLK	2
18	326893-853	BRACE, IDLER SUPPORT, 40", 43"	1
19	180077	SCREW, 5/16-18 X .75 HHC	2
20	120393	WASHER, FLAT .344 X .69 X .065	2
21	44108	NUT, 5/16-18 HWDFLCTRLK	2
22	320576-853	IDLER ARM ASSEMBLY	1
22-1	322116-853	ARM, IDLER, 40/43" DECK	1
22-2	41601	RIVET, OVSET .187 DIA X .50 LONG	2
22-3	306973	BRAKE PAD - HARD-NF343 (X-31)	1
26	304420	BOLT, .500 X 2.15 HSH	1
27	996307	WASHER, FLAT .391 X 1.00 X .209	1
28	996416	WASHER, FLAT .391 X 1.00 X .125	2
29	45171	NUT, 3/8-16 HWDFL WHIZ-LOCK	1
30	326249-853	BRACKET, EXTENSION IDLER	1
31	180077	SCREW, 5/16-18 X .75 HHC	2
32	1498	NUT, 5/16-18 REGHEXCTRLK	2
33	321828	BLADE BRAKE ASSEMBLY	1
33-1	135624	RIVET, TRSET .185 DIA X .41 LONG	2
33-2	304119-853	BRAKE ARM	1
33-3	306973	BRAKE PAD - HARD-NF343 (X-31)	1
37	180077	SCREW, 5/16-18 X .75 HHC	1
38	120393	WASHER, FLAT .344 X .69 X .065	1
39	1498	NUT, 5/16-18 REGHEXCTRLK	1
40	302714	ROD, BRAKE	1
41	1502	NUT, 1/4-20 REGHEXCTRLK	1
42	35410	SPRING, .071 X .62 X 4.37	1
43	1498	NUT, 5/16-18 REGHEXCTRLK	1
44	56424-853	QUILL ASSEMBLY, 36/39/40/43	2
44-1	56425	SHAFT/SADDLE 36"	1
44-2	49562	BEARING, BALL 6203-2AA-C3 ARMORED	1
44-3	50616	DUST SHIELD	1
44-4	55547	QUILL CASTING (1046)	1
44-5	49562	BEARING, BALL 6203-2AA-C3 ARMORED	1
44-6	50818	SPACER, SLEEVE .669 X .88 X 3.797	1
44-7	51449	SPACER, SLEEVE .672 X .93 X .438	1
44-8	313898	PULLEY, 26/36" QUILL V5L	1
44-9	56365	WASHER, SPECIAL QUILL	1
44-10	1282	NUT, 7/16-20 WDFLLK	1
55	35498	SCREW, 5/16-18 X .75 WAHHTAP	7
56	300345	SCREW, 5/16-18 X 1.38 WAHHTAP	1
57	318445-853	BRACKET, 40", LF, FRONT DECK	1
58	180077	SCREW, 5/16-18 X .75 HHC	4
59	1498	NUT, 5/16-18 REGHEXCTRLK	4
60	58305-853	BRACKET, LINK DECK FRONT	1
61	58247	NUT, ADJUST	2
62	180079	SCREW, 5/16-18 X 1.00 HHC	2
63	1498	NUT, 5/16-18 REGHEXCTRLK	2
64	317041	BRACKET, GAGE WHEEL, LH	1
65	180077	SCREW, 5/16-18 X .75 HHC	3
66	1498	NUT, 5/16-18 REGHEXCTRLK	3
67	322464-853	BRACKET, GAGE WHEEL, RH, FRONT	1
68	314282-853	BRACKET, STABILIZER	1
69	180077	SCREW, 5/16-18 X .75 HHC	3
70	1498	NUT, 5/16-18 REGHEXCTRLK	3
71	313316	BLADE, 40", STD-LIFT, 20.32	2
72	2483	WASHER, .39 ID X 1.25 D X .07 BELLVIL	6
73	39573	SCREW, 3/8-24 X 1.00 NYLHHC	2
74	308231	SCREW, 1/4-20 X 1.25 HHWATAP	1

REF.
IDLER ARM

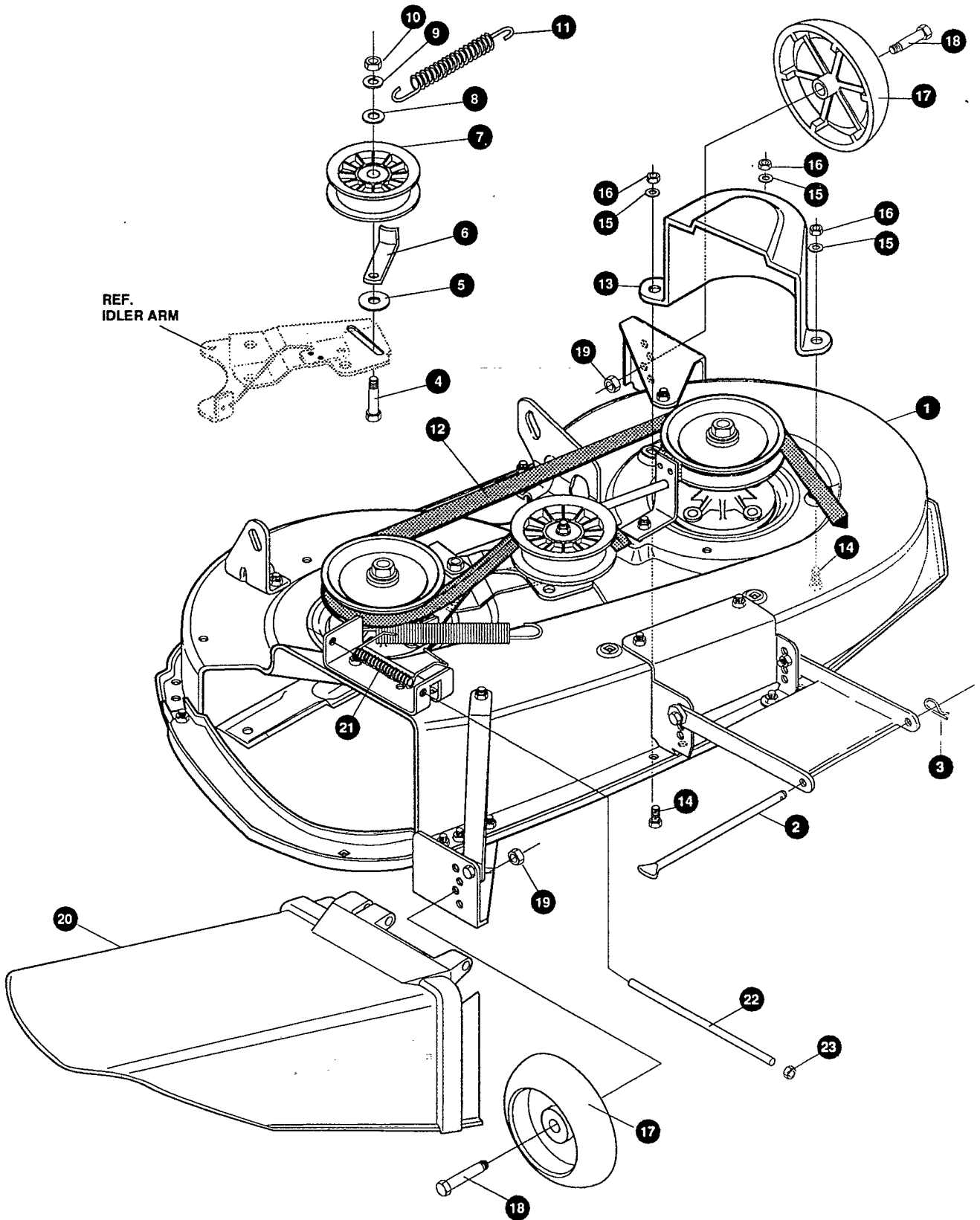

NOTE: ALWAYS USE ORIGINAL EQUIPMENT PARTS.
Use of service/replacement parts other than original equipment parts may void your warranty.

**ALL UNNUMBERED
ITEMS ARE INTERCHANGEABLE
WITH OPPOSITE SIDE**

325682 B

KEY#	PART#	DESCRIPTION	QTY
1	329035	ASSEMBLY, 40" SUS DECK, EXPORT	1
2	58306	ROD, DECK HITCH	1
3	8260	PIN, HAIR .091 DIA X 1.66 LONG	1
4	57325	BOLT, 3/8-16 X 2.00 CARRSN	1
5	25210	WASHER, FLAT .386 X 1.25 X .09	1
6	1346	RETAINER, BELT	1
7	310326	PULLEY, IDLER BFF, 4.00 WIDE FL	1
8	996307	WASHER, FLAT .391 X 1.00 X .209	1
9	120382	WASHER, REGSPTLK .393 X .68 X .10	1
10	120377	NUT, 3/8-16 REGHX	1
11	300473	SPRING, TENSION 7.52 LONG+17 LB/IN	1
12	319005	BELT, V 5L, 81.00 DECK, 40", LF	1
13	328257	GUARD, BELT, LH, PLASTIC	1
14	180077	SCREW, 5/16-18 X .75 HHC	3
15	120393	WASHER, FLAT .344 X .69 X .065	3
16	1498	NUT, 5/16-18 REGHEXCTRLK	3
17	302611	GAUGE WHEEL, EURO 6.00 OD X 1.38 WD	2
18	23763	BOLT, .500 X 1.390 HHSH, 3/8-16	2
19	1499	NUT, 3/8-16 REGHXCTRLK	2
20	304422	CHUTE DEFLECTOR, 40", 42" & 43"	1
21	314975	SPRING, TORSION CHUTE DEFLECTOR	1
22	304424	ROD, PIVOT DECK .312 D X 7.25	1
23	3535	NUT, PUSH ON CAP .312 OD	1

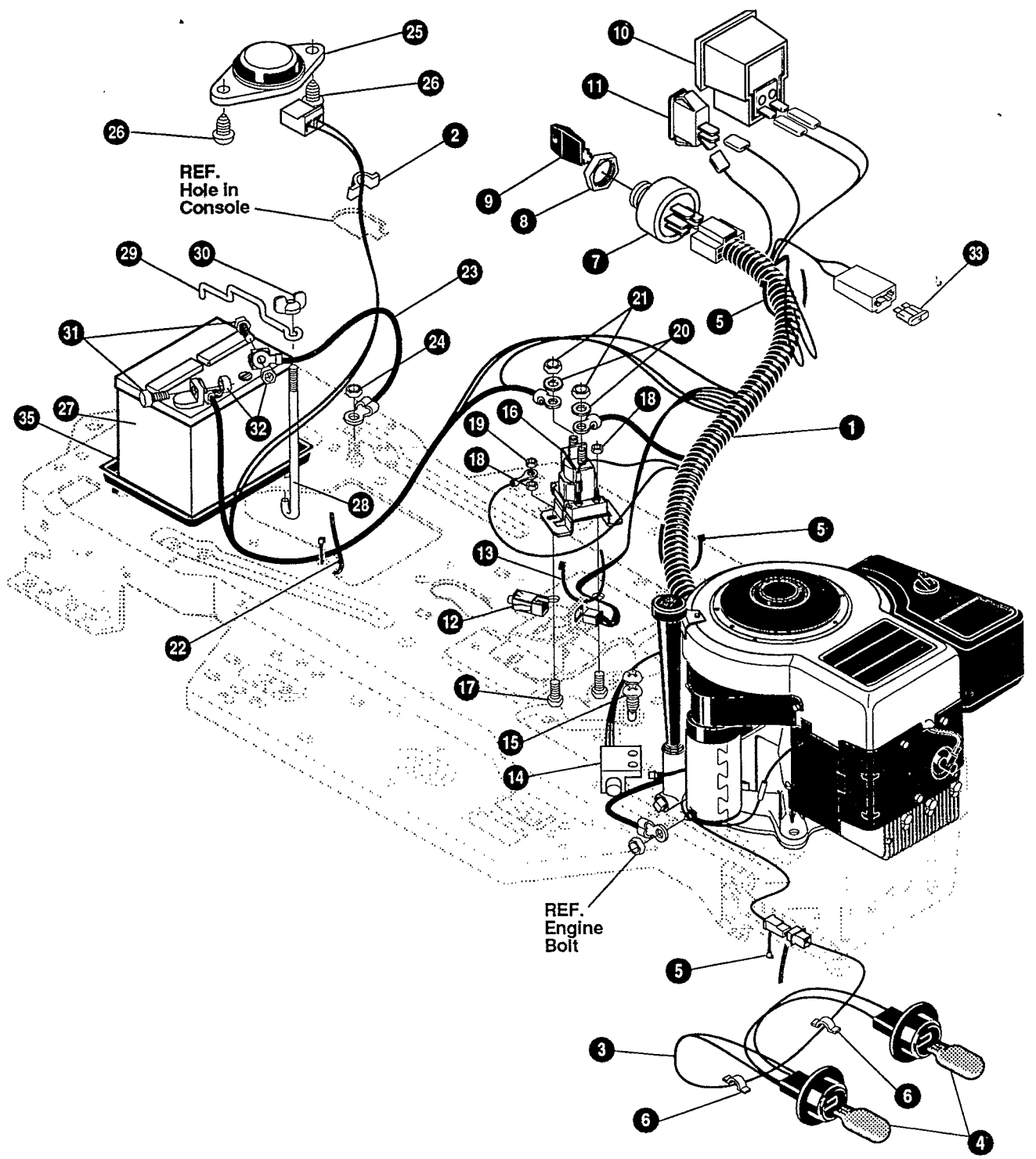

NOTE: ALWAYS USE ORIGINAL EQUIPMENT PARTS.
 Use of service/replacement parts other than original equipment parts may void your warranty.

ALL UNNUMBERED ITEMS ARE INTERCHANGEABLE WITH OPPOSITE SIDE

325502 D

KEY#	PART#	DESCRIPTION	QTY
1	320065	HARNES, WIRE, 12-12.5HP, B&S, H14, WRAP, LF ..	1
2	41482	PRESS CLIP, 1.380 LONG .255 ID	1
3	303064	ASSEMBLY, LIGHT WIRE-1/4 TURN	1
4	52572	BULB, HEADLAMP	2
5	57444	TIE, CABLE BLACK NYLON, 5.62 LONG	3
6	41482	PRESS CLIP, 1.380 LONG .255 ID	2
7	327355	SWITCH-IGNITION (AFTER FIRE) 3 POSITION	1
8	327352	NUT, 5/8-8 ACME DELTA FOR BOOT	1
9	327350	KEY, IGNITION	2
10	300133	AMMETER	1
11	300334	LIGHT SWITCH, ON/OFF, PANEL MOUNT	1
12	320082	SWITCH, DOUBLE POLE NO/NC GRAY	1
13	57444	TIE, CABLE BLACK NYLON, 5.62 LONG	1
14	57476	SWITCH, SCREW MOUNT DP, NC, NO, BLACK	1
15	57220	SCREW, #12 X .50 PHPNHTAP, BLACK	2
16	53716	SOLENOID	1
17	187745	SCREW, 1/4-20 X .75 HXSEMMA	2
18	1502	NUT, 1/4-20 REGHEXCTRLK	2
19	271172	NUT, 1/4-20 REGHEXKEPS	1
20	138485	WASHER, EXLK .320 X .61 X .03	2
21	120368	NUT, 5/16-24 REGHEX	2
22	57444	TIE, CABLE BLACK NYLON, 5.62 LONG	1
23	55511	WIRE, GROUND, 12.5"	1
24	271184	NUT, 5/16-18 HEXKEPS	1
25	57547	SWITCH, SEAT	1
26	160505	SCREW, 1/4-20 X .38 PHPNHMA	2
27	92693	BATTERY, 12V (MAINTENANCE FREE)	1
28	57551	ROD, BATTERY	1
29	57552	ROD, BATTERY, TOP	1
30	325232	NUT, WING 1/4-20 NYLON	1
31	180020	SCREW, 1/4-20 X .75 HHC	2
32	271172	NUT, 1/4-20 REGHEXKEPS	2
35	91895	TRAY - BATTERY	1

SCHEMATIC DRAWING

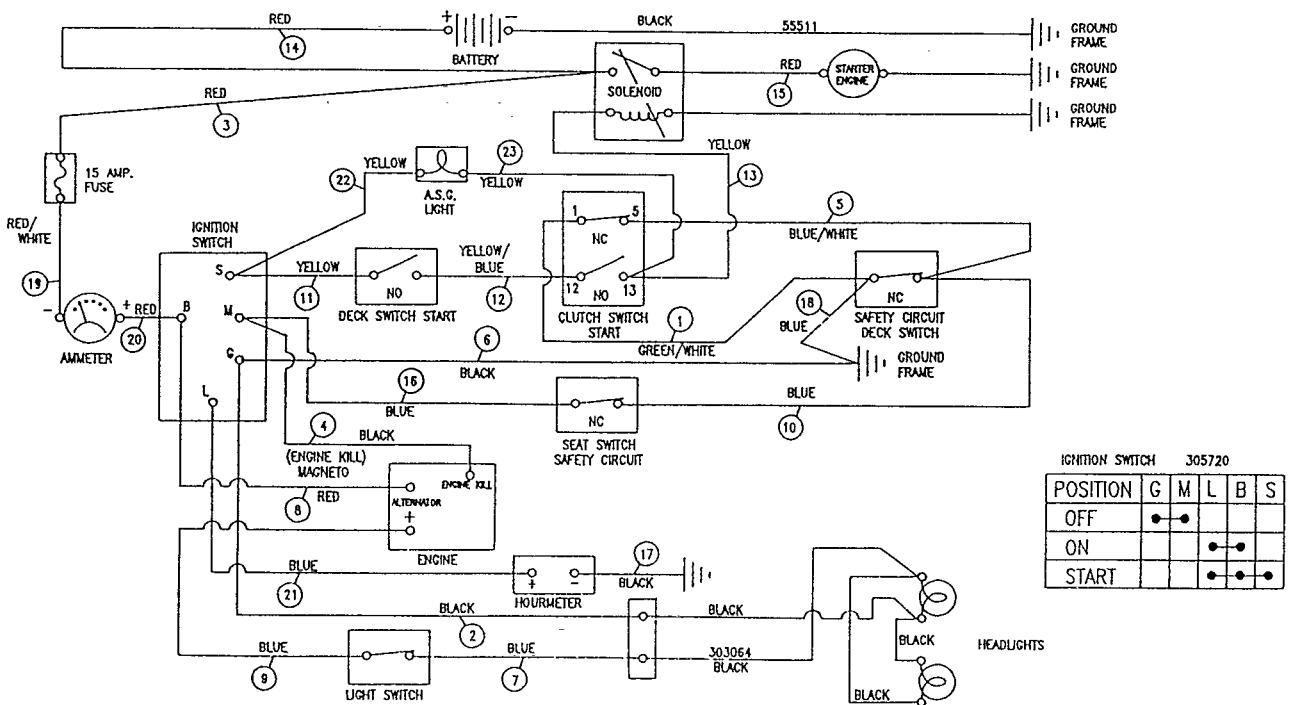

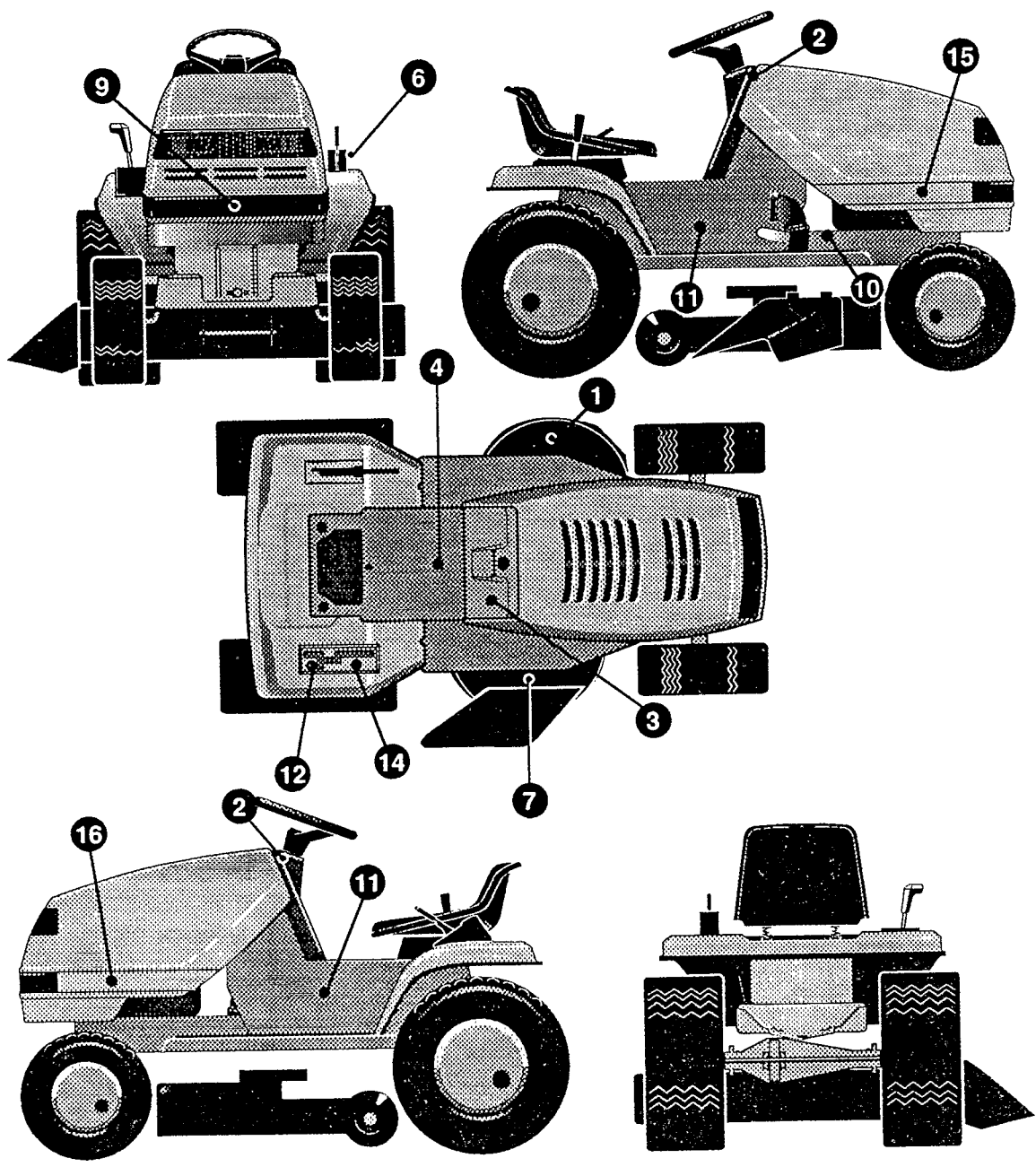

KEY#	PART#	DESCRIPTION	QTY
1	402700	DECAL, CAUTION DECK, LH	1
2	313210	DECAL, DASH, WEAR STRIP, BLACK	2
3	321765	DECAL, LF, DASH, PTO/LIGHT SWITCH, EXP	1
4	402689	DECAL, CONSOLE, SYMBOLIC, CAUTION	1
6	402214	DECAL, HEIGHT ADJUST	1
7	402701	DECAL, CAUTION DECK, RH, CUT HAND	1
9	322700	DECAL, TAPE H14, 8MIL, VINYL	1
10	402702	DECAL, BRAKE/CLUTCH	1
11	402496	NAMEPLATE, 13/40	2
12	314925	DECAL, SHIFT, LF, HYDRO, REVERSE	1
14	314923	DECAL, SHIFTER, LF, HYDRO, FORWARD	1
15	402736	DECAL, TEXAS, H-15, RH	1
16	402735	DECAL, TEXAS, H-15, LH	1

Contact the dealer where your tractor was purchased for the available accessories. If you are unable to contact the dealer, write to the address on the warranty page of your Operator's manual.

LARGE LAWN TRACTOR

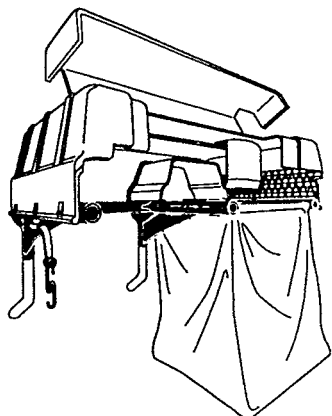

Model # 5708-34
Grass Collector for
40, 42, 43" decks

For heavy duty grass
collection order Model
#5709-10 Air Assist

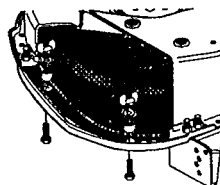

5717-00
Mulching Kit (42/43" Deck)
5716-00
Mulching Kit (40" Deck)

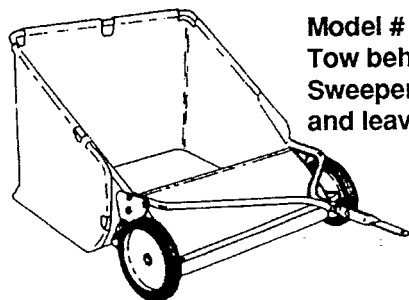
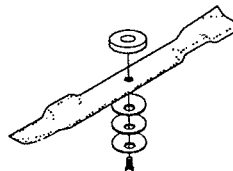

Model # 5648-16
Tow behind Lawn
Sweeper for grass
and leaves

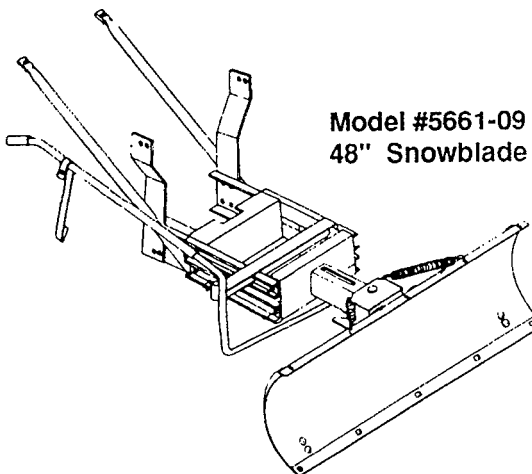

Model #5661-09
48" Snowblade

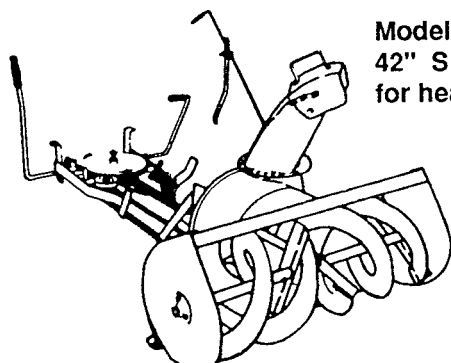

Model #5705-06
42" Snowthrower
for heavy snowfall

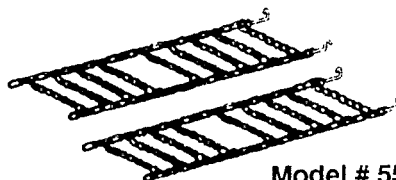

Model # 5585-00
Tire Chains - 20" x 8.0" tires
Model # 5706-00
Tire Chains - 20" x 10.0" tires

OTHER ACCESSORIES

Model	Description
5672-01	Wheel Weights - Front - 1 pr. w/mtg. hdw. - Fits 15" tires
5673-02	Wheel Weights - Rear - 1 pr. w/mtg. hdw. - Fits 18" & 20" tires
309070	40" High Lift Blade for Bagging or Side Discharge (Requires 2)
330277	40" Mulching Blade (Requires 2)
316608	43" High Lift Blade for Bagging or Side Discharge (Requires 2)
325762	43" Mulching Blade (Requires 2)