

REPAIR PARTS MANUAL

39" - 12 H.P. LAWN TRACTOR

MODEL B3560-830

1991

ONE YEAR LIMITED WARRANTY

For one (1) year from date of purchase by the first consumer for residential use (thirty (30) days commercial use), NOMA Outdoor Products Incorporated warrants that it will replace free of charge, including labor, any original part of any NOMA Outdoor Products Incorporated product found to be defective by any authorized Service Dealer or the factory, except the battery which is warranted for ninety (90) days from date of purchase.

This warranty does not cover engine, transmission, transaxle or differential (these items are covered by their manufacturer's own warranty). This warranty does not cover parts that have failed due to normal wear or parts that have failed subject to misuse or abuse. Transportation of the unit or part to and from an authorized Service Dealer or factory is the responsibility of the owner.

A step by step explanation as to what procedure should be followed for this warranty is:

1. If a part becomes defective, contact the store where the unit was purchased for the name and address of the authorized Service Dealer nearest to you.
2. If you cannot locate an authorized Service Dealer, write Service Department of NOMA Outdoor Products Incorporated for the name and address of the authorized Service Dealer in your area or call the Service Department at 1-901-422-1690.
3. Return the defective product, along with proof of purchase to such authorized Service Dealer for replacement of any defective part where covered by this warranty.

There is no other express warranty. Implied warranties, including those of merchantability and fitness for a particular purpose are limited to one (1) year from date of purchase. Liability for incidental or consequential damages are excluded.

Some states do not allow limitations on how long an implied warranty lasts, so the above limitation may not apply to you. Some states do not allow the exclusion of incidental or consequential damages, so the above exclusion may not apply to you. This warranty gives you specific legal rights, and you may have other rights which vary from state to state.

NOMA Outdoor Products Incorporated

Caller 8000

Jackson, TN 38308-8000

UNIT PARTS AND SERVICE

This manual contains instructions for safety, assembly and maintenance. Read this manual carefully and completely so that you will know proper assembly, use and care of your unit. Also fill in and mail the registration card packed with the unit. For service other than covered in this manual, contact an authorized service dealer. A nationwide parts and service organization has been established to provide locally available parts and service. A list of authorized parts distributors has been included in this manual. When ordering repair parts, always give the following information: 1. The Part Name; 2. The Part Number; 3. The Quantity desired; 4. The Full (eight digit) Model Number of the unit. The model number will be found on a plate attached to the unit.



Look for this symbol. It means - ATTENTION! BECOME ALERT! A HAZARD TO OPERATOR, BYSTANDER, PROPERTY OR EQUIPMENT MAY EXIST.

NOMA Outdoor Products Incorporated

Caller 8000

Jackson, TN 38308-8000

Part No. 318349

0591

39" LAWN TRACTOR MODEL B3560-830

CHASSIS & HOOD ASSEMBLY

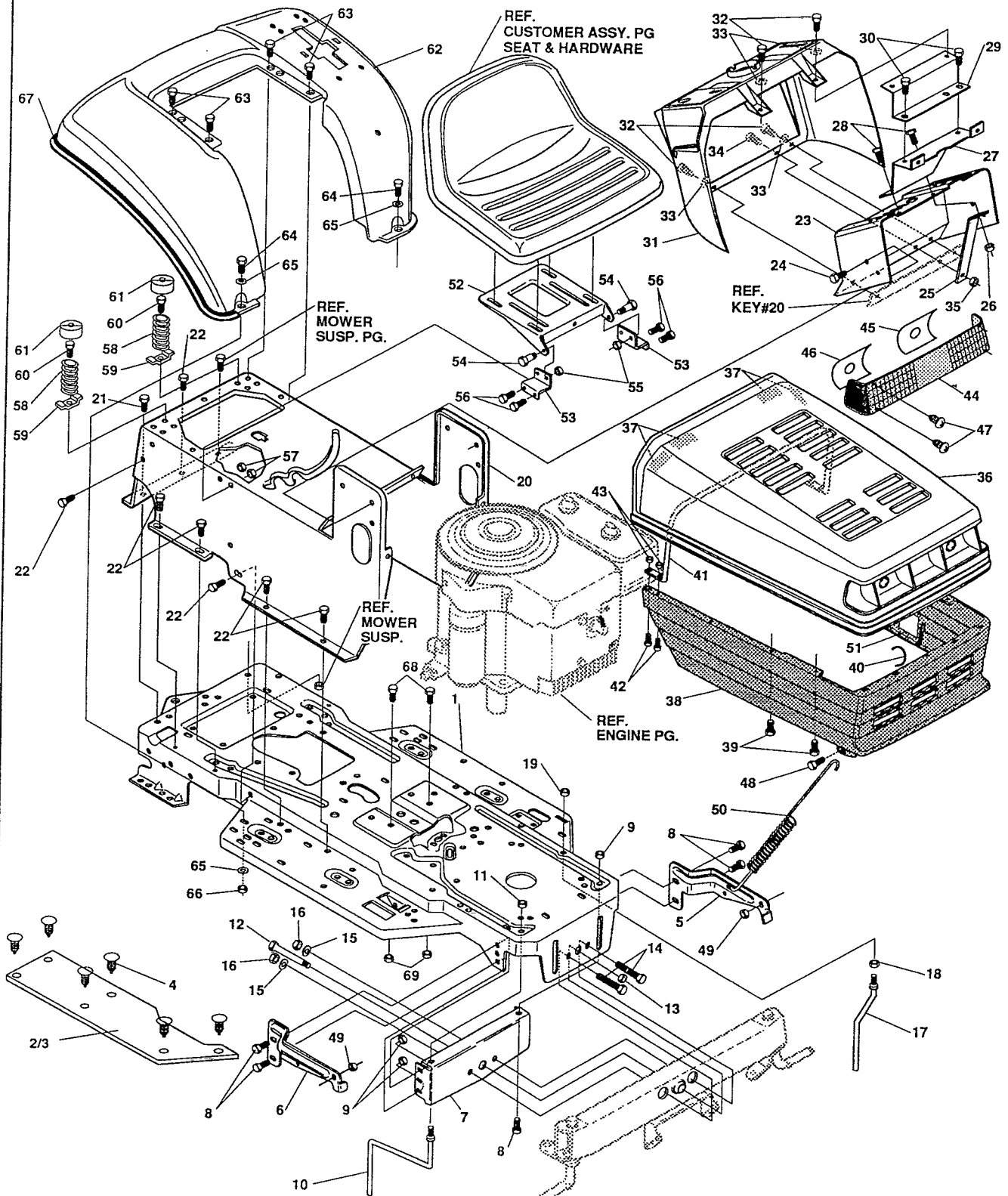

NOTE: ALWAYS USE ORIGINAL EQUIPMENT PARTS. Use of service/replacement parts other than original equipment parts may void your warranty.

REF. STEERING PG. FRONT AXLE ASSY.

ALL UNNUMBERED ITEMS ARE INTERCHANGABLE WITH OPPOSITE SIDE

316571D

39" LAWN TRACTOR MODEL B3560-830

key#	part#	description	qty.
1	317958	FRAME	1
2	310005	FOOTPAD,LH --	1
3	310006	FOOTPAD,RH --	1
4	309235	FASTENER, RATCHET -	12
5	9785	BRACKET,GRILLE LH	1
6	9784	BRACKET,GRILLE RH	1
7	56361	BRACKET, FRONT AXLE	1
8	56030	SCREW, 5/16-18X.75WDFLLK	5
9	55273	NUT, 5/16-18 HXWDFLLK	5
10	300440	GUIDE, BELT, RIDER	1
11	◇1498	NUT, 5/16-18 REGHEXCTRLK	1
12	58246	BOLT, .625X2.180 HSH 1/2-13	1
13	◇1500	NUT, 1/2-13 REGHCTRLK	1
14	◇122207	SCREW, 3/8-16X3.00 HHC	2
15	2483	WASHER, .39IDX1.25DX.07 BELLVIL	2
16	◇1499	NUT, 3/8-16 REGHXCTRLK	2
17	300635	GUIDE,SHORT BELT RIDER 15"WH --	1
18	◇124824	NUT, 5/16-18 HEXJAM	1
19	◇271190	NUT, 3/8-16 HEXKEPS	1
20	311242	CONSOLE	1
21	◇35497	SCREW, 5/16-18X .50 WAHHTAP	1
22	◇995346	SCREW, 1/4-20X .50 WAHHTAP	13
23	9132	SUPPORT, DASH	1
24	◇300303	SCREW, .25X.75X.75HHWAPLASTITE	2
25	9197	BRACE, DASH SUPT LOWER	1
26	◇1502	NUT, 1/4-20 REGHEXCTRLK	1
27	9744	BRKT, GAS TANK	1
28	◇995346	SCREW, 1/4-20X .50 WAHHTAP	2
29	9208	BRACE, DASH SUPT UPPER	1
30	◇995346	SCREW, 1/4-20X .50 WAHHTAP	2
31	305428	DASH	1
32	◇995346	SCREW, 1/4-20X .50 WAHHTAP	4
33	316868	WASHER,SHOULDER NYLON .255X.46	4
34	◇44811	SCREW, 1/4-20X .75 HXWATAP	1
35	◇1502	NUT, 1/4-20 REGHEXCTRLK	2
36	307035	HOOD	1
37	318197	PAD,ADHESIVE 1.00 X	4
38	303037	GRILLE,LWR	1
39	◇300302	SCREW, #10 X .50 HHTAPPST	4
40	310203	CLIP,HOG RING C-SHAPED	1
41	301425	BRACE,HOOD SUPPORT	1
42	◇301542	SCREW, 10-2451.00HWATAPBLKPHOS	4
43	◇271166	NUT, #10-24 HEXKEPS	1
44	302333	LENS, SMOKED W/TAB	1
45	301541	FOIL, REFLECTOR LENS LH	1
46	301540	FOIL, REFLECTOR LENS RH	1
47	◇57796	SCREW, #6 X .50 PLASTITE	4
48	56676	BOLT, .375X .580 HSH 5/16-18	2
49	◇1498	NUT, 5/16-18 REGHEXCTRLK	2
50	57478	SPRING, HOOD LATCH	2
51	301452	FOIL, HEAT REFLECTOR	1
52	307024	PLATE, SEAT	1
53	311249	BRACKET, SEAT SUPPORT	1
54	20507	BOLT, .437X .156 HSH 5/16-18	2
55	◇1498	NUT, 5/16-18 REGHEXCTRLK	2
56	◇120228	SCREW, 5/16-18X .63 HHC	4
57	◇1498	NUT, 5/16-18 REGHEXCTRLK	4
58	57153	SPRING,SEAT 2.63LG,1.49OD	2
59	1341	CLAMP,SPRING 1.17"ID ZPL	2
60	◇44811	SCREW, 1/4-20X .75 HXWATAP	2
61	56907	COVER,SEAT SPRING 1.5IDX1.0 --	2
62	307365	FENDER	1
63	◇995346	SCREW, 1/4-20X .50 WAHHTAP	4
64	◇122017	SCREW, 5/16-18X1.00 HHC	2
65	◇446363	WASHER, FLAT .375X .88X.082	4
66	◇1498	NUT, 5/16-18 REGHEXCTRLK	2
67	55021	TRIM,STRIP,BLACK	77.5"
68	180079	SCREW,5/16-18X1.00 HHC	2
69	1498	NUT, 5/16-18 REGHEXCTRLK	2
70	318348	OPERATOR'S MANUAL (NOT ILLUSTRATED)	1
71	318349	PARTS MANUAL (NOT ILLUSTRATED)	1

◇ Indicates STANDARD HARDWARE ITEMS.

39" LAWN TRACTOR MODEL B3560-830

MOWER SUSPENSION ASSEMBLY

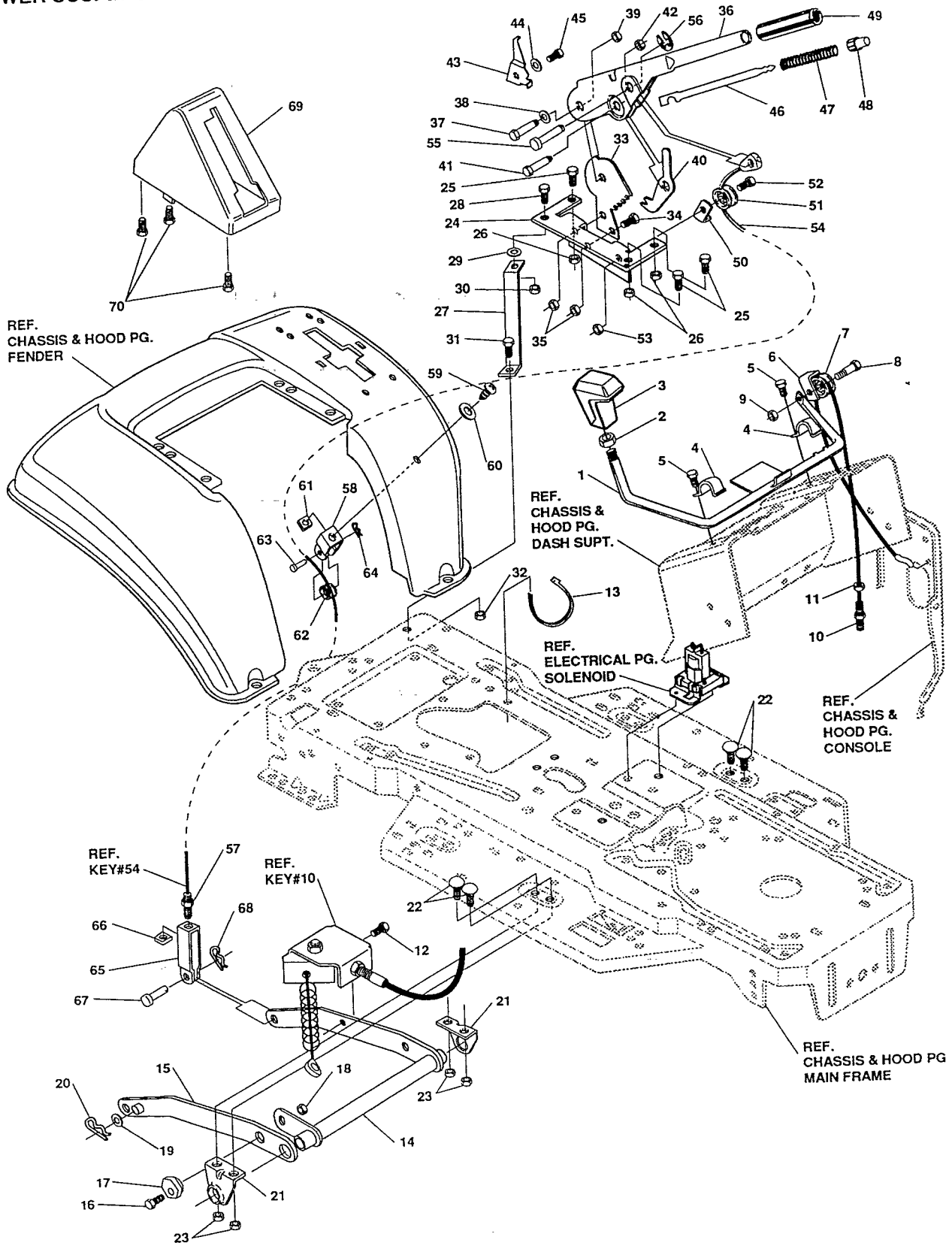

NOTE: ALWAYS USE ORIGINAL EQUIPMENT PARTS. Use of service/replacement parts other than original equipment parts may void your warranty.

ALL UNNUMBERED ITEMS ARE INTERCHANGABLE WITH OPPOSITE SIDE

315559B

Part No. 318349

39" LAWN TRACTOR MODEL B3560-830

key#	part#	description	qty.
1	9792	CLUTCH HANDLE ~	1
2	◇120238	NUT, 1/2-13 HEXJAM	1
3	304438	KNOB,SHIFT 1/2-13	1
4	9129	CLIP, RETAINING BRKT ~	2
5	◇995338	SCREW, 1/4-20X .63 WAHHTAP	2
6	1288	BRKT,CABLE RETAINER ~	1
7	39298	PULLEY, .906X.305 NYLON	1
8	57322	BOLT, .375X .375 HHSH 1/4-20 ~	1
9	◇1502	NUT, 1/4-20 REGHEXCTRLK	1
10	301491	ASSY,CL. CABLE	1
11	◇120613	NUT, 1/4-28 HJAM~	1
12	◇35498	SCREW, 5/16-18X .75 WAHHTAP	1
13	57444	TIE, CABLE BLACK NYLON 5.62	1
14	9185	ASSY,REAR LIFT	1
15	9186	ASSY.LINK,RIGHT SIDE	1
16	◇180079	SCREW, 5/16-18X1.00 HHC	1
17	58247	ADJUSTING NUT	1
18	◇1498	NUT, 5/16-18 REGHEXCTRLK~	1
19	◇120396	WASHER, FLAT .531X1.06X.095	2
20	8260	PIN, HAIR .091 DIA X1.66LG	2
21	9117	BRKT,REAR,HANG,SUSP.	2
22	126211	BOLT, 5/16-18X .63 CARR	4
23	◇1498	NUT, 5/16-18 REGHEXCTRLK	4
24	58333	BRACKET,HGT/ADJUST SUPPORT	1
25	180077	SCREW, 5/16-18X .75 HHC	3
26	◇1498	NUT, 5/16-18 REGHEXCTRLK	3
27	307367	BRACE, FENDER	1
28	◇180079	SCREW, 5/16-18X1.00 HHC	1
29	◇45602	WASHER, FLAT .333X .87X.119	1
30	◇1498	NUT, 5/16-18 REGHEXCTRLK	1
31	◇180079	SCREW, 5/16-18X1.00 HHC	1
32	◇1498	NUT, 5/16-18 REGHEXCTRLK	1
33	301238	QUADRANT,HEIGHT ADJUST	1
34	◇180077	SCREW, 5/16-18X .75 HHC ~	2
35	◇1498	NUT, 5/16-18 REGHEXCTRLK	2
36	9788	HANDLE,LIFT SHORT	1
37	300171	BOLT, .500X .270 HHSH 5/16-18	1
38	996418	WASHER, FLAT .506X .75X.024	1
39	◇44108	NUT, 5/16-18 HWDFLCTRLK	1
40	301239	PAWL, HEIGHT ADJUST	1
41	300171	BOLT, .500X .270 HHSH 5/16-18	1
42	◇44108	NUT, 5/16-18 HWDFLCTRLK	1
43	9435	POINTER	1
44	138479	WASHER, EXLK .195X.41X.03 ~	1
45	◇35287	SCREW, #8-32X .38 HHWATAP	1
46	303027	ROD,ACTUATOR-SHORT	1
47	58326	SPRING, HEIGHT ADJUST	1
48	58325	KNOB, HGT ADJ PUSH BUTTON	1
49	58329	GRIP .750 OD W/ HOLE	1
50	9149	BRKT, CABLE RETAINER	1
51	39298	PULLEY, .906X.305 NYLON	1
52	58336	BOLT, .375X .375 HHSH 1/4-20	1
53	◇1502	NUT, 1/4-20 REGHEXCTRLK	1
54	300341	CABLE, LIFT 21.70 F-5 20X8-8	1
55	300310	PIN,CLEVIS .310DIA+.475LG	1
56	300311	RING, RET E .31X.24	1
57	◇120375	NUT, 1/4-20 REGHEX	1
58	9239	CLEVIS ~	1
59	◇439455	SCREW, 5/16-18X .56PHPNMA BKPH	1
60	301551	WASHER, .344IDX1.50DX.09 CU BPH	1
61	◇120373	NUT, 5/16-18 SQ	1
62	39298	PULLEY, .906X.305 NYLON	1
63	300317	PIN, CLEVIS .38 DIA X1.00 LG ~	1
64	8260	PIN, HAIR .091 DIA X1.66LG	1
65	9405	CLEVIS, LIFT CABLE	1
66	◇120372	NUT, 1/4-20 REGSQ ~	1
67	39522	PIN, CLEVIS .312 X .812	1
68	121222	PIN, COTTER .090/.086X.75LG	1
69	300335	LIFT COVER-39" F5 ~	1
70	◇300340	SCREW, #10 X .75 HHPLAST ~	3

◇ STANDARD HARDWARE ITEMS

39" LAWN TRACTOR MODEL B3560-830

STEERING ASSEMBLY

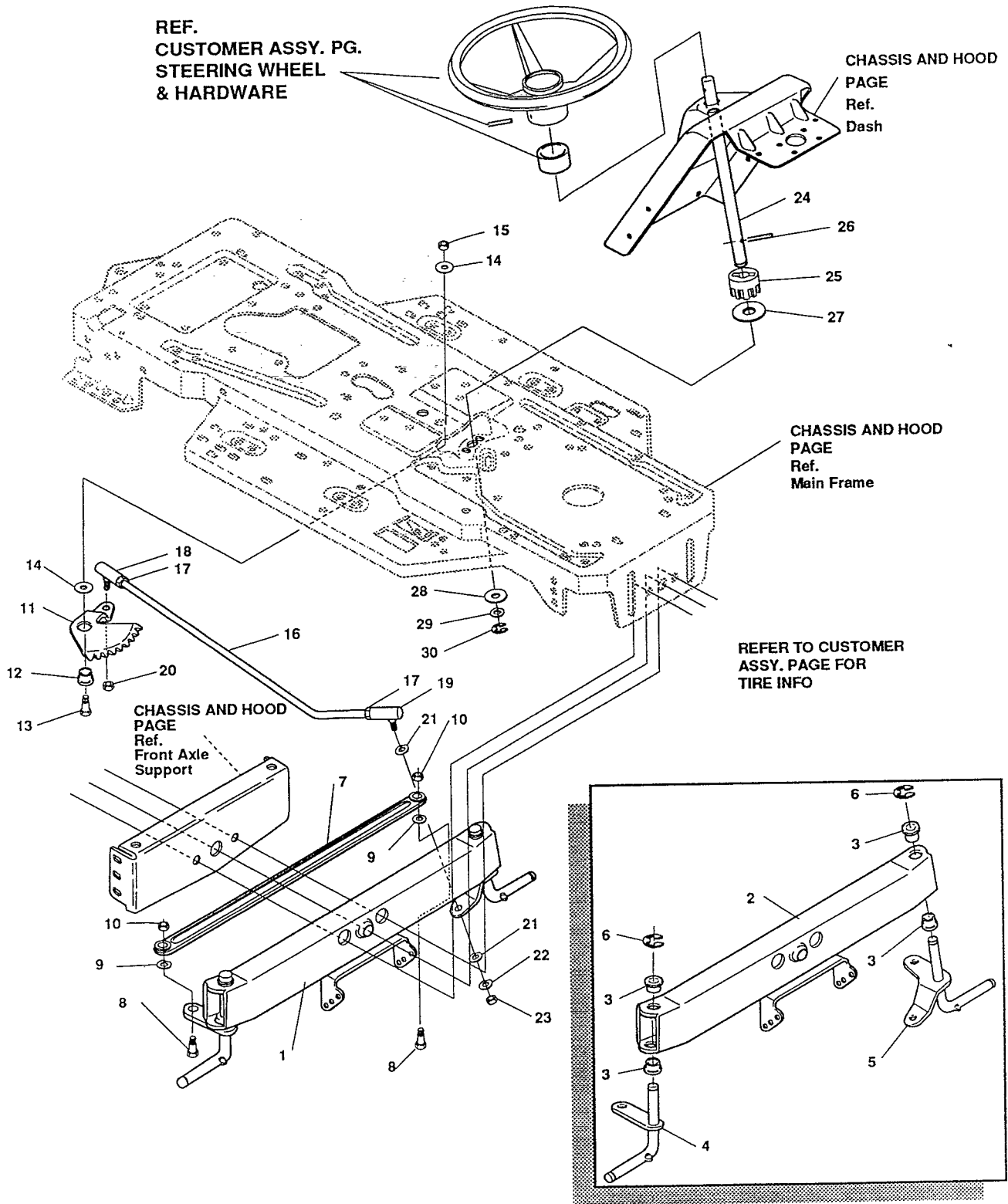

ALL UNNUMBERED ITEMS ARE INTERCHANGABLE WITH OPPOSITE SIDE

NOTE: ALWAYS USE ORIGINAL EQUIPMENT PARTS. Use of service/replacement parts other than original equipment parts may void your warranty.

315650C

39" LAWN TRACTOR MODEL B3560-830

key#	part#	description	qty.
1	*	ASSY,AXLE FRONT 4/WS SUSP	1
2	300272	AXLE, FRONT	1
3	52407	SPINDLE BEARING	4
4	302926	ASSY,SPINDLE RH	1
5	315886	ASSY,SPINDLE LH	1
6	36625	RING, RETEX .57X.05TRU5133-75	2
7	304590	TIE ROD ASSY 19.81LG W-SECTION	1
8	180128	SCREW, 3/8-16X1.75 HHC	2
9	120382	WASHER, REGSPTLK.393X.68X.10	2
10	1499	NUT, 3/8-16 REGHEX	2
11	58289	SECTOR, STEERING LF	1
12	52406	BRNG,FL ECC.510IDX .998ODX .56	1
13	180177	SCREW, 1/2-13X1.50 HHC	1
14	22265	WASHER, FLAT .515X1.38X.119	2
15	1500	NUT, 1/2-13 REGHCTRLK	1
16	58291	STEERING LINK	1
17	124925	NUT, 3/8-24 REGHEXJAM	2
18	57158	BALL JOINT 3/8 THD SHORT STUD	1
19	21275	BALL JOINT 3/8 TH'D LONG STUD	1
20	46692	NUT, 3/8-24 WDFLHLK WHIZ	1
21	120396	WASHER, FLAT .531X1.06X.095	2
22	120382	WASHER, REGSPTLK.393X.68X.10	1
23	120369	NUT, 3/8-24 REGHEX	1
24	58243	SHAFT, STEERING LF	1
25	58244	PINION, STEERING LF	1
26	58274	PIN,DOWEL .2500 OD+1.75LG	1
27	301410	BRNG, FL .752IDX1.061ODX .24	1
28	301398	WASHER, FORMED1.135X1.53X.12	1
29	21682	WASHER, FLAT .765X1.25X.042 PL	1
30	36625	RING, RETEX .57X.05TRU5133-75	1

* Order Individual Parts.

39" LAWN TRACTOR MODEL B3560-830

MOTION DRIVE ASSEMBLY

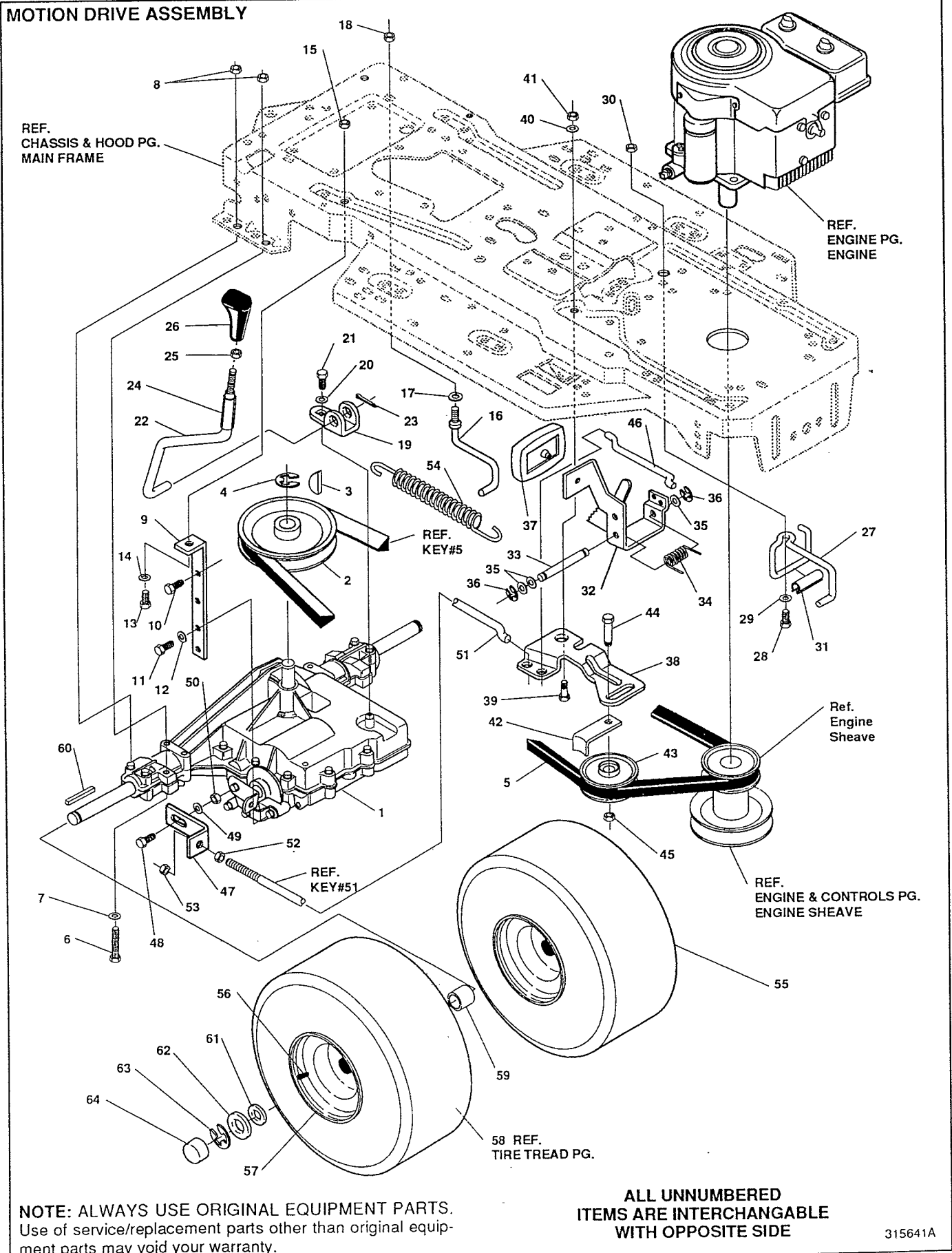

NOTE: ALWAYS USE ORIGINAL EQUIPMENT PARTS. Use of service/replacement parts other than original equipment parts may void your warranty.

ALL UNNUMBERED ITEMS ARE INTERCHANGABLE WITH OPPOSITE SIDE

315641A

39" LAWN TRACTOR MODEL B3560-830

key#	part#	description	qty.
1	4360-23 TRANSAXLE	FOOTE 4360-5 (CONTACT NEAREST DEALER)	1
2	302745	PULLEY,V 4L 6.60 OD	1
3	3021	KEY, WDRF 606 .750X.187X.312	1
4	22053	RING, RETEX .58X.04TRU5100-62	1
5	57214	BELT, V 4L 84.75	1
6	180112	SCREW, 5/16-18X2.75 HHC GR5	4
7	120393	WASHER, FLAT .344X .69X.065	4
8	1498	NUT, 5/16-18 REGHEXCTRLK	4
9	12632	STABILIZER BRKT P920,F4150	1
10	◇ 50947	SCREW, 3/8-16X1.25 WAHHTAP	1
11	◇ 35498	SCREW, 5/16-18X .75 WAHHTAP	1
12	◇ 120638	WASHER, HVSP TLK .328X.60X.09	1
13	◇ 122017	SCREW, 5/16-18X1.00 HHC GR2	1
14	◇ 120393	WASHER, FLAT .344X .69X.065	1
15	◇ 1498	NUT, 5/16-18 REGHEXCTRLK	1
16	57259	GUIDE, BELT 5/16-18THD	1
17	◇ 138538	WASHER, REGINTLK.320X.61X.03	1
18	◇ 1498	NUT, 5/16-18 REGHEXCTRLK	1
19	57480	BRKT,SHIFT P920-5/F4360-5&3 955	1
20	57157	WASHER, .750X.250 SP-TRANSAXLE	1
21	56255	CREW, 1/4-28X .75 NYLHHCGR8	1
22	302743	LEVER,SHIFT FOOT 4360-5&6 LF	1
23	137185	PIN, COTTER .125 DIA X1.00LG	1
24	302445	TUBE,CLEAR PLASTIC	1
25	◇ 120238	NUT, 1/2-13 HEXJAM	1
26	304438	KNOB,SHIFT NOMA 1/2-13 BLK	1
27	58356	GUIDE-BELT/DRAGLINK	1
28	◇ 180079	SCREW, 5/16-18X1.00 HHC GR5	1
29	◇ 45602	WASHER, FLAT .333X .87X.119	1
30	◇ 1498	NUT, 5/16-18 REGHEXCTRLK	1
31	303278	PLASTIC EXTRUSION-BELT GUIDE	1
32	300308	PEDAL ASSY,BRAKE/CLUTCH LF	1
33	57196	ROD,PIVOT .50 OD+4.44LG ZN PL	1
34	57847	SPRING, BRAKE PEDAL	1
35	2968	WASHER, FLAT .504X .75X.059	3
36	20864	RING, RET E .39X.04TRU5133-50	2
37	48160	PAD, CLUTCH BRAKE W/PRINTING	1
38	300154	ARM,IDLER TRACTION DR. LF	1
39	300793	BOLT, .625X .135 HSSH 5/16-18	1
40	◇ 45602	WASHER, FLAT .333X .87X.119	1
41	◇ 1498	NUT, 5/16-18 REGHEXCTRLK	1
42	39659	RETAINER, STRAP BELT	1
43	35374	PULLEY, IDLER V4L 3.06X .62	1
44	45892	BOLT, 3/8-16X1.50 CARR GR2	1
45	◇ 1499	NUT, 3/8-16 REGHXCTRLK	1
46	57204	ROD, CLUTCH LF	1
47	57217	BRACKET, BRAKE ROD	1
48	20507	BOLT, .437X .156 HSSH 5/16-18	1
49	◇ 45602	WASHER, FLAT .333X .87X.119	1
50	◇ 1498	NUT, 5/16-18 REGHEXCTRLK	1
51	57203	ROD, BRAKE LT 920 LF 22.25	1
52	◇ 271184	NUT, 5/16-18 HEXKEPS	1
53	◇ 1498	NUT, 5/16-18 REGHEXCTRLK	1
54	56359	SPRING, CLUTCH .113X.750X8.75	1
55	*	TIRE & RIM, PU 20X8.00-8TURWHI	2
56	24167	VALVE STEM	1
57	41105	WHEEL	1
58		REFER TO TIRE TREAD PAGE	
59	57479	SPACER, .75 X 1.25 X 1.32	2
60	39628	KEY, SQUARE .187SQX2.50LG	2
61	642	WASHER, FLAT .755X1.31X.075	4
62	42815	WASHER, FLAT .755X1.53X.07	2
63	36625	RING, RETEX .57X.05TRU5133-75	2
64	40394	CAP, 1.500ID X 7/8LG HUB	2

* Order Individual Parts.

◇ Indicates STANDARD HARDWARE ITEMS.

39" LAWN TRACTOR MODEL B3560-830

ENGINE & CONTROL ASSEMBLY

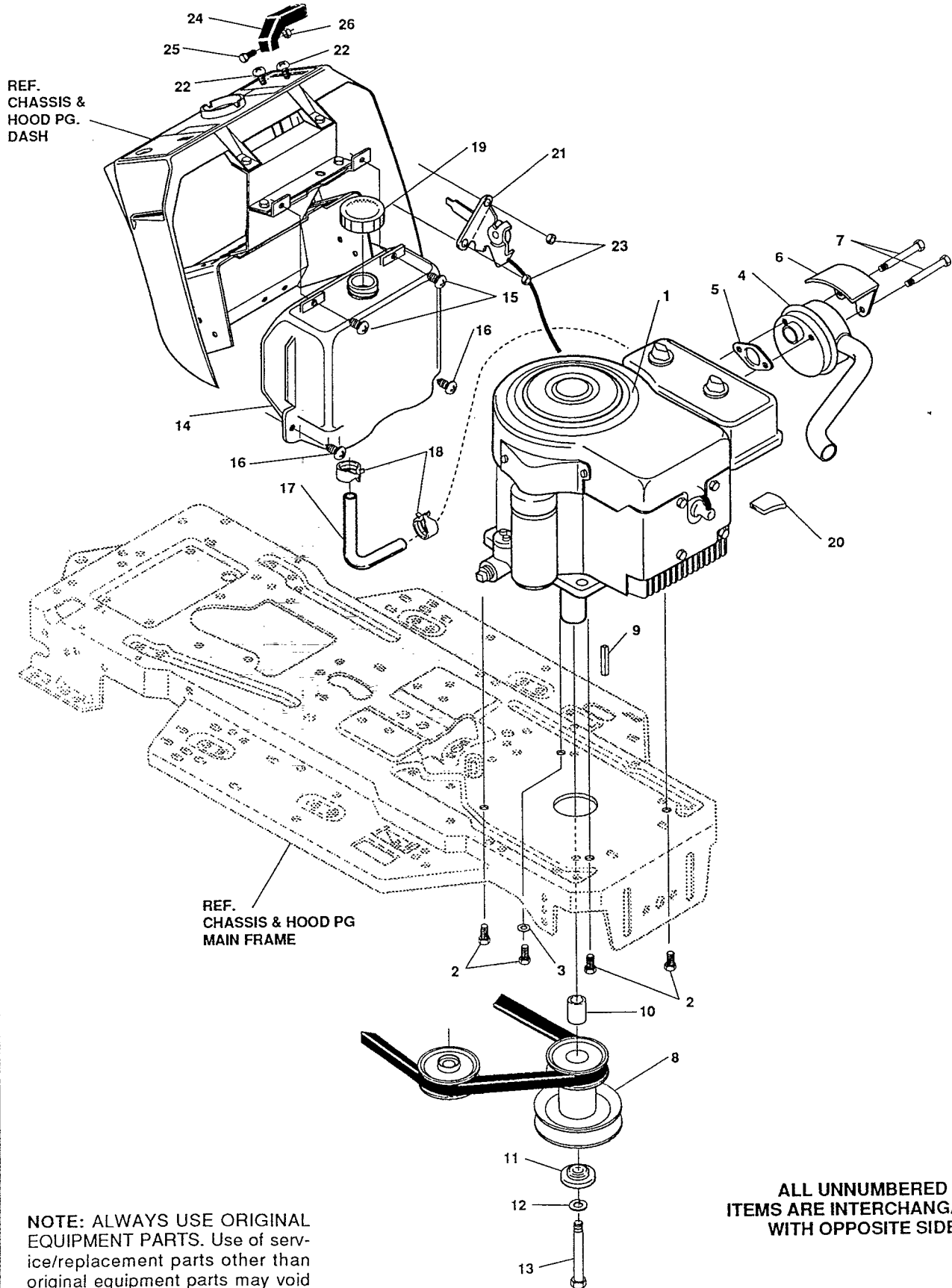

**ALL UNNUMBERED
ITEMS ARE INTERCHANGABLE
WITH OPPOSITE SIDE**

**NOTE: ALWAYS USE ORIGINAL
EQUIPMENT PARTS. Use of serv-
ice/replacement parts other than
original equipment parts may void
your warranty.**

315584B

39" LAWN TRACTOR MODEL B3560-830

key#	part#	description	qty.
1	ENGINE	12 HP B&S I/C ECONO (SEE ENGINE MANUAL)	1
2	◇50947	SCREW, 3/8-16X1.25 WAHHTAP	4
3	138489	WASHER, EXLK .384X.69X.04	1
4	305367	MUFFLER-LO TONE NELSON EXPORT	1
5	46708	GASKET, MUFFLER	1
6	54767	SHIELD, HEAT, FOR ROUND MUFFLER	1
7	◇173063	SCREW, 5/16-18X3.50 HHC	2
8	58361	PULLEY ASSY, 4.75OFFS 5.5DIA	1
9	57791	KEY, SQUARE .250SQX5.00LG	1
10	304246	SPACER, 1.01X1.484 ENGIN PULLEY >	1
11	56431	WASHER, .980IDX1.38ODX.437PILOT	1
12	120383	WASHER, REGSPTLK.459X.78X.12 —	1
13	◇428644	SCREW, 7/16-20X5.00 HHC —	1
14	314991	TANK, FUEL 2-GAL —	1
15	◇300303	SCREW, .25X.75X.75HHWAPLASTITE	2
16	◇995346	SCREW, 1/4-20X .50 WAHHTAP	2
17	47452	GAS LINE .25ID	14"
18	48672	CLAMP, FUEL LINE	2
19	300304	CAP, FUEL - 2.0 THROAT	1
20	302967	ENGINE SPEED REDUCER	1
21	303159	THROTTLE, CONTROL	1
22	◇159943	SCREW, 10-24X .63PHPNMA —	2
23	◇271166	NUT, #10-24 HEXKEPS	2
24	300508	KNOB, THROTTLE CONTROL HANDGRIP	1
25	◇159585	SCREW, #8-32X .38 PHPNMA	1
26	◇120622	NUT, #8-32 REGHX	1

◇ Indicates STANDARD HARDWARE ITEMS.

39" LAWN TRACTOR MODEL B3560-830

PRE-PAINTED DECK ASSEMBLY

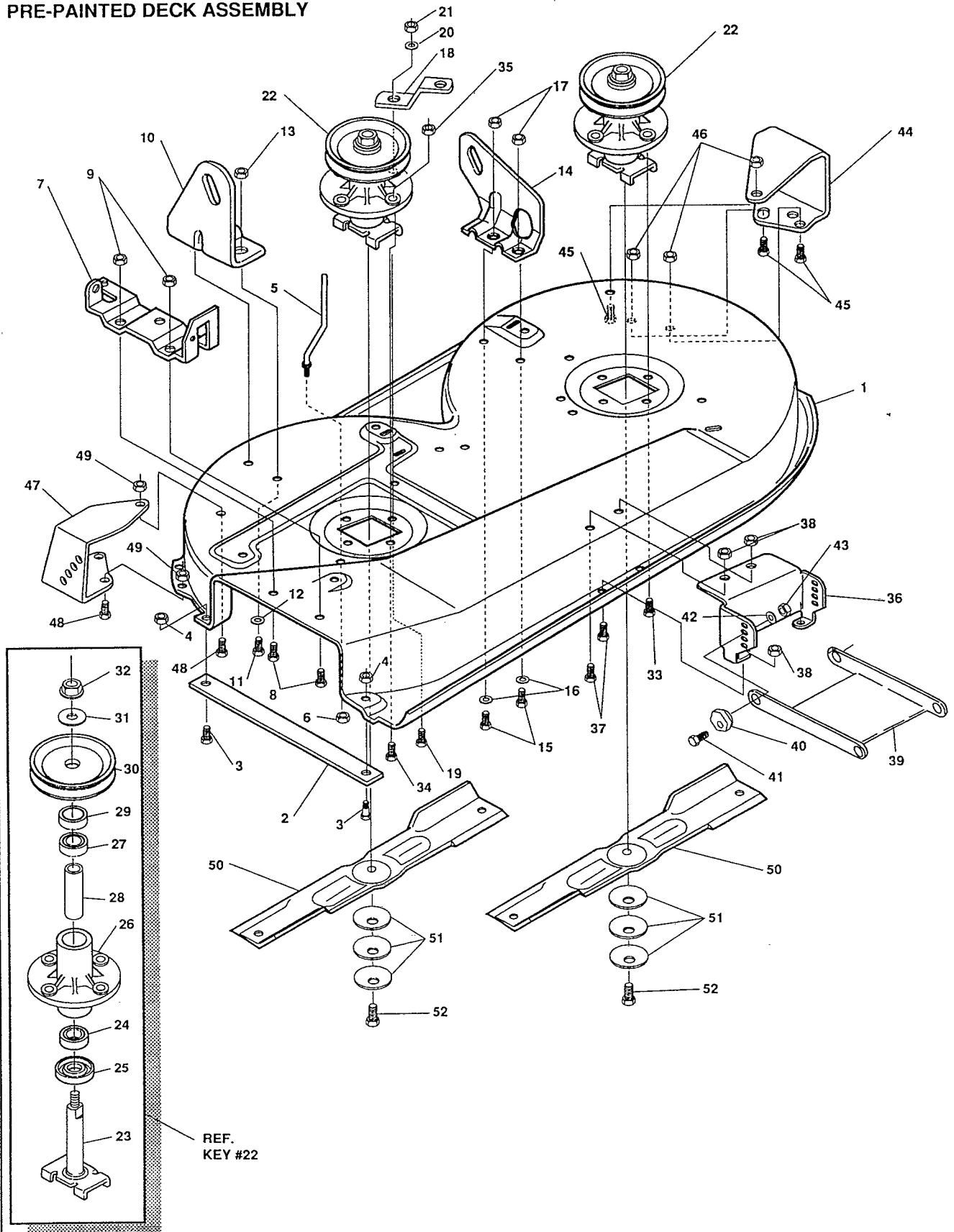

NOTE: ALWAYS USE ORIGINAL EQUIPMENT PARTS. Use of service/replacement parts other than original equipment parts may void your warranty.

ALL UNNUMBERED ITEMS ARE INTERCHANGABLE WITH OPPOSITE SIDE

316186A

39" LAWN TRACTOR MODEL B3560-830

key#	part#	description	qty.
1	317325	DECK,39"SD MOWER	1
2	57314	BAR, SKID	1
3	126216	BOLT, 5/16-18X .75 CARR	1
4	◇1498	NUT, 5/16-18 REGHEXCTRLK	1
5	57318	GUIDE, BELT 5/16-18 THD	1
6	◇1498	NUT, 5/16-18 REGHEXCTRLK	1
7	57360	BRACKET, CHUTE	1
8	◇120834	SCREW, 5/16-18X .50 HHC	2
9	◇1498	NUT, 5/16-18 REGHEXCTRLK	2
10	58250	LIFT BRACKET, REAR,RH	1
11	◇180077	SCREW, 5/16-18X .75 HHC	2
12	120393	WASHER, FLAT .344X .69X.065	2
13	◇1498	NUT, 5/16-18 REGHEXCTRLK	2
14	58251	BRACKET,DECK LIFTREAR LH	1
15	◇180077	SCREW, 5/16-18X .75 HHC	2
16	120393	WASHER, FLAT .344X .69X.065	2
17	◇1498	NUT, 5/16-18 REGHEXCTRLK	2
18	315302	BRACKET, IDLER SUPPORT	1
19	◇300345	SCREW, 5/16-18X1.38 WATAP	1
20	120393	WASHER, FLAT .344X .69X.065	1
21	◇1498	NUT, 5/16-18 REGHEXCTRLK	1
22	56424	QUILL ASSY, 36/39/40/43	2
23	56425	SHAFT/SADDLE 36"	1
24	49562	BRNG, BALL	1
25	50616	DUST SHIELD	1
26	55547	QUILL CASTING	1
27	49562	BRNG, BALL	1
28	50818	SPACER,3.797LGX.669IDX.88OD	1
29	51449	SPACER, 438LGX.932ODX.672ID-PM	1
30	56390	PULLEY,26/36" QUILL	1
31	56365	SPECIAL WASHER	1
32	◇1282	NUT, 7/16-20 WDFLLK	1
33	◇50634	SCREW, 5/16-18X .88 WAHTAP	6
34	◇300345	SCREW, 5/16-18X1.38 WATAP	1
35	◇1498	NUT, 5/16-18 REGHEXCTRLK	1
36	58315	LIFT SUPPORT FRONT DECK	1
37	◇180075	SCREW, 5/16-18X .63 HHC	4
38	◇1498	NUT, 5/16-18 REGHEXCTRLK	4
39	58305	LINK BRACKET,DECK FR	1
40	58247	ADJUSTING NUT	2
41	◇122017	SCREW, 5/16-18X1.00 HHC	2
42	35214	WASHER, FLAT .328X1.06X.062	2
43	◇1498	NUT, 5/16-18 REGHEXCTRLK	2
44	300103	WHEEL BRKT, LH	1
45	◇180075	SCREW, 5/16-18X .63 HHC	3
46	◇1498	NUT, 5/16-18 REGHEXCTRLK	3
47	300102	WHEEL BRKT, RH	1
48	◇180075	SCREW, 5/16-18X .63 HHC	3
49	◇1498	NUT, 5/16-18 REGHEXCTRLK	3
50	57299	BLADE, 39" STD-LIFT 19.5 309069	2
51	2483	WASHER, .39IDX1.25DX.07 BELLVIL	6
52	◇39573	SCREW, 3/8-24X1.00 NYLHHC	2

◇ Indicates STANDARD HARDWARE ITEMS

39" LAWN TRACTOR MODEL B3560-830

FINAL DECK ASSEMBLY

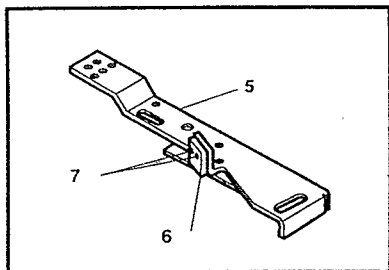

SEE DWG. 316186 FOR PART ASSY OF PAINTED DECK

REF KEY #4

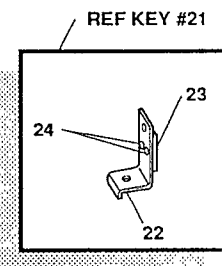

REF KEY #21

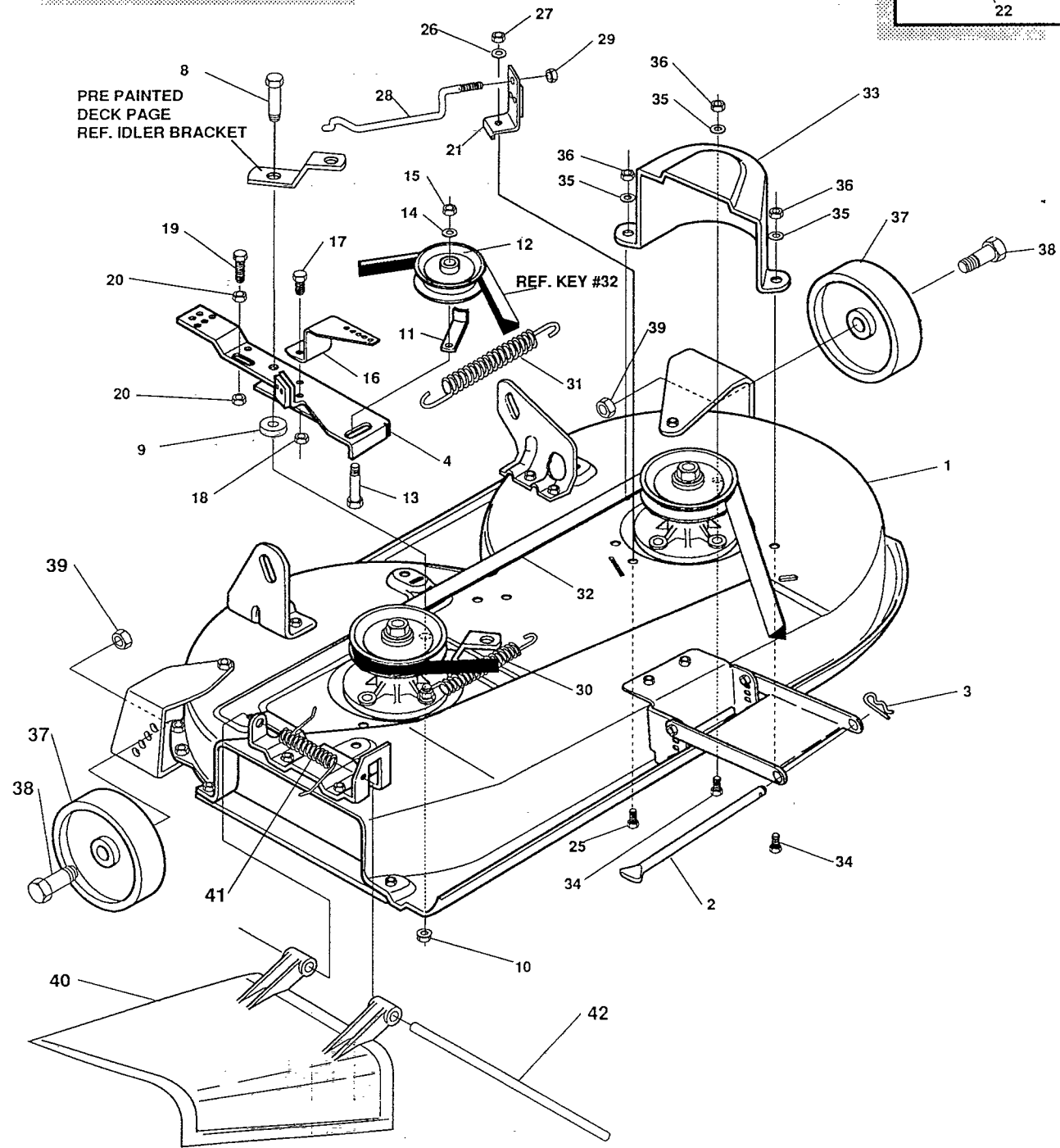

NOTE: ALWAYS USE ORIGINAL EQUIPMENT PARTS.
Use of service/replacement parts other than original equipment parts may void your warranty.

ALL UNNUMBERED ITEMS ARE INTERCHANGABLE WITH OPPOSITE SIDE

316188A

39" LAWN TRACTOR MODEL B3560-830

key#	part#	description	qty.
1	*	DECK ASSY.	1
2	58306	ROD, DECK HITCH	1
3	8260	PIN, HAIR .091 DIA X 1.66	1
4	300491	BRACKET, IDLER ARM/BRAKE	1
5	9282	IDLER ARM -	1
6	306973	BRAKE PAD	1
7	135624	RIVET, TRSET .185 DIA X .41 -	2
8	300180	BOLT, .50 X 1.88 HSSH 3/8-16	1
9	◇996416	WASHER, FLAT .391 X 1.00 X .125 -	1
10	◇45171	NUT, 3/8-16 HWDFL WHIZ NUT	1
11	1346	BELT RETAINER 2.55 OD	1
12	303030	PULLEY, IDLER BFF 4.00 DIA	1
13	57325	BOLT, 3/8-16 X 2.00 CARR	1
14	◇120382	WASHER, REGSPTLK.393 X .68 X .10 -	1
15	◇120377	NUT, 3/8-16 REGHX	1
16	9401	BRACKET, EXTENSION IDLER	1
17	◇180077	SCREW, 5/16-18 X .75 HHC -	1
18	◇1498	NUT, 5/16-18 REGHEXCTRLK	1
19	◇121954	SCREW, 1/4-20 X 2.00 HHC	1
20	◇271172	NUT, 1/4-20 REGHEXKEPS	2
21	303247	ASSY. BLADE BRAKE 36,39,45	1
22	12542	BRAKE ARM -	1
23	306973	BRAKE PAD	1
24	135624	RIVET, TRSET .185 DIA X .41 -	2
25	◇120228	SCREW, 5/16-18 X .63 HHC	1
26	◇120393	WASHER, FLAT .344 X .69 X .065	1
27	◇1498	NUT, 5/16-18 REGHEXCTRLK	1
28	300316	ROD, BRAKE RELEASE -	1
29	◇1502	NUT, 1/4-20 REGHEXCTRLK	1
30	35410	SPRING .071 X .62 X 4.37	1
31	300473	SPRING, TENSION 7.52 LG + 17 LB/IN	1
32	300680	BELT, V 5L 77.75 KEVLAR	1
33	302833	GUARD, BELT LH	1
34	◇120228	SCREW, 5/16-18 X .63 HHC	3
35	◇120393	WASHER, FLAT .344 X .69 X .065	3
36	◇1498	NUT, 5/16-18 REGHEXCTRLK	3
37	52584	WHEEL, SD 6.00 O D X 1.38 W D	2
38	23763	BOLT, .500 X 1.390 HSSH 3/8-16	2
39	◇1499	NUT, 3/8-16 REGHXCTRLK	2
40	57818	CHUTE-36SD,39SD,45SD	1
41	314975	SPRING, TORSION -	1
42	57317	PIVOT ROD, CHUTE	1

* Order Individual Parts.

◇ STANDARD HARDWARE ITEMS

39" LAWN TRACTOR MODEL B3560-830

ELECTRICAL ASSEMBLY

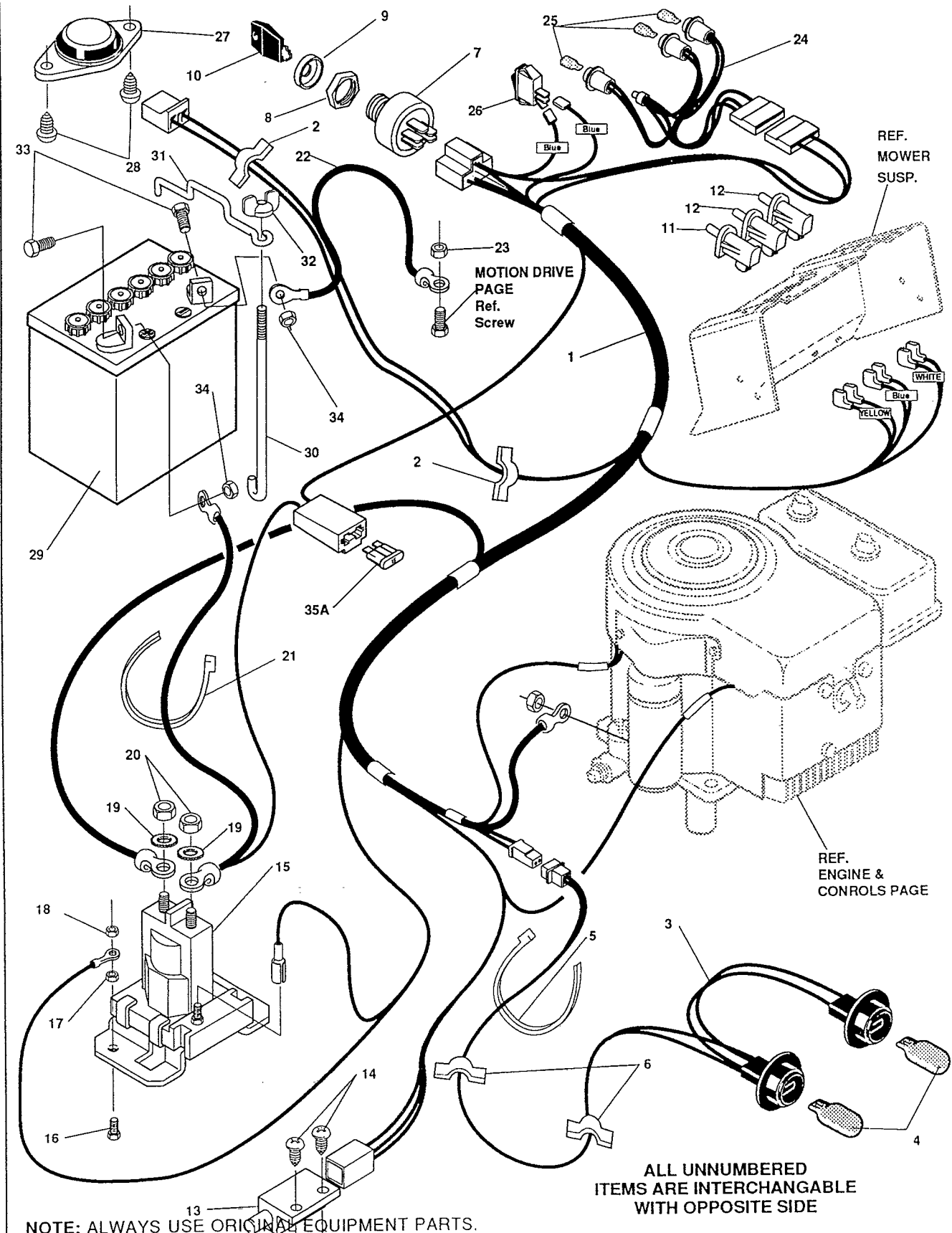

NOTE: ALWAYS USE ORIGINAL EQUIPMENT PARTS.
Use of service/replacement parts other than original equipment parts may void your warranty.

**ALL UNNUMBERED
ITEMS ARE INTERCHANGABLE
WITH OPPOSITE SIDE**

315589A

39" LAWN TRACTOR MODEL B3560-830

key#	part#	description	qty.
1	300331	WIRE HARNESS GPWR 12B&S SUSP	1
2	41482	CLIP,1.380LG .255ID PRESS WIRE	2
3	303064	ASSY,LIGHT WIRE-1/4 TURN	1
4	52572	BULB, HEADLAMP	2
5	57444	TIE, CABLE BLACK	1
6	41482	CLIP,1.380LG .255ID PRESS WIRE	2
7	300295	SWITCH, IGNITION W/O LIGHTS	1
8	◇300193	NUT, 5/8-32 IGN SWIT	1
9	300194	BOOT,SWITCH	1
10	300626	KEY, IGNITION SWITCH	1
11	300220	SWITCH,SNAPMNT	1
12	58277	SWITCH,SNAPMNT NC .055/.166	2
13	57476	SWITCH,SCR MNT DP NC	1
14	◇57220	SCREW, #12 X .50 PHPNHTAP	2
15	53716	SOLENOID, NEW CLUM	1
16	◇187745	SCREW, 1/4-20X .75 HXSEMMA	2
17	◇1502	NUT, 1/4-20 REGHEXCTRLK	2
18	◇271172	NUT, 1/4-20 REGHEXKEPS	1
19	138485	WASHER, EXLK .320X.61X.03	2
20	◇120368	NUT, 5/16-24 REGHEX	2
21	57444	TIE, CABLE BLACK NYLON 5.62	1
22	55511	WIRE, GROUND, 12.5"	1
23	◇271184	NUT, 5/16-18 HEXKEPS	1
24	300965	LIGHT HARNESS 3-IL CHG,MWR,CL	1
25	57769	BULB, INDICATOR	3
26	300334	LIGHT SWITCH ON/OFF	1
27	57547	SWITCH, SEAT	1
28	◇160505	SCREW, 1/4-20X .38PHPNHMA	2
29	302257	BATTERY 12V 7 PLATE/	1
30	57551	ROD, BATTERY	1
31	57552	ROD, BATTERY, TOP	1
32	310067	SMALL PLASTIC WING NUT 1/4-20	1
33	◇120854	SCREW, 1/4-20X .63 HHC	2
34	◇271172	NUT, 1/4-20 REGHEXKEPS	2
35A	** 302031	FUSE,15 AMP SPADE TYPE	1
35B	** 49211	FUSE,15 AMP CLYRINDRICAL TYPE	1

◇STANDARD HARDWARE ITEMS

**Cylindrical or Spade type fuses are included with the wire harness.

39" LAWN TRACTOR MODEL B3560-830

DECALS

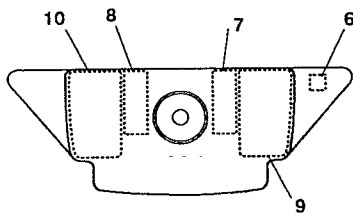
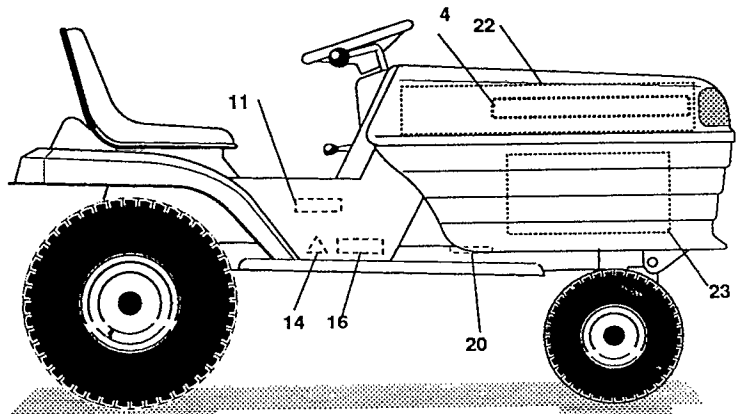
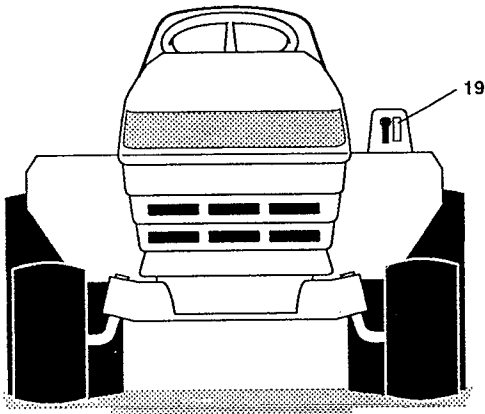

DASH DECALS

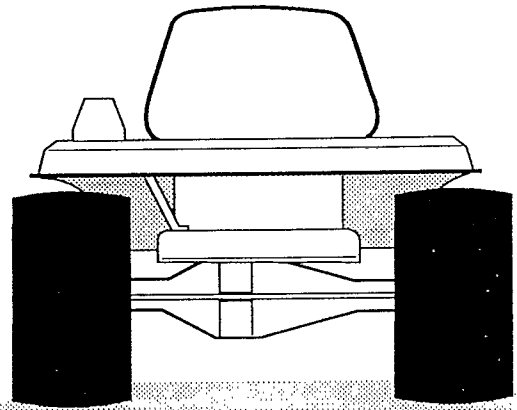
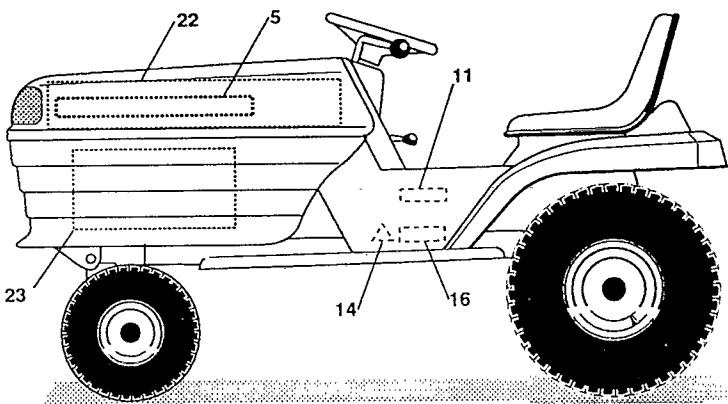
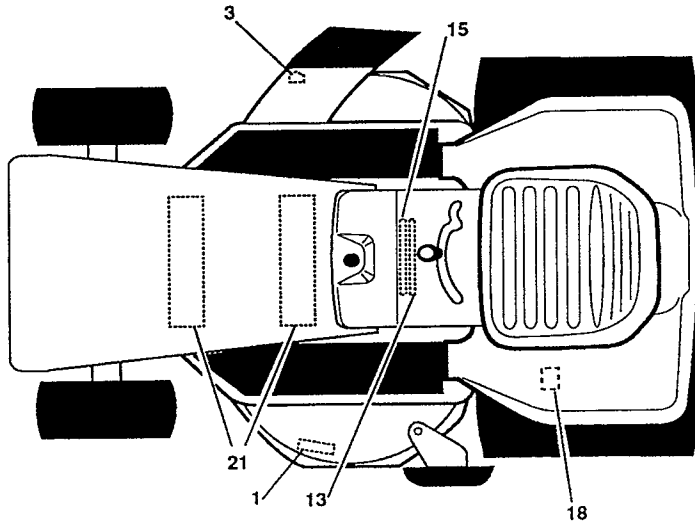

NOTE: ALWAYS USE ORIGINAL EQUIPMENT PARTS.
Use of service/replacement parts other than original equipment parts may void your warranty.

**ALL UNNUMBERED
ITEMS ARE INTERCHANGABLE
WITH OPPOSITE SIDE**

317763A

39" LAWN TRACTOR MODEL B3560-830

KEY#	PART#	DESCRIPTION	QTY.
1	68249	DECAL,NO STEP	1
2		REFERENCE ONLY	1
3	315514	DECAL, CUT-HAND WARNING LABEL	1
4	317738	DECAL, 3912 SOLIFER RH	1
5	317739	DECAL, 3912 SOLIFER LH	1
6	68900	DECAL,BLADE ENGAGE EUROPE	1
7	300445	DECAL,DASH RH TRANSLUCENT	1
8	302049	DECAL, DASH LH PLAIN	1
9	305766	DECAL,DASH,RH IGN	1
10	305767	DECAL,DASH,LH	1
11	300442	NAMEPLATE, 12/39 WHITE	2
12	...	REFERENCE ONLY	1
13	301104	DECAL, CONSOLE TOP SHIFT 5-SP	1
14	305770	DECAL,CAUTION TRIANGLE EUROPE	2
15	307383	DECAL,INSTR. CONSOLE TOP ENGL	1
16	310553	DECAL,DANGER ENGLISH	2
17		REFERENCE ONLY	1
18	68901	DECAL,BLADE HEIGHT ADJ. EUROPE	1
19	301897	DECAL, LIFT DECK BLADE HEIGHT	1
20	68903	DECAL,BRAKE/CLUTCH EUROPE	1
21	305602	FOAM HOOD 4X15	2
22	305603	PAD, 18 X 6 FOAM HOOD	2
23	305604	FOAM,HOOD 7X12	2

39" LAWN TRACTOR MODEL B3560-830

CUSTOMER ASSEMBLY

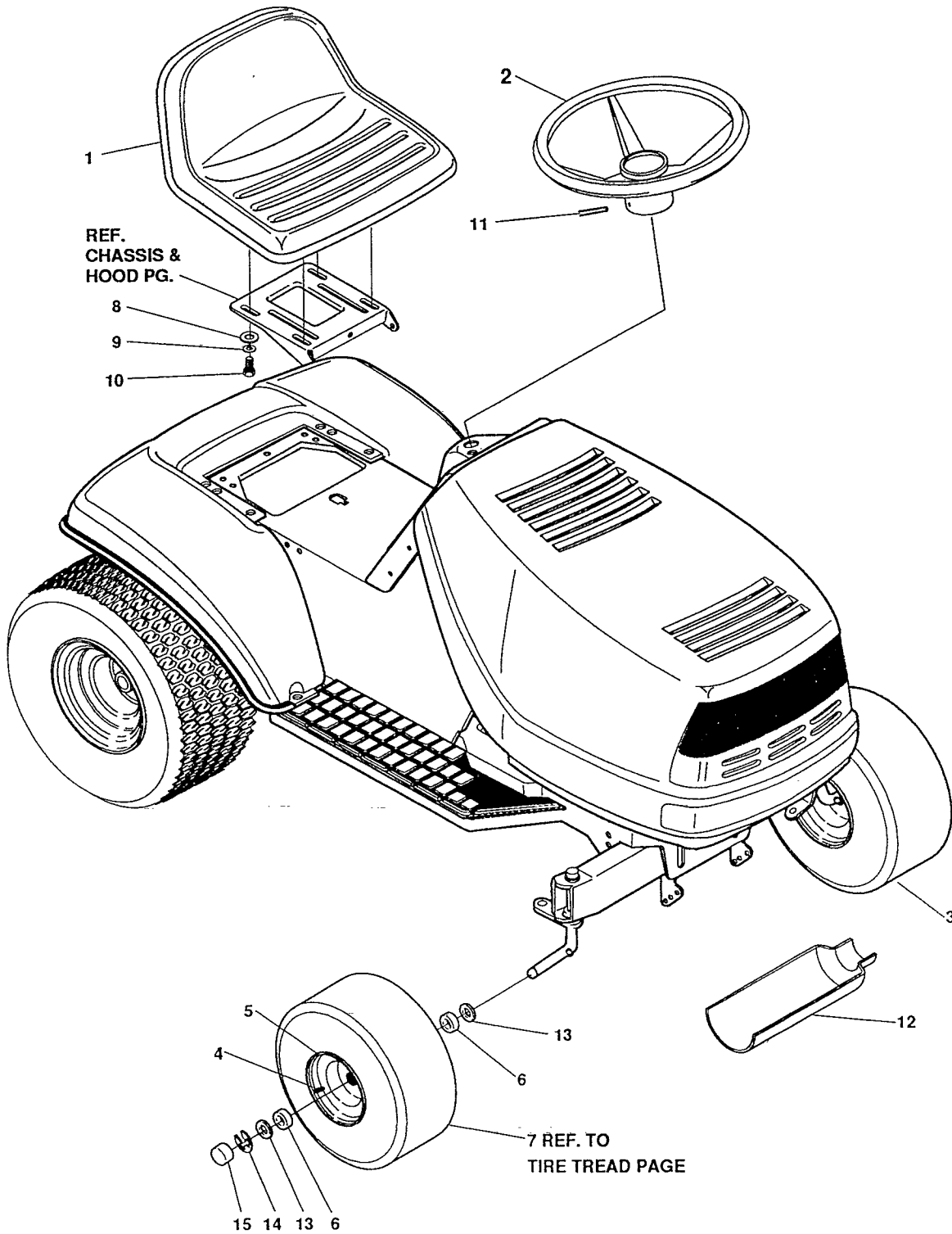

317694A

39" LAWN TRACTOR MODEL B3560-830

CUSTOMER ASSEMBLY VIEW

317690 PARTS BAG ASSY QTY1

key#	part#	decription	qty
1	57455	SEAT,550 MICH.	1
2	301251	WHEEL, STEERING, 13"	1
3	*	TIRE & RIM, PU 15X6.0X6 TURF	2
4	24167	VALVE STEM	1
5	39829	WHEEL W/BRG.	1
6	39979	BEARING,FL1.38OD+.753ID PM	2
7		REFER TO TIRE TREAD PAGE	
8	120393	WASHER, FLAT .344X .69X.065	4
9	120638	WASHER, HVSP TLK .328X.60X.09	4
10	122007	SCREW, 5/16-18X .75 HHC	4
11	456378	PIN, SPRING.250DIA X 2.00LG HVPL	1
12	54873	TROUGH, OIL DRAIN	1
13	642	WASHER, FLAT .755X1.31X.075	4
14	36625	RING, RETEX .57X.05TRU5133-75	2
15	40394	CAP, 1.500ID X 7/8LG HUB	2

TREAD PATTERNS

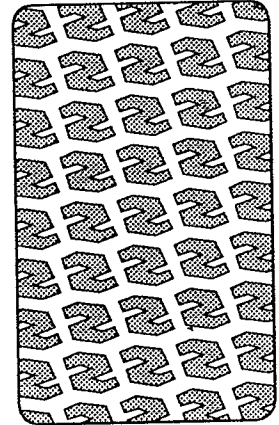
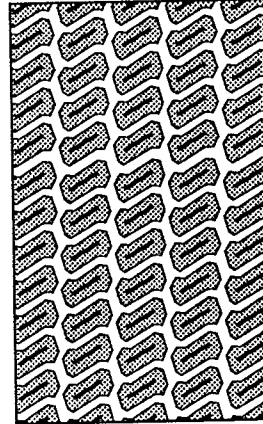
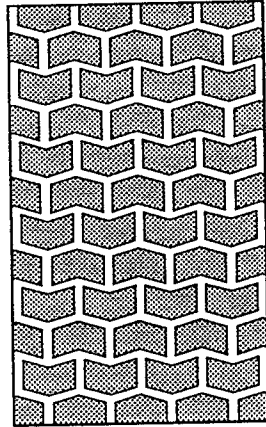
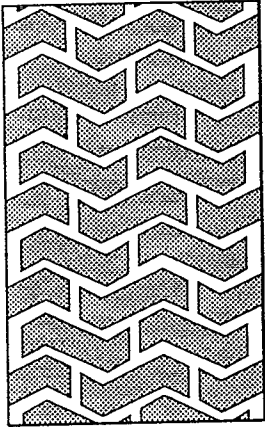

TIRE SIZE	"A"	"B"	"C"	"D"
11 X 4.00 - 5	42295			
13 X 5.00 - 6	41060			
15 X 6.00 - 6	301140	316702	39830	313952
16 X 6.50 - 8		41081		314539
18 X 6.50 - 8				
18 X 9.50 - 8		316701		313950
20 X 8.00 - 8	314584			
20 X 10.00 - 8	58276			313565
20 X 10.00 - 10		55893		
23 X 9.50 - 12	314370			
23 X 9.50 - 12		53655		

ACCESSORIES

Contact the dealer where your tractor was purchased for the available accessories. If you are unable to contact the dealer, write to the address on the front cover of this manual.

Rear Engine Rider

Model	Description
5708-16	Bagger - Fits 32" Side Discharge
5708-17	Bagger - Fits 36" Side Discharge
5709-02	Front Weight Box - holds 35 lbs.
5648-16	Lawn Sweeper w/dump Release

Lawn Tractor

Model	Description
5708-22	Bagger - Fits 30" Side Discharge
5708-13	Bagger - Fits 36", 38", 39" & 45" Side Discharge
5705-04	36" Two-Stage Snowblower - Fits 36", 38", 39", & 45" Side Discharge
5661-06	42" Snowblade - Fits 36", 38", 39", & 45"
5592-00	Tire Chains - 18" x 6.50"
5585-00	Tire Chains - 18" x 9.50" & 20" x 8"
5672-01	Wheel Weights - Front - 1 pr. w/mtg. hdw. - Fits 15" tires
5673-02	Wheel Weights - Rear - 1 pr. w/mtg. hdw. - Fits 18" & 20" tires
5709-03	Front Weights - Fits 30" & 32" Side Discharge
5648-16	Lawn Sweeper w/dump Release

Garden Tractor - Light Ground Engaging

Model	Description
5708-13	Bagger - Fits 36", 38", 39", & 45" Side Discharge
5705-04	36" Two - Stage Snowblower - Fits 36", 38", 39", & 45"
5661-06	42" Snowblade - Fits 36", 38", 39", & 45"
5672-01	Wheel Weights - Front 1 pr. w/mtg. hdw. - Fits 15" tires
5673-02	Wheel Weights - Rear - 1 pr. w/mtg. hdw. - Fits 18" & 20" tires
5648-16	Lawn Sweeper w/dump Release
5667-02	Sleeve Hitch - w/lift bar - Fits 45"
5668-01	Adaptor (sleeve hitch) for use w/23" tires
5706-00	Tire Chains - 20" x 10"
5671-00	Tire Chains - 23" x 9.50"
5672-02	Wheel Weights - Front - 1 pr. w/mtg. hdw. Fits 16" tires
5673-00	Wheel Weights - Rear - 1 pr. w/mtg. hdw. Fits 23" tires
5674-01*	10" One Bottom Moldboard Plow
5675-01*	Cultivator - 7 row - Adj. 6" - 42" width
5676-01*	Disc Harrow - 8" & 11" disc - Adj. width & disc angle
5677-02*	Tiller - 5 H.P. Self-Powered - 28" width

Four Wheel Steer

Model	Description
5708-14	Bagger - Fits 40" & 46" Side Discharge
5705-05	42" One-Stage Snowblower - Fits 40" & 46"
5661-07	48" Snowblade - Fits 40" & 46"
5709-04	Rear Weight Box for 40" & 46"
5648-16	Lawn Sweeper w/dump Release
5706-00	Tire Chains 20" x 10"
5671-00	Tire Chains 23" x 9.50"
5672-02	Wheel Weights - Front - 1 pr. w/mtg. hdw. Fits 16" tires
5673-00	Wheel Weights - Rear - 1 pr. w/mtg. hdw. Fits 23" tires
5672-01	Wheel Weights - Front - 1 pr. w/mtg. hdw. Fits 15" tires
5673-02	Wheel Weights - Rear - 1 pr. w/mtg. hdw. Fits 18" & 20" tires

Four Wheel Steer Garden Tractor

Model	Description
5667-04	Sleeve Hitch - w/lift bar Fits 46"
5674-01*	10" One Bottom Moldboard Plow
5675-01*	Cultivator - 7 row - Adj. 6" - 42" width
5676-01*	Disc Harrow 8" & 11" Disc. Adj. width & disc angle
5677-02*	Tiller 5 H.P. Self-Powered - 28" width
5648-16	Lawn Sweeper w/dump Release

*Requires a sleeve hitch