

Ausgabe Issue 2008-31		Bild Nr Picture No C067B		XM 130 XM 140 HD- XM 160 HD MONTAGETEILEN		XM 130 XM 140 HD- XM 160 HD ASSEMBLY PARTS		Seite Page 26	
Pos. Fig.	Anzahl/Quantity				Artikel Nr. Part No	Bezeichnung	Description	Satz Kit	Anmerkung Notes
	2781 -88	2782 -88	2783 -88	2782 -38 2783 -38					
1	1	1	1	1	9595-0262-00	Spannstift	Locating pin		
2A	1	1	1	1	9699-0103-02	Scheibe.....	Flat washer.....		0.5 mm
2B	1	1	1	1	9699-0114-02	Scheibe.....	Flat washer.....		1.0 mm
3	2	2	2	2	1134-4185-01	Flanschscheibe	Flange washer		
5	4	4	4	4	9699-0056-02	Scheibe.....	Flat washer.....		
7	1	1	1	1	1134-4627-01	Anhängerstrebe	Tow bar		
8	2	2	2	2	9959-0820-16	Schraube	Screw.....		
9	4	4	4	4	9997-0820-16	Schraube	Screw.....		
10	1	1	1	1	1134-6125-01	Zündschlüssel	Ignition key		
11	1	1	1	1	1134-5245-01	Batterieriemen	Battery strap		
12	1	1	1	1	1134-6113-01	Batterieschrauben.....	Battery screws		
13	2	2	2	2	9898-1035-16	Schraube	Screw.....		
14	2	2	2	2	9739-1031-22	Mutter	Nut		
X	21	1	1	1	8211-0081-80	Bedienungsanleitung	Owner's manual		
X	21	1	1	1	8211-0082-80	Bedienungsanleitung	Owner's manual		
X	21	1	1	1	8211-0084-80	Bedienungsanleitung	Owner's manual		Canada
X	21	1	1	1	8211-0781-80	Sicherheitsvorschrift	Safety regulations		

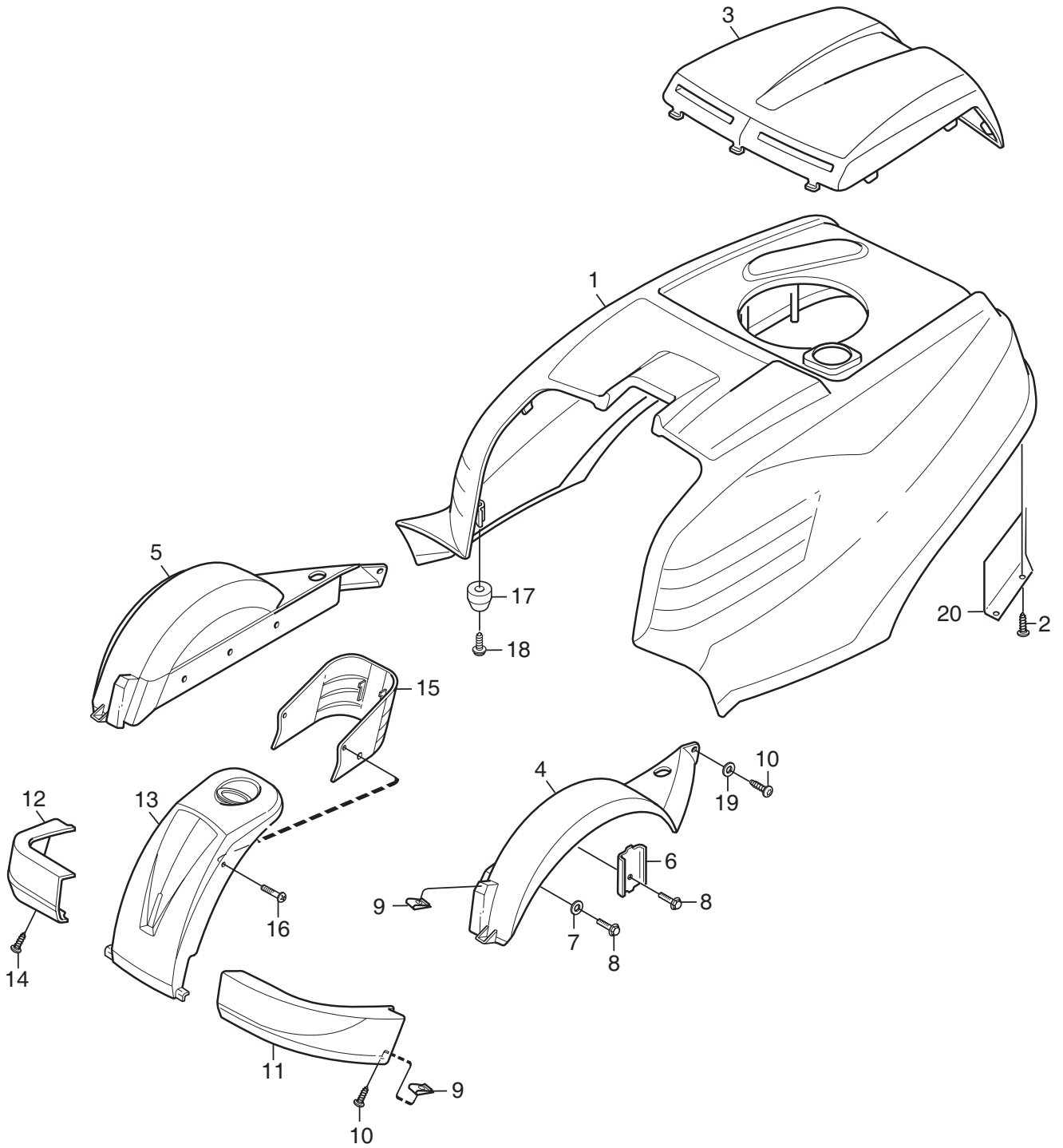

Ausgabe Issue 2008-31		Bild Nr Picture No C068B		XM 130 XM 140 HD- XM 160 HD KAROSSERIE		XM 130 XM 140 HD- XM 160 HD BODY WORK		Seite Page 28	
Pos. Fig.	Anzahl/Quantity			Artikel Nr. Part No	Bezeichnung	Description	Satz Kit	Anmerkung Notes	
	2781 -88	2782 -38 -88	2783 -38 -88						
1	1	1	1	1134-5392-01	Motorhaube- rot.....	Engine hood- red.....			
2	7	7	7	9838-9530-12	Schraube	Screw			
3	1	1	1	1134-5393-01	Motordeckel- grau	Engine cover- grey			
4	1	1	1	1134-5307-05	Kotflügel- L	Mud guard- LH			
5	1	1	1	1134-5307-06	Kotflügel- R.....	Mud guard- RH			
6	2	2	2	1134-0225-00	Stützblech.....	Support plate			
7	4	4	4	9699-0056-02	Scheibe.....	Flat washer.....			
8	6	6	6	9945-0816-16	Schraube	Screw			
9	4	4	4	1134-4176-01	Klemme	Clips			
10	4	4	4	9893-0616-16	Schraube	Screw.....			
11	1	1	1	1134-5367-01	Stoßfänger- vorder, L.....	Bumper- front, LH			
12	1	1	1	1134-5367-02	Stoßfänger- vorder, R	Bumper- front, RH.....			
13	1	1	1	1134-5362-01	Vorderteil- untere.....	Front- lower			
14	6	6	6	9893-0616-16	Schraube	Screw			
15	1	1	1	1134-5361-01	Vorderdeckel	Front cover.....			
16	2	2	2	9840-8019-16	Schraube	Screw.....			
17	2	2	2	1134-4790-02	Haubenführung.....	Hood guide			
18	2	2	2	9838-9530-12	Schraube	Screw			
19	2	2	2	9699-0060-02	Scheibe.....	Flat washer.....			
20			1	1134-6199-01	Deflektor	Deflector			

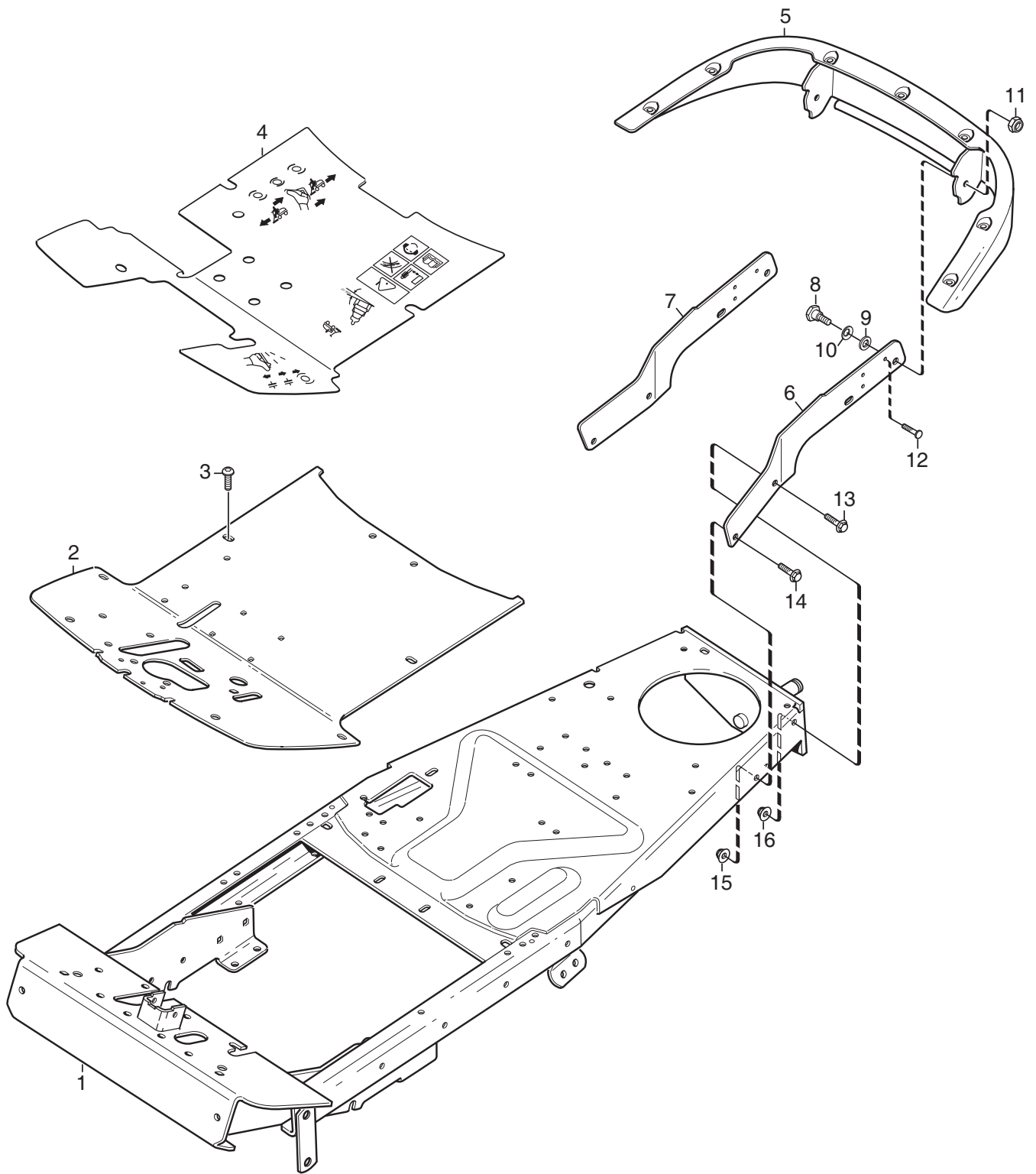

C069A

Ausgabe Issue 2008-31		Bild Nr Picture No C069A		XM 130 XM 140 HD- XM 160 HD RAHMEN		XM 130 XM 140 HD- XM 160 HD FRAME		Seite Page 30	
Pos. Fig.	Anzahl/Quantity			Artikel Nr. Part No	Bezeichnung	Description	Satz Kit	Anmerkung Notes	
	2781 -88	2782 -38 -88	2783 -38 -88						
1	1	1	1	1134-5546-02	Rahmen	Frame			
2	1	1	1	1134-5293-02	Bodenblech	Floor plate			
3	2	2	2	9893-0616-16	Schraube	Screw			
4	1			1134-5338-02	Bodenblechmatte	Floor mat			
4		1	1	1134-5339-02	Bodenblechmatte	Floor mat			
5	1	1	1	1134-5453-02	Stoßfänger- hintere	Bumper- rear			
6	1	1	1	1134-5334-01	Halterung- L	Attachment- LH			
7	1	1	1	1134-5334-02	Halterung- R	Attachment- RH			
8	2	2	2	1134-0240-00	Ansatzbolzen	Shoulder screw			
9	2	2	2	1134-4242-01	Distanzscheibe	Spacer washer			
10	2	2	2	9694-0001-00	Scheibe	Washer			
11	2	2	2	9747-0831-02	Mutter	Lock nut			
12	2	2	2	9943-0516-16	Schraube	Screw			
13	2	2	2	9959-0820-16	Schraube	Screw			
14	2	2	2	9959-0825-16	Schraube	Screw			
15	1	1	1	9739-0831-22	Mutter	Nut			
16	3	3	3	9739-0831-22	Mutter	Nut			

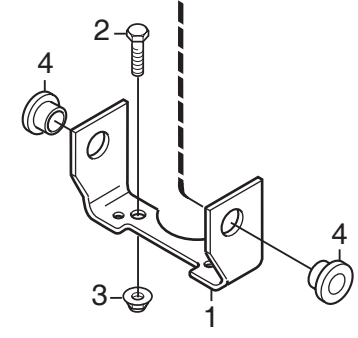
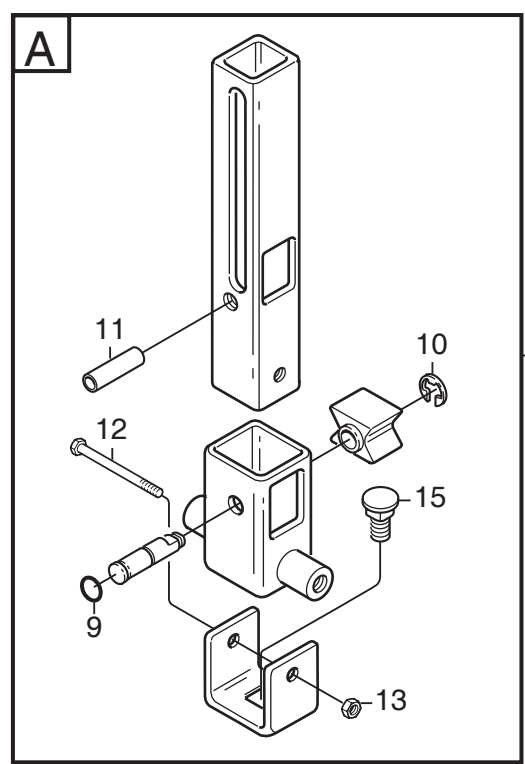
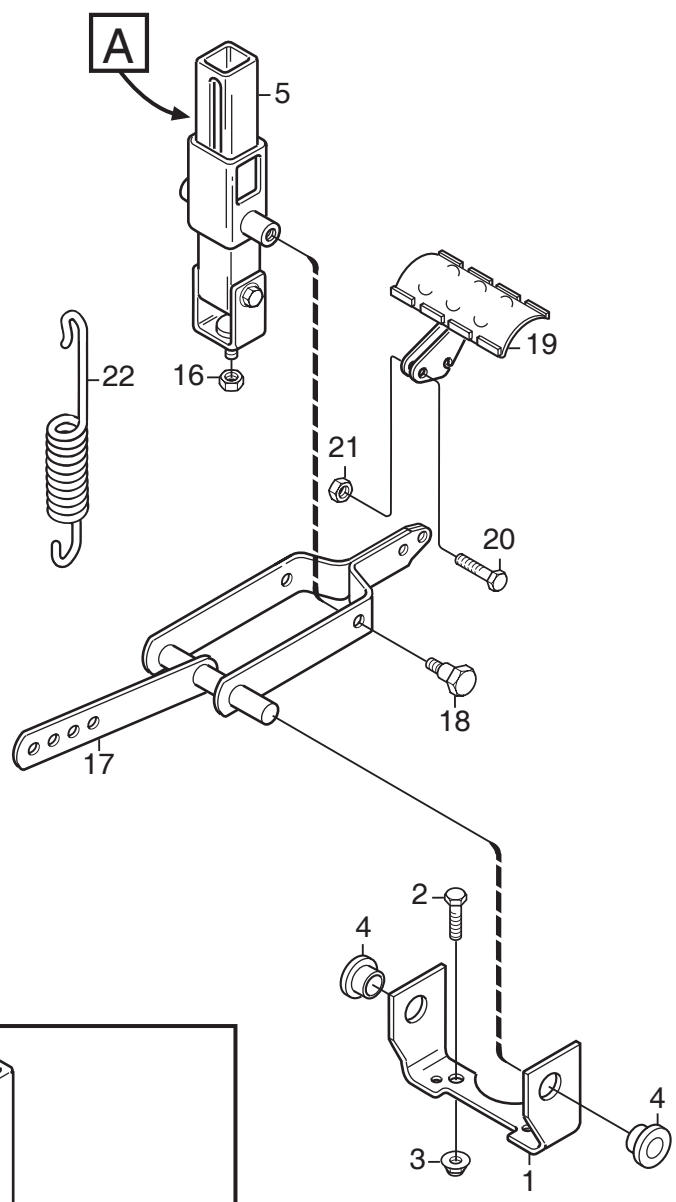

Ausgabe Issue 2008-31		Bild Nr Picture No C070		XM 130 XM 140 HD- XM 160 HD PEDALHEBER		XM 130 XM 140 HD- XM 160 HD PEDAL LIFT		Seite Page 32	
Pos. Fig.	Anzahl/Quantity			Artikel Nr. Part No	Bezeichnung	Description	Satz Kit	Anmerkung Notes	
	2781 -88	2782 -38 -88	2783 -38 -88						
1	1	1	1	1134-4117-01	Halterung	Bracket		Pos 9 - 15 incl.	
2	2	2	2	9959-1025-16	Schraube	Screw			
3	2	2	2	9739-1031-22	Mutter	Nut			
4	2	2	2	1134-2684-01	Lager	Bearing			
5	1	1	1	1134-4945-01	Hebesperre Kpl	Lift catch assy			
9	1	1	1	9404-0027-01	• O-ring	• O-ring			
10	1	1	1	9650-0039-04	• Schließring	• Lock ring			
11	1	1	1	9595-0276-01	• Spannstift	• Locating pin			
12	1	1	1	9997-0640-12	• Schraube	• Screw			
13	1	1	1	9747-0631-02	• Mutter	• Lock nut			
15	1	1	1	9897-0820-16	• Schraube	• Screw			
16	1	1	1	9747-0831-02	Mutter	Lock nut			
17	1	1	1	1134-4860-01	Hebegabel	Lift fork			
18	2	2	2	1134-0240-00	Ansatzbolzen	Shoulder screw			
19	1	1	1	1134-4938-01	Hebepedal	Lift pedal			
20	2	2	2	9997-0625-16	Schraube	Screw			
21	2	2	2	9739-0631-22	Mutter	Nut			
22	1	1	1	4231-0013-00	Feder	Spring			

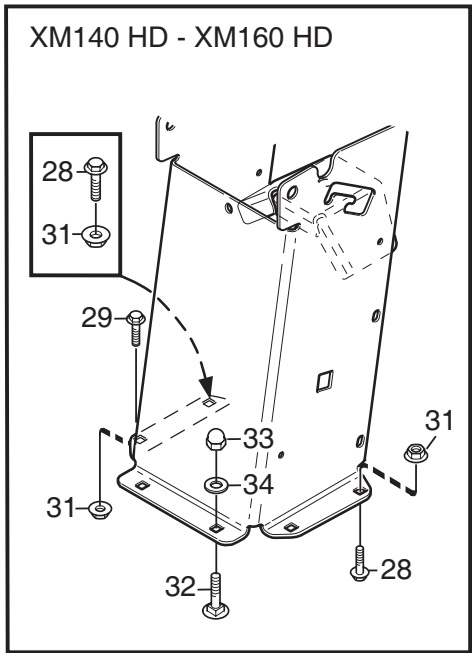
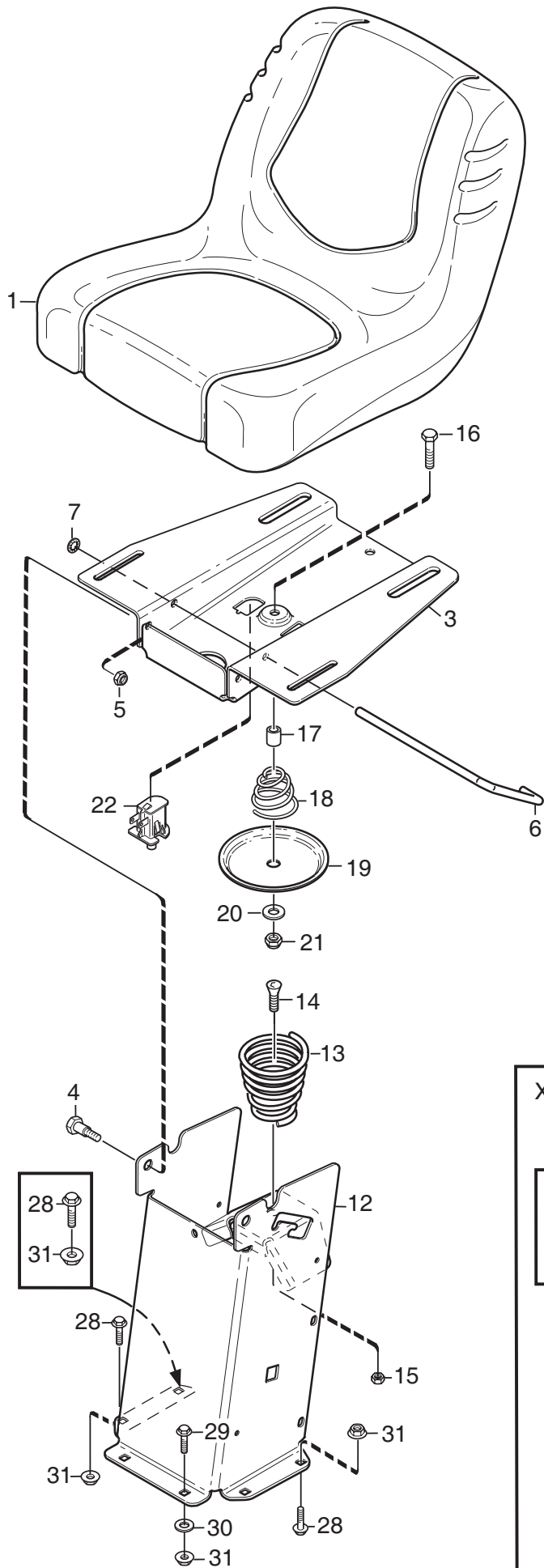

Ausgabe Issue 2008-31		Bild Nr Picture No C071B		XM 130 XM 140 HD- XM 160 HD SITZ		XM 130 XM 140 HD- XM 160 HD SEAT		Seite Page 34	
Pos. Fig.	Anzahl/Quantity			Artikel Nr. Part No	Bezeichnung	Description	Satz Kit	Anmerkung Notes	
	2781 -88	2782 -38 -88	2783 -38 -88						
1	1	1	1	1134-5534-01	Sitz	Seat			
3	1	1	1	1134-5301-01	Sitzplatte	Seat plate			
4	2	2	2	1134-0240-00	Ansatzbolzen	Shoulder screw			
5	2	2	2	9747-0831-02	Mutter	Lock nut			
6	1	1	1	1134-5454-01	Sperre	Catch			
7	1	1	1	9675-0012-02	Verriegelungsscheibe	Locking washer			
12	1	1	1	1134-5296-05	Sitzkonsole- schw.	Seat bracket- black			
13	1	1	1	1134-4256-01	Sitzfeder	Seat spring			
14	1	1	1	9924-1235-19	Schraube	Screw			
15	1	1	1	9747-1231-02	Mutter	Lock nut			
16	1	1	1	9997-0840-16	Schraube	Screw			
17	1	1	1	1134-1565-06	Distanz	Spacer			
18	1	1	1	1134-5302-01	Feder	Spring			
19	1	1	1	1134-5299-01	Druckplatte	Push plate			
20	1	1	1	9699-0090-02	Scheibe	Flat washer			
21	1	1	1	9747-0831-02	Mutter	Lock nut			
22	1	1	1	1134-3156-02	Schalter (grau)	Switch (grey)			
28	4	3	3	9959-0820-16	Schraube	Screw		L = 20 mm	
29	2	1	1	9959-0825-16	Schraube	Screw		L = 25 mm	
30	2			9699-0056-02	Scheibe	Flat washer			
31	6	4	4	9739-0831-22	Mutter	Nut			
32		2	2	9897-0820-16	Schraube	Screw			
33		2	2	9757-0821-02	Mutter	Cap nut			
34		2	2	9699-0090-02	Scheibe	Flat washer			

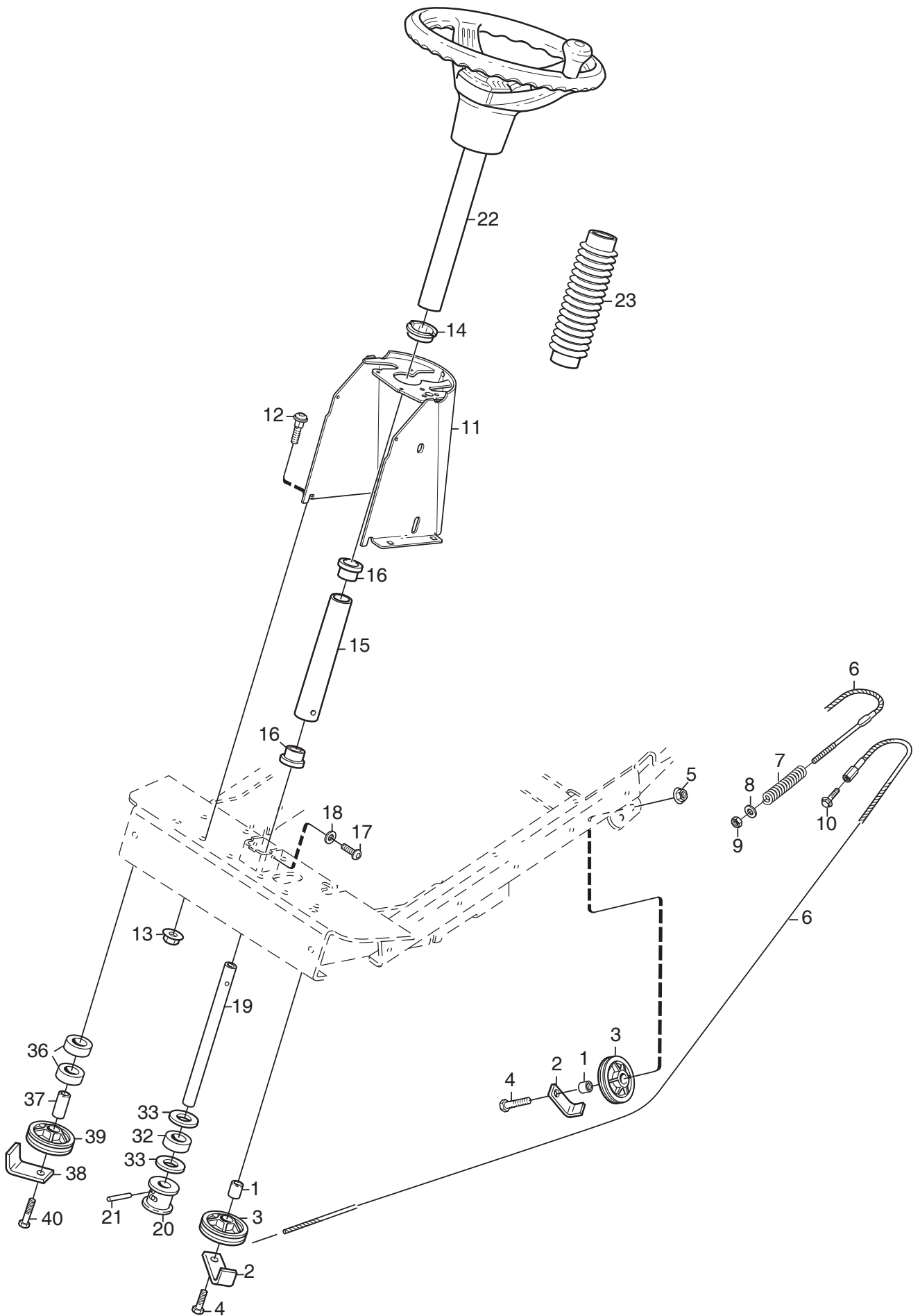

C072

Ausgabe Issue 2008-31		Bild Nr Picture No C072		XM 130 XM 140 HD- XM 160 HD LENKUNG		XM 130 XM 140 HD- XM 160 HD STEERING		Seite Page 36	
Pos. Fig.	Anzahl/Quantity			Artikel Nr. Part No	Bezeichnung	Description	Satz Kit	Anmerkung Notes	
	2781 -88	2782 -38 -88	2783 -38 -88						
X	1	3	3	3	1134-0041-01	Hülse	Bushing		
X	2	3	3	3	1134-0046-00	Drahthalter	Wire clamp		
X	3	3	3	3	1134-0072-02	Seilrolle	Steering pulley		
	4	3	3	3	9997-1040-16	Schraube	Screw		
	5	2	2	2	9739-1031-22	Mutter	Nut		
	6	1	1	1	1134-2032-04	Lenkdrahtseil	Steering cable		
	7	1	1	1	1134-1310-01	Druckfeder	Compression spring		
	8	1	1	1	9699-0056-02	Scheibe	Flat washer		
	9	1	1	1	9747-0831-02	Mutter	Lock nut		
	10	1	1	1	9959-0820-16	Schraube	Screw		
	11	1	1	1	1134-5349-05	Lenkkonsole- grau	Steering console- grey		
	12	4	4	4	9897-0820-16	Schraube	Screw		
	13	4	4	4	9739-0831-22	Mutter	Nut		
	14	1	1	1	1134-4483-01	Buchse	Bushing		
	15	1	1	1	1134-1305-05	Lenkrohr- untere	Steering column- lower		
	16	2	2	2	1134-1901-01	Lager	Bearing		
	17	2	2	2	9893-0616-16	Schraube	Screw		
	18	2	2	2	9699-0060-02	Scheibe	Flat washer		
	19	1	1	1	1134-5495-01	Lenkstange	Steering rod		
	20	1	1	1	1134-1933-01	Lenkrolle	Steering pulley		
	21	1	1	1	9595-0262-00	Spannstift	Locating pin		
	22	1	1	1	1134-5533-01	Lenkrad	Steering wheel		
	23	1	1	1	1134-5545-01	Lenkstangenschutz	Steering tube muff		
	32	1	1	1	1134-3047-01	Distanz	Spacer		
	33	2	2	2	9699-0104-02	Scheibe	Washer		
	36	2	2	2	1134-3047-01	Distanz	Spacer		
	37	1	1	1	1134-0041-05	Hülse	Bushing		
X	38	1	1	1	1134-0046-00	Drahthalter	Wire clamp		
X	39	1	1	1	1134-0072-02	Seilrolle	Steering pulley		
	40	1	1	1	9997-1060-12	Schraube	Screw		

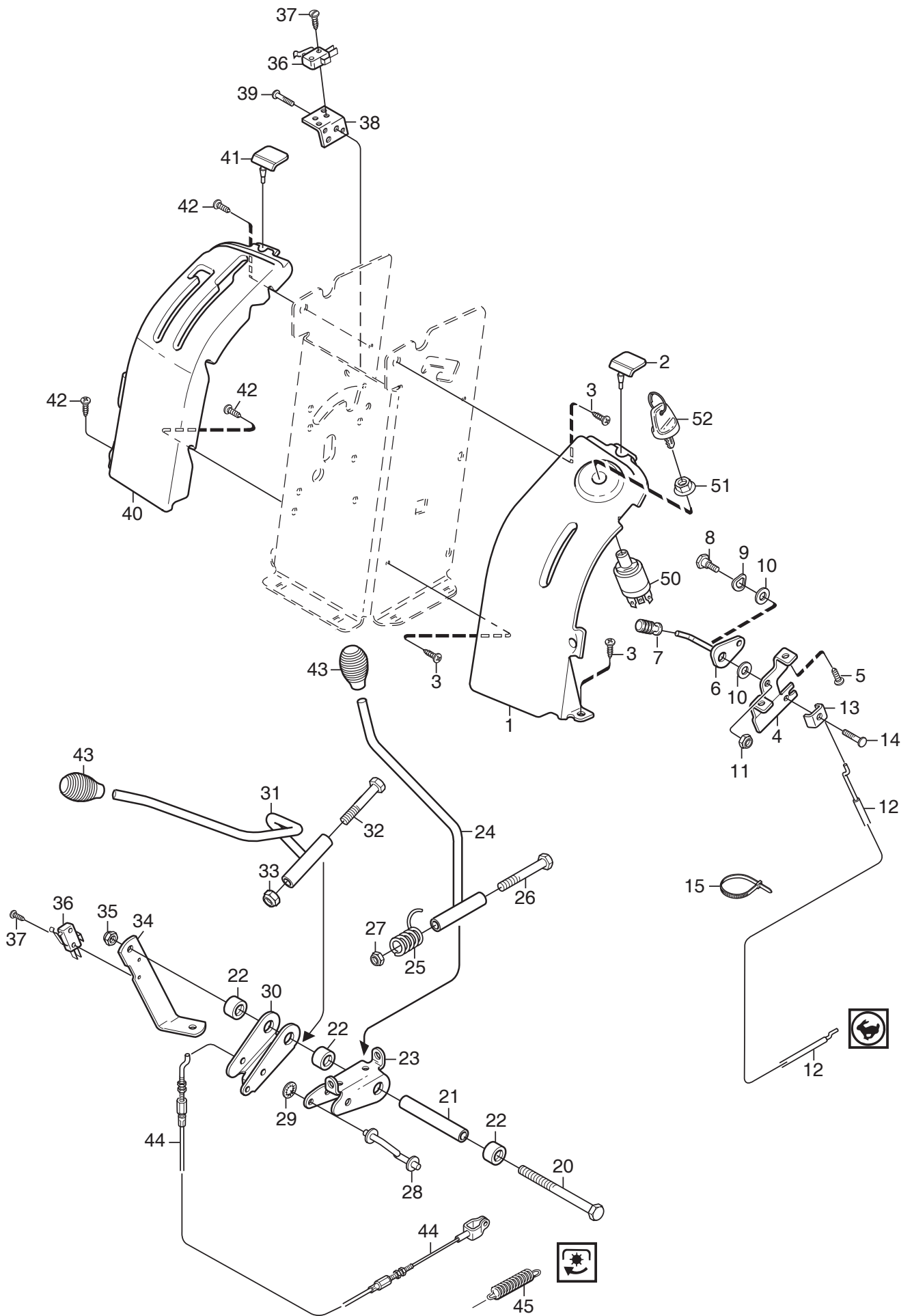

C073

Ausgabe Issue 2008-31		Bild Nr Picture No C073		XM 130 HANDREGULIERUNG		XM 130 HAND CONTROLS		Seite Page 38	
Pos. Fig.	Anzahl/Quantity				Artikel Nr. Part No	Bezeichnung	Description	Satz Kit	Anmerkung Notes
	2781 -88								
1	1				1134-5286-03	Regulierpanel- L.....	Control panel- LH.....		
2	2				1134-5531-01	Dämpfer.....	Absorber.....		
3	3				9893-0616-16	Schraube.....	Screw.....		
4	1				1134-5357-01	Halterung.....	Bracket.....		
5	2				9838-9516-12	Schraube.....	Screw.....		
6	1				1134-4077-01	Gasregulierung.....	Throttle control.....		
7	1				1134-5563-01	Knopf.....	Knob.....		
8	1				1134-0240-00	Ansatzbolzen.....	Shoulder screw.....		
9	1				9694-0001-00	Scheibe.....	Washer.....		
10	2				1134-4242-01	Distanzscheibe.....	Spacer washer.....		
11	1				9747-0831-02	Mutter.....	Lock nut.....		
12	1				1134-1597-13	Gasdraht.....	Throttle cable.....		
13	1				9500-9991-00	Drahtklemme.....	Cable clamp.....		
14	1				9943-0516-16	Schraube.....	Screw.....		
15	1				9579-0003-00	Kabelhalter.....	Cable holder.....		
20	1				9997-0812-02	Schraube.....	Screw.....		
21	1				1134-5274-02	Distanz.....	Spacer.....		
22	3				1134-3047-01	Distanz.....	Spacer.....		
23	1				1134-5271-01	Regulierhalterung.....	Control bracket.....		
24	1				1134-5275-01	Schalthebel.....	Gear shift lever.....		
25	1				1134-5535-01	Feder.....	Spring.....		
26	1				9997-0890-12	Schraube.....	Screw.....		
27	1				9747-0831-02	Mutter.....	Lock nut.....		
28	1				1134-5268-01	Schaltstange.....	Shifter rod.....		
29	1				9675-0009-02	Verriegelungsscheibe.....	Starlock.....		
30	1				1134-5271-01	Regulierhalterung.....	Control bracket.....		
31	1				1134-5276-01	Regulierhebel.....	Control lever.....		
32	1				9997-0890-12	Schraube.....	Screw.....		
33	1				9747-0831-02	Mutter.....	Lock nut.....		
34	1				1134-5356-01	Strebe.....	Strut.....		
35	1				9747-0831-02	Mutter.....	Lock nut.....		
36	2				9400-0312-01	Schalter.....	Micro switch.....		
37	4				9840-7716-16	Schraube.....	Screw.....		
38	1				1134-5358-01	Schalhalterung.....	Switch bracket.....		
39	2				9943-0516-16	Schraube.....	Screw.....		
40	1				1134-5285-05	Regulierpanel- R.....	Control panel- RH.....		
41	2				1134-5531-01	Dämpfer.....	Absorber.....		
42	4				9893-0616-16	Schraube.....	Screw.....		
43	2				1134-5564-01	Regulierknopf.....	Control knob.....		
44	1				1134-3573-06	Nebenantriebsdraht.....	PTO cable.....		
45	1				1134-1242-02	Feder.....	Spring.....		
50	1				1134-4093-01	Zündschloß.....	Ignition switch.....		
51	1				1134-4749-01	Mutter.....	Nut.....		
52	1				1134-4734-01	Zündschlüssel.....	Ignition key.....		

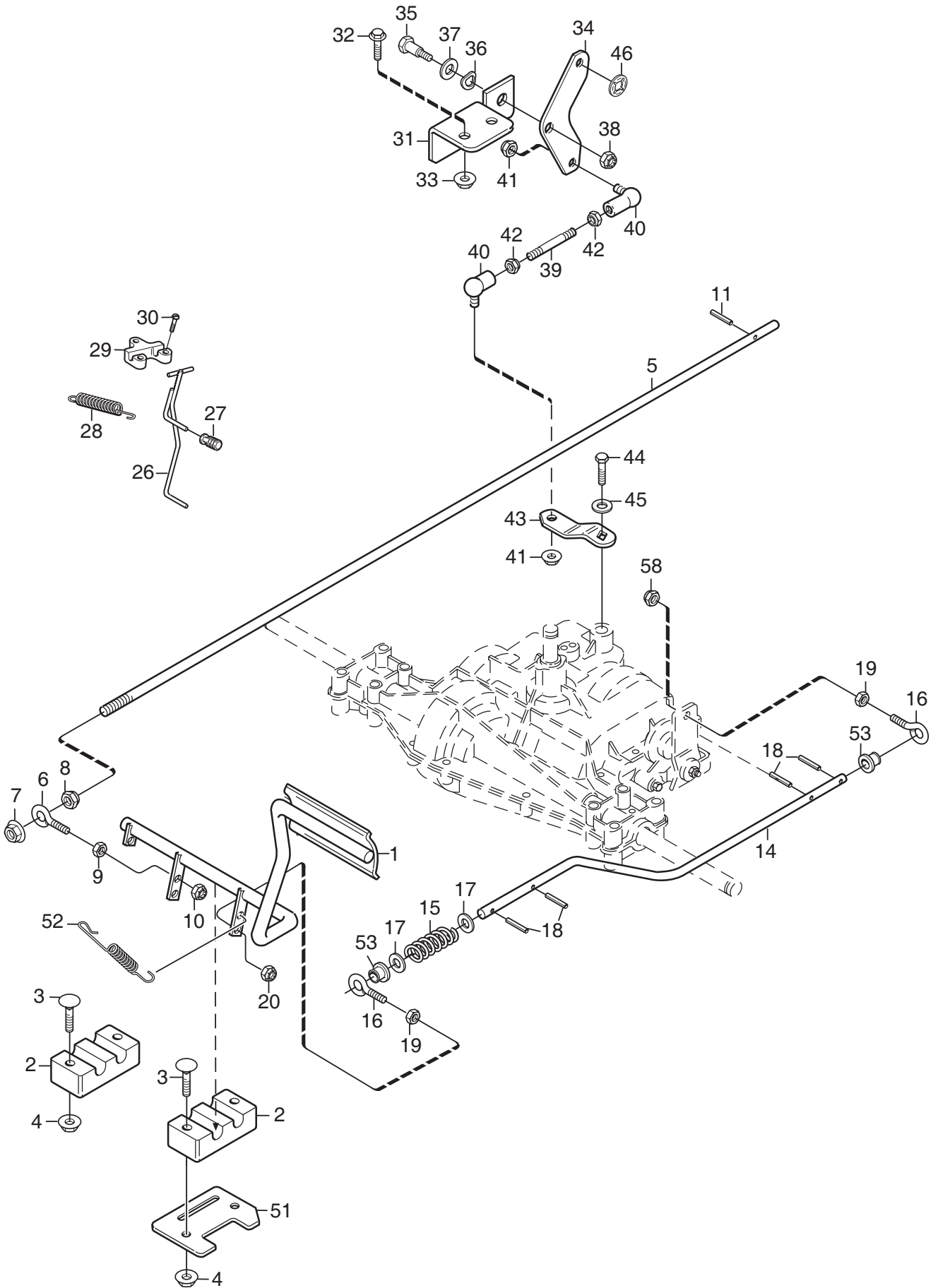

C075B

Ausgabe Issue 2008-31		Bild Nr Picture No C075B		XM 130 FUßREGULIERUNG		XM 130 FOOT CONTROLS		Seite Page 42	
Pos. Fig.	Anzahl/Quantity				Artikel Nr. Part No	Bezeichnung	Description	Satz Kit	Anmerkung Notes
	2781 -88								
1	1				1134-4802-01	Pedal	Pedal		
2	2				1134-4624-01	Lager	Bearing		
3	4				9897-0640-12	Schraube	Screw		
4	4				9739-0631-22	Mutter	Nut		
5	1				1134-4795-01	Kupplungsstange	Clutch rod		
6	1				1134-2138-01	Schrauböse	Eye bolt		
7	1				9739-1031-22	Mutter	Nut		
8	1				9731-1031-22	Mutter	Nut		
9	1				9739-0831-22	Mutter	Nut		
10	1				9747-0831-02	Mutter	Lock nut		
11	1				9595-0208-00	Spannstift	Locating pin		
14	1				1134-4777-01	Bremsstange	Brake rod		
15	1				1134-4617-01	Feder	Spring		
16	2				1134-2138-01	Schrauböse	Eye bolt		
17	2				9699-0035-02	Scheibe	Flat washer		
18	4				9595-0208-00	Spannstift	Locating pin		
19	2				9739-0831-22	Mutter	Nut		
20	1				9747-0831-02	Mutter	Lock nut		
26	1				1134-5353-01	Bremsstange	Brake rod		
27	1				1134-5566-01	Knopf	Knob		
28	1				1131-1497-01	Feder	Spring		
29	1				1134-4002-01	Halterung	Brake rod attachment		
30	3				9838-9516-12	Schraube	Screw		
31	1				1134-4714-01	Winkelhalterung	Angle bracket		
32	2				9959-0820-16	Schraube	Screw		
33	2				9739-0831-22	Mutter	Nut		
34	1				1134-4715-01	Dreieckenblech	Triangular plate		
35	1				1134-0240-00	Ansatzbolzen	Shoulder screw		
36	1				9694-0001-00	Scheibe	Washer		
37	1				9699-0036-02	Scheibe	Flat washer		
38	1				9747-0831-02	Mutter	Lock nut		
39	1				1134-4717-02	Gewindestange	Threaded rod		
40	2				9570-0004-00	Winkelgelenk	Elbow link		
41	2				9747-0631-02	Mutter	Lock nut		
42	2				9739-0631-22	Mutter	Nut		
43	1				1134-5279-01	Schaltarm	Shift lever		
43	1				1134-6351-01	Schaltarm	Shift lever		
44	1				9987-5016-16	Schraube	Screw		
45	1				9699-0060-02	Scheibe	Flat washer		
46	1				9675-0009-02	Verriegelungsscheibe	Starlock		
51	1				1134-4793-01	Halteblech	Stop plate		
52	1				4231-0013-00	Feder	Spring		
53	2				1134-4779-01	Plastikbuchse	Plastic bushing		
58	1				9747-0831-02	Mutter	Lock nut		

Dana 4360-197
Dana 6800-7

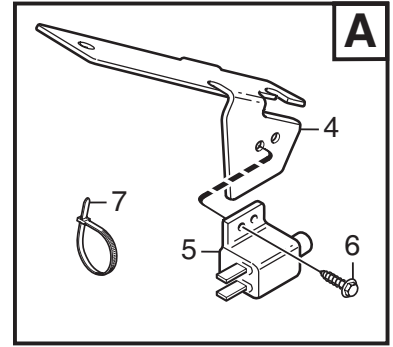
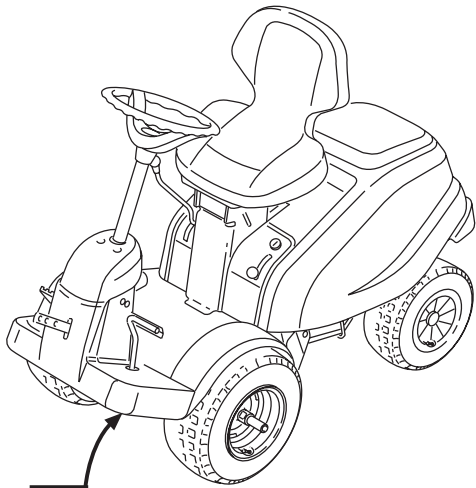

A

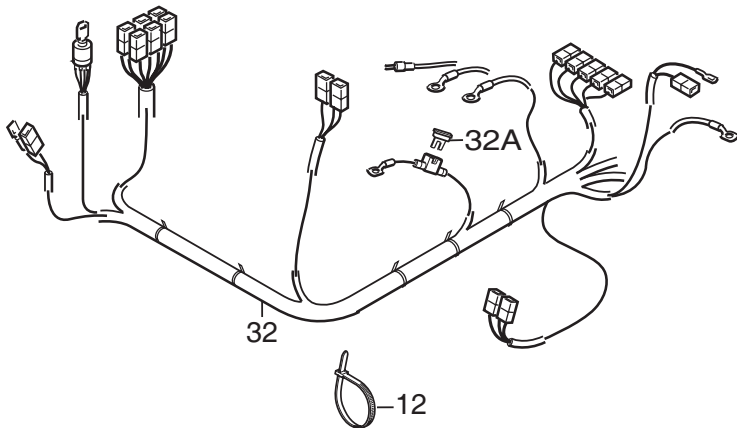
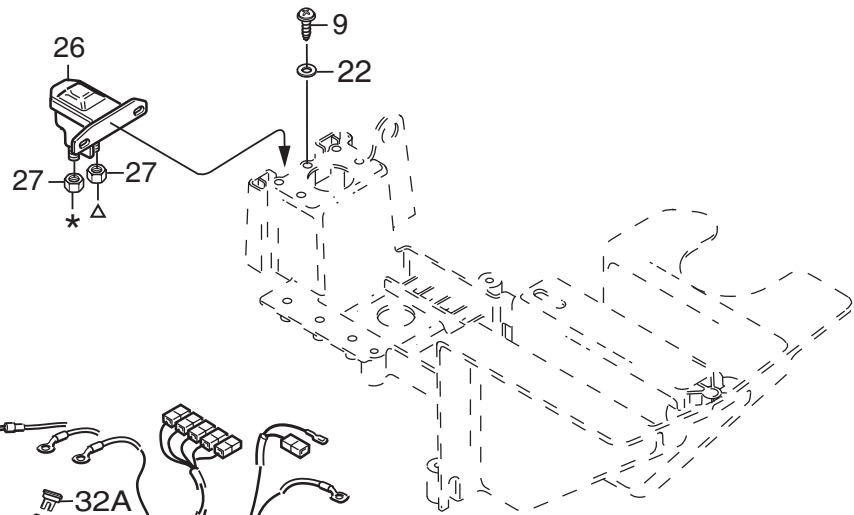
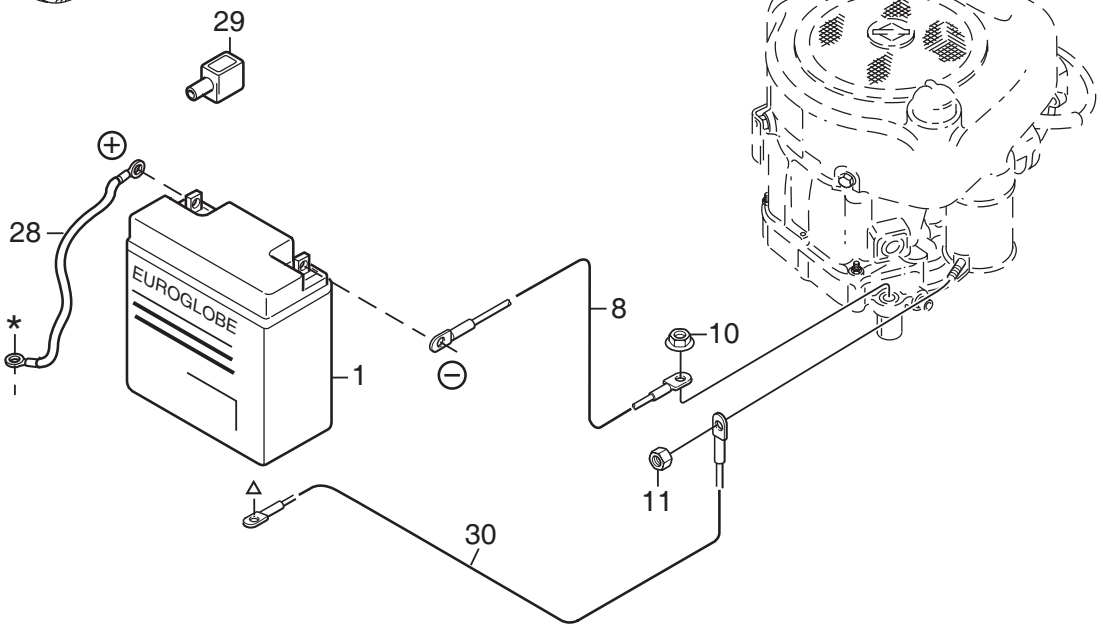

C077B

Ausgabe Issue 2008-31		Bild Nr Picture No C077B		XM 130 XM 140 HD- XM 160 HD EL. AUSSTATTUNG	XM 130 XM 140 HD- XM 160 HD ELECTRIC EQUIPMENT	Seite Page 46		
Pos. Fig.	Anzahl/Quantity			Artikel Nr. Part No	Bezeichnung	Description	Satz Kit	Anmerkung Notes
	2781 -88	2782 -38 -88	2783 -38 -88					
1	1	1	1	1134-4804-01	Batterie	Battery		
4		1	1	1134-4610-01	Schalthalterung	Switch bracket		
5		1	1	1134-3399-02	Schalter	Switch		
6		2	2	9852-8013-16	Schraube	Screw		
7		3	3	9579-0003-00	Kabelhalter.....	Cable holder		
8	1	1	1	1134-2042-02	Kabel- schwarz	Cable- black.....		L = 350 mm
9	1	1	1	9838-9516-12	Schraube	Screw		
10	1	1	1	9747-0831-02	Mutter	Lock nut		
11	1	1	1	9795-3531-02	Mutter	Nut		1/4" UNC
12	3	3	3	9579-0003-00	Kabelhalter.....	Cable holder		
22	1	1	1	9699-0060-02	Scheibe.....	Flat washer.....		
26	1	1	1	1134-3901-01	Magnetschalter	Solenoid		
27	2	2	2	9794-5131-02	Mutter	Nut		
28	1	1	1	1134-0234-02	Batteriekabel (+)	Battery cable (+).....		L = 395 mm
29	1	1	1	1134-2310-01	Schutzkappe	Guard cap		
30	1	1	1	1134-4702-02	Kabel- rot	Cable- red.....		L = 480 mm
32		1	1	1134-5767-01	Kabelbündel.....	Harness.....		
X 32	1			1134-7218-01	Kabelbündel.....	Harness.....		
32A	1	1	1	1134-3496-06	• Sicherung	• Fuse		20A

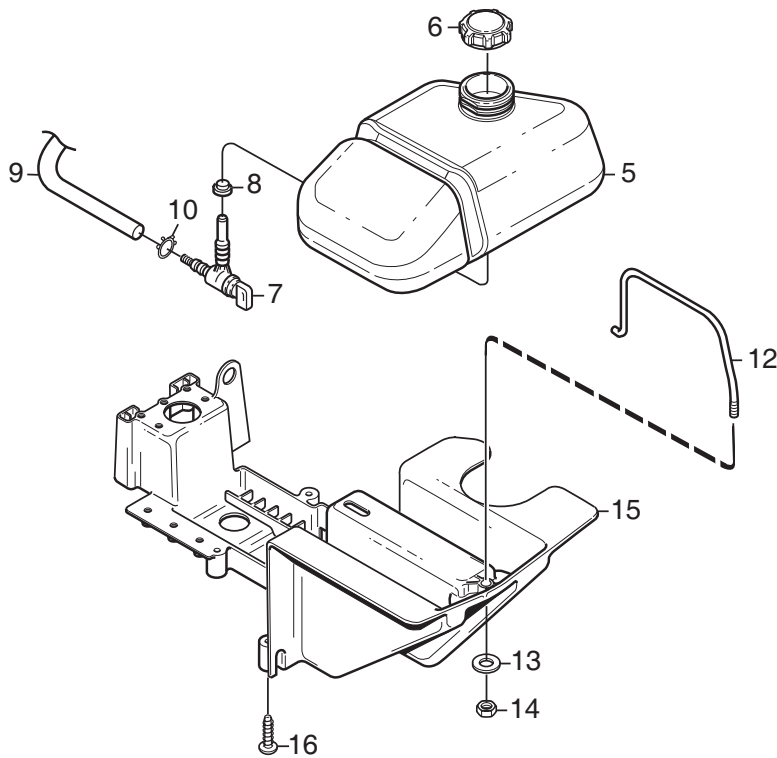
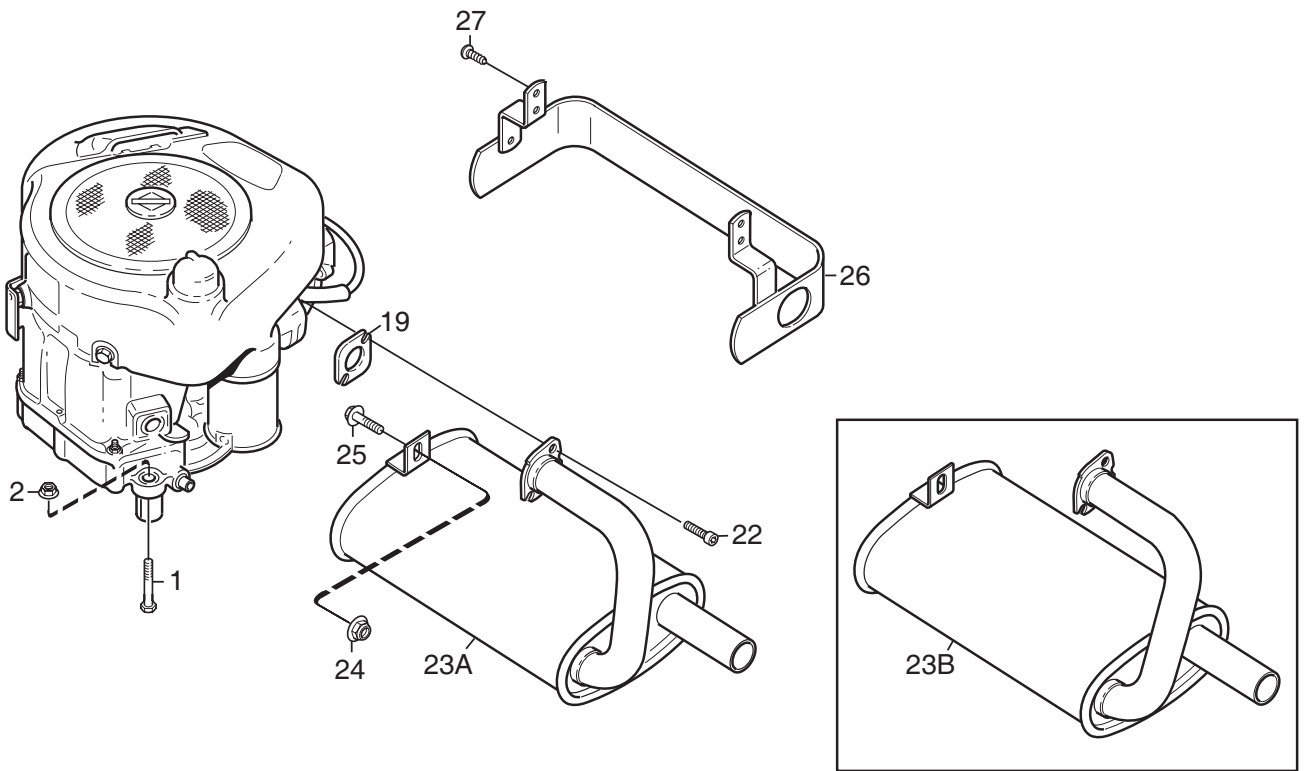

C078A

Ausgabe Issue 2008-31		Bild Nr Picture No C078A		XM 130 XM 140 HD- XM 160 HD MOTOR		XM 130 XM 140 HD- XM 160 HD ENGINE		Seite Page 48	
Pos. Fig.	Anzahl/Quantity			Artikel Nr. Part No	Bezeichnung	Description	Satz Kit	Anmerkung Notes	
	2781 -88	2782 -38 -88	2783 -38 -88						
1	4	4	4	9997-0840-16	Schraube	Screw		L = 460 mm	
2	4	4	4	9747-0831-02	Mutter	Lock nut			
5	1	1	1	1134-5266-01	Benzintank	Fuel tank			
6	1	1	1	1134-5532-01	Tankdeckel	Fuel tank cap			
7	1	1	1	1134-3224-01	Benzinhahn	Fuel shut-off valve			
8	1	1	1	1134-3225-01	Gummibuchse	Grommet			
9	1	1	1	1134-2975-05	Benzinschlauch	Fuel hose			
10	2	2	2	9578-0023-02	Schlauchklemme	Hose clamp			
12	1	1	1	1134-4808-01	Tankbügel	Tank clamp			
13	1	1	1	9699-0060-02	Scheibe	Flat washer			
14	1	1	1	9747-0631-02	Mutter	Lock nut			
15	1	1	1	1134-4807-02	Tank/Batterieregal	Tank/battery shelf			
16	4	4	4	9829-8830-12	Schraube	Screw			
19	1	1	1	1134-0433-00	Schalldämpferdichtung	Muffler gasket			
22	2	2	2	1134-4930-01	Schraube	Screw			
23A	1	1		1134-5455-01	Schalldämpfer	Muffler			
23B			1	1134-5456-01	Schalldämpfer	Muffler			
24	1	1	1	9739-0831-22	Mutter	Nut			
25	1	1	1	9959-0820-16	Schraube	Screw			
26	1	1	1	1134-5457-01	Wärmeschutz	Heat guard			
27	4	4	4	9893-0616-16	Schraube	Screw			

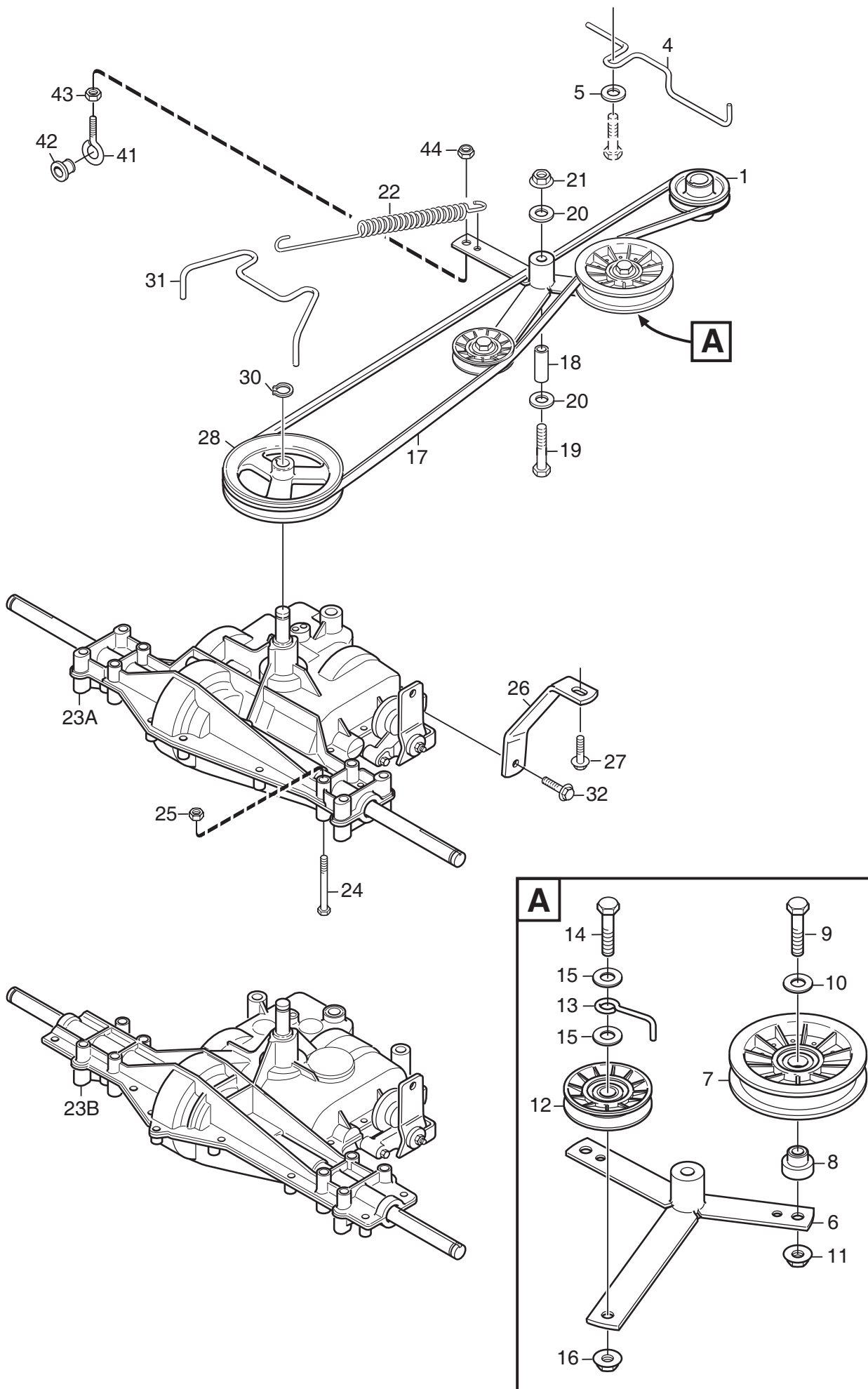

Ausgabe Issue 2008-31		Bild Nr Picture No C079A		XM 130 TRANSMISSION		XM 130 TRANSMISSION		Seite Page 50	
Pos. Fig.	Anzahl/Quantity				Artikel Nr. Part No	Bezeichnung	Description	Satz Kit	Anmerkung Notes
	2781 -88								
1	1				1134-4611-01	Motorriemenscheibe.....	Engine belt pulley.....		
4	1				1134-5414-01	Riemenführung.....	Belt guide.....		
5	1				9699-0056-02	Scheibe.....	Flat washer.....		
6	1				1134-4519-01	Spannarm.....	Tension arm.....		
7	1				1134-3053-01	Spannrolle.....	Tension roller.....		
8	1				1134-4614-01	Ansatzdistanz.....	Shoulder spacer.....		
9	1				9997-1040-16	Schraube.....	Screw.....		
10	1				9699-0035-02	Scheibe.....	Flat washer.....		
11	1				9739-1031-22	Mutter.....	Nut.....		
12	1				1134-2989-02	Spannrolle- grau.....	Tension roller- grey.....		
13	1				1134-1795-01	Riemenbügel.....	Belt stirrup.....		
14	1				9997-1040-16	Schraube.....	Screw.....		
15	2				9699-0035-02	Scheibe.....	Flat washer.....		
16	1				9739-1031-22	Mutter.....	Nut.....		
17	1				9585-0124-01	Keilriemen.....	V- belt.....		
18	1				1134-1565-08	Distanz.....	Spacer.....		
19	1				9997-0870-16	Schraube.....	Screw.....		
20	2				9699-0056-02	Scheibe.....	Flat washer.....		
21	1				9739-0831-22	Mutter.....	Nut.....		
22	1				1134-5214-01	Feder.....	Spring.....		
23A	1				1134-5281-01	Getriebe Kpl.....	Transaxle assy.....		Dana 4360- 197
23B	1				1134-6338-01	Getriebe Kpl.....	Transaxle assy.....		Dana 6800- 7
24	4				9960-0860-12	Schraube.....	Screw.....		
25	4				9747-0831-02	Mutter.....	Lock nut.....		
26	1				1134-4687-01	Strebe.....	Strut.....		
27	1				9945-0816-16	Schraube.....	Screw.....		
28	1				1134-1849-01	Riemenscheibe.....	Belt pulley.....		
30	1				9650-0016-04	Seegersicherung.....	Lock ring.....		
31	1				1134-4707-01	Riemenführung.....	Belt guide.....		
32	1				9942-0820-16	Schraube.....	Screw.....		
41	1				1134-2138-01	Schrauböse.....	Eye bolt.....		
42	1				1134-4779-01	Plastikbuchse.....	Plastic bushing.....		
43	1				9739-0831-22	Mutter.....	Nut.....		
44	1				9747-0831-02	Mutter.....	Lock nut.....		

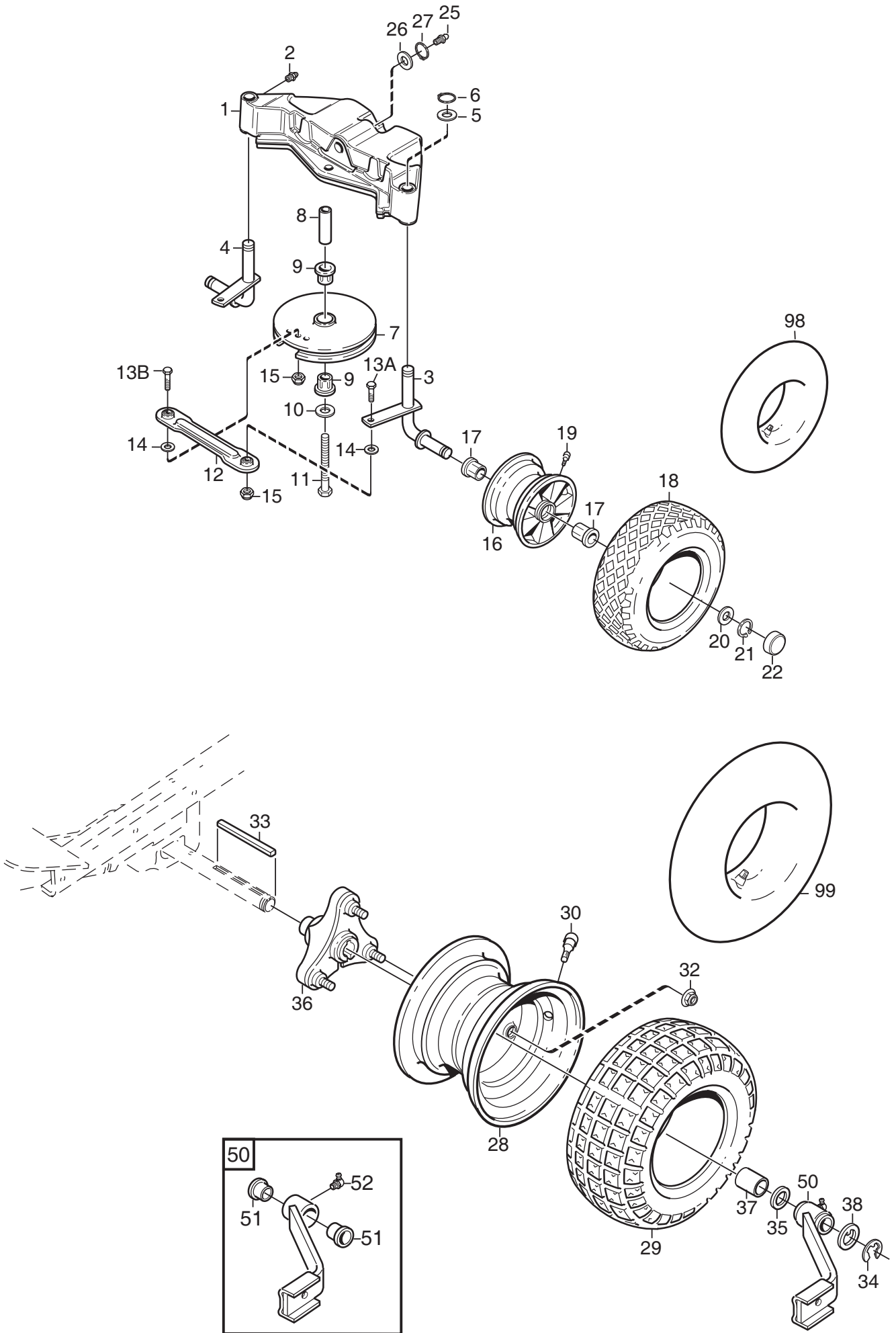

C081B

Ausgabe Issue 2008-31		Bild Nr Picture No C081B		XM 130 XM 140 HD- XM 160 HD RÄDER		XM 130 XM 140 HD- XM 160 HD WHEELS		Seite Page 54	
Pos. Fig.	Anzahl/Quantity			Artikel Nr. Part No	Bezeichnung	Description	Satz Kit	Anmerkung Notes	
	2781 -88	2782 -38 -88	2783 -38 -88						
1	1	1	1	1134-5894-01	Hinterachse	Rear axle			
2	2	2	2	9501-0500-00	Schmiernippel	Grease joint			
3	1	1	1	1134-5009-02	Spindel- L	Spindle- LH			
4	1	1	1	1134-5009-01	Spindel- R	Spindle- RH			
5	2	2	2	9699-0088-02	Scheibe.....	Flat washer.....			
6	2	2	2	9650-0020-04	Seegersicherung.....	Circlip.....			
7	1	1	1	1134-5316-01	Lenkdrahtscheibe	Steering pulley			
8	1	1	1	1134-5575-01	Distanz.....	Spacer.....			
9	2	2	2	1134-0068-00	Lager	Bearing.....			
10	1	1	1	9699-0104-02	Scheibe.....	Washer.....			
11	1	1	1	9997-1680-12	Schraube	Screw.....			
12	2	2	2	1134-3247-05	Spurstange.....	Tie rod.....			
13A	2	2	2	9997-0825-16	Schraube	Screw.....		L = 25 mm	
13B	1	1	1	9997-0835-12	Schraube	Screw.....		L = 35 mm	
14	2	2	2	9699-0090-02	Scheibe.....	Flat washer.....			
15	3	3	3	9747-0831-02	Mutter.....	Lock nut.....			
16	2	2	2	1134-4706-01	Felge	Rim			
17	4	4	4	1134-1319-01	Lagerbuchse.....	Bearing bush.....			
18	2	2	2	9545-0117-00	Reifen	Tyre		13 x 5.00 - 6	
19	2	2	2	9545-0500-00	Ventil	Valve			
20	2	2	2	1134-0341-01	Scheibe.....	Washer.....			
21	2	2	2	9650-0020-04	Seegersicherung.....	Circlip.....			
22	2	2	2	1134-4344-01	Nabekapsel.....	Hub cap.....			
25	1	1	1	9501-0500-00	Schmiernippel	Grease joint.....			
26	1	1	1	9699-0088-02	Scheibe.....	Flat washer.....			
27	1	1	1	9650-0020-04	Seegersicherung.....	Circlip.....			
28	2	2	2	1134-5255-01	Felge.....	Rim			
29	2	2	2	9545-0126-01	Reifen	Tyre		16 x 6.00 - 8	
30	2	2	2	9545-0500-00	Ventil	Valve			
32	6	6	6	9731-1031-22	Mutter.....	Nut			
33	2	2	2	1134-2471-03	Keil	Key.....			
34	2	2	2	9653-0001-04	Schließring	Lock ring.....			
35	2	2	2	1134-0341-01	Scheibe.....	Washer.....			
36	2	2	2	1134-4844-02	Radnabe	Wheel hub.....			
37	2	2	2	1134-4845-02	Nabenhülse.....	Hub sleeve			
38	2	2	2	1134-4981-01	Scheibe.....	Washer.....			
50	2	2	2	1134-6274-01	Geräthalter kpl	Attachment assy			
51	2	2	2	1134-1319-01	• Lagerbuchse.....	• Bearing bush.....			
52	1	1	1	9501-0502-00	• Schmiernippel.....	• Grease joint.....			
98				9545-0204-00	Innenschlauch	Inner tube		Only as spare part	
99				9545-0203-00	Innenschlauch	Inner tube		Only as spare part	

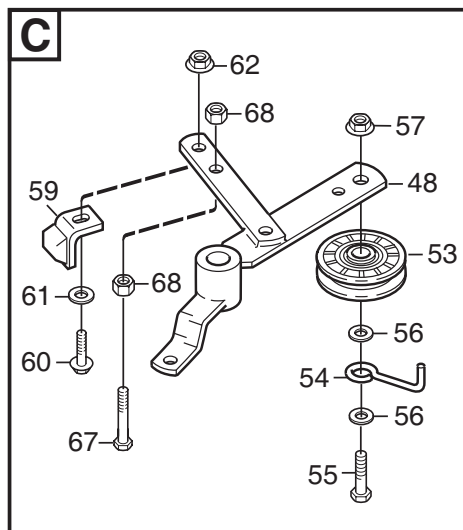
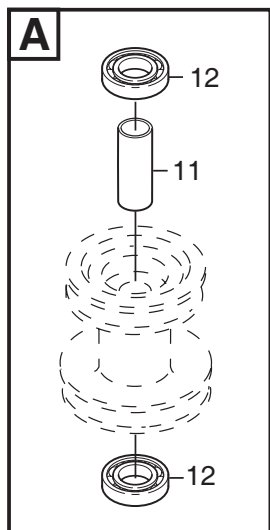
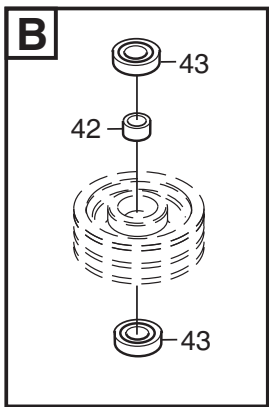
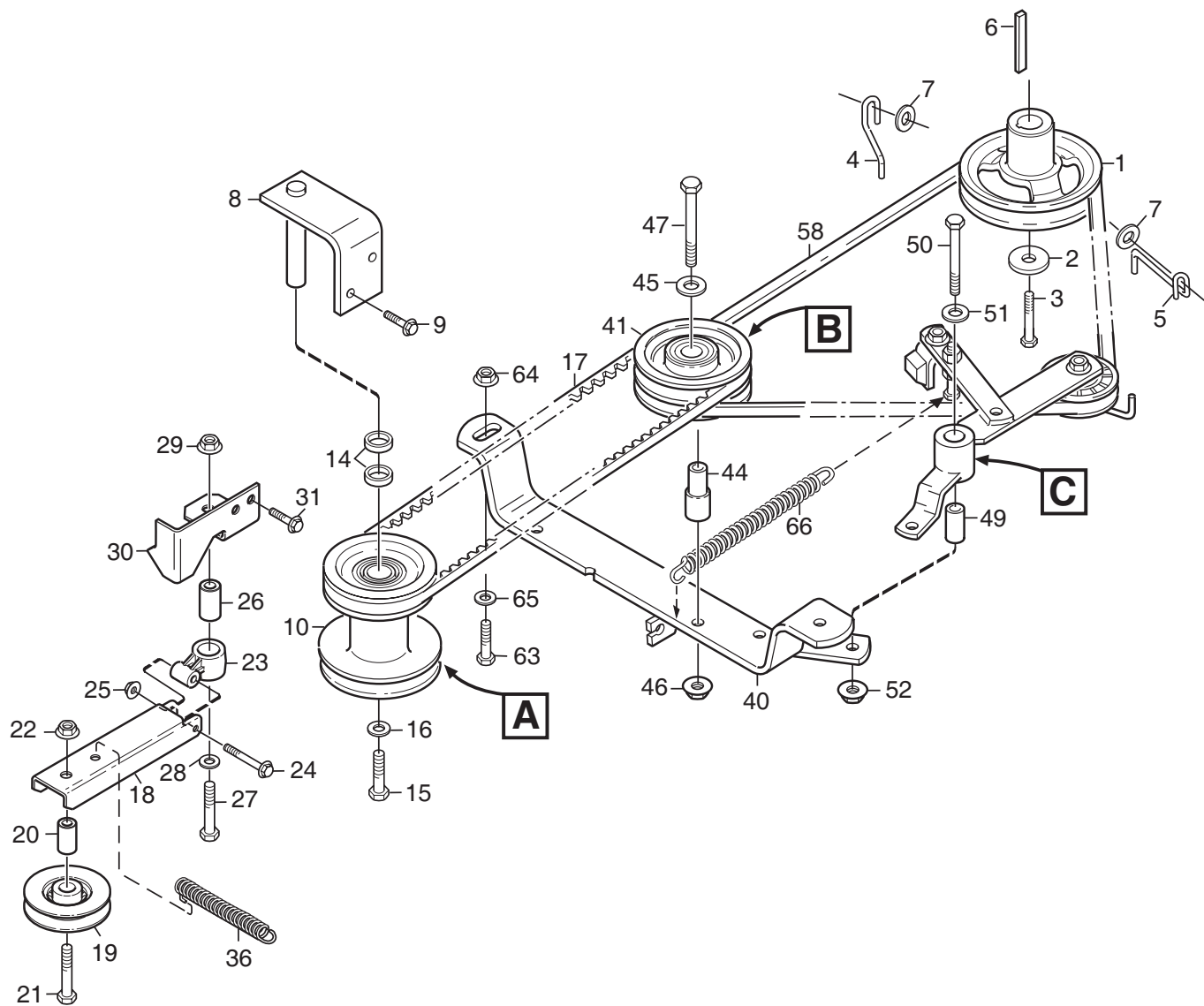

Ausgabe Issue 2008-31		Bild Nr Picture No C082D		XM 130 XM 140 HD- XM 160 HD NEBENANTRIEB		XM 130 XM 140 HD- XM 160 HD POWER TAKE OFF		Seite Page 56	
Pos. Fig.	Anzahl/Quantity			Artikel Nr. Part No	Bezeichnung	Description	Satz Kit	Anmerkung Notes	
	2781 -88	2782 -38 -88	2783 -38 -88						
1	1	1	1	1134-5046-01	Motorriemenscheibe.....	Engine belt pulley.....		L = 2 1/2"	
2	1	1	1	1134-5017-01	Scheibe.....	Washer.....			
3	1	1	1	9987-5332-16	Schraube.....	Screw.....			
4	1	1	1	1134-5058-01	Riemenführung.....	Belt guide.....			
5	1	1	1	1134-5057-01	Riemenführung.....	Belt guide.....			
6	1	1	1	9600-0251-01	Keil.....	Key.....			
7	2	2	2	9699-0056-02	Scheibe.....	Flat washer.....			
8	1	1	1	1134-4650-01	Riemenscheibebügel.....	Pulley bracket.....			
9	2	2	2	9945-0816-16	Schraube.....	Screw.....			
10	1	1	1	1134-4643-01	Zwischenriemenscheibe.....	Intermediate pulley.....	Pos 11 - 12 incl.		
11	1	1	1	1134-0051-12	• Distanz.....	• Spacer.....			
12	2	2	2	9549-0019-00	• Kugellager.....	• Ball bearing.....			
14	2	2	2	1134-0052-00	Lagerdistanz.....	Bearing spacer.....			
15	1	1	1	9997-1040-16	Schraube.....	Screw.....			
16	1	1	1	9699-0035-02	Scheibe.....	Flat washer.....			
17	1	1	1	9585-0139-01	Keilriemen.....	V-belt.....			
18	1	1	1	1134-5231-01	Spannarm.....	Tension arm.....			
19	1	1	1	1134-6329-01	Spannrolle.....	Tension roller.....			
20	1	1	1	1134-4619-01	Distanz.....	Spacer.....			
21	1	1	1	9997-1060-12	Schraube.....	Screw.....			
22	1	1	1	9731-1031-22	Mutter.....	Nut.....			
23	1	1	1	1134-6314-01	Halterung.....	Attachment.....			
24	1	1	1	9997-0640-12	Schraube.....	Screw.....			
25	1	1	1	9747-0631-02	Mutter.....	Lock nut.....			
26	1	1	1	1134-4619-01	Distanz.....	Spacer.....			
27	1	1	1	9930-1050-12	Schraube.....	Screw.....			
28	1	1	1	9699-0035-02	Scheibe.....	Flat washer.....			
29	1	1	1	9731-1031-22	Mutter.....	Nut.....			
30	1	1	1	1134-4708-02	Halterung.....	Bracket.....			
31	2	2	2	9945-0816-16	Schraube.....	Screw.....			
36	1	1	1	1131-1507-00	Feder.....	Spring.....			
40	1	1	1	1134-5037-01	Bügel.....	Bracket.....			
41	1	1	1	1134-1769-03	Riemenscheibe Kpl.....	Centre pulley assy.....	Pos 42 - 43 incl.		
42	1	1	1	1134-0051-09	• Distanz.....	• Spacer.....			
43	2	2	2	9549-0019-00	• Kugellager.....	• Ball bearing.....			
44	1	1	1	1134-1839-02	Achse.....	Shaft.....			
45	1	1	1	9699-0035-02	Scheibe.....	Flat washer.....			
46	1	1	1	9739-1031-22	Mutter.....	Nut.....			
47	1	1	1	9997-1070-12	Schraube.....	Screw.....			
48	1	1	1	1134-5541-01	Kupplungsarm.....	Clutch lever.....			
49	1	1	1	1134-1565-10	Distanz.....	Spacer.....			
50	1	1	1	9997-0860-16	Schraube.....	Screw.....			
51	1	1	1	9699-0056-02	Scheibe.....	Flat washer.....			
52	1	1	1	9739-0831-22	Mutter.....	Nut.....			
53	1	1	1	1134-2989-02	Spannrolle- grau.....	Tension roller- grey.....			
54	1	1	1	1134-1795-01	Riemenbügel.....	Belt stirrup.....			
55	1	1	1	9997-1040-16	Schraube.....	Screw.....			
56	2	2	2	9699-0035-02	Scheibe.....	Flat washer.....			
57	1	1	1	9739-1031-22	Mutter.....	Nut.....			
58	1	1	1	9585-0138-01	Keilriemen.....	V-belt.....			
59	1	1	1	1134-4164-03	Bremsklotz.....	Brake pad.....			
60	1	1	1	9959-0820-16	Schraube.....	Screw.....			
61	1	1	1	9699-0090-02	Scheibe.....	Flat washer.....			
62	1	1	1	9747-0831-02	Mutter.....	Lock nut.....			
63	2	2	2	9959-0820-16	Schraube.....	Screw.....			
64	2	2	2	9739-0831-22	Mutter.....	Nut.....			
65	1	1	1	9699-0056-02	Scheibe.....	Flat washer.....			
66	1	1	1	1131-1506-00	Feder.....	Spring.....			
67	1	1	1	9997-0860-16	Schraube.....	Screw.....			
68	2	2	2	9739-0831-22	Mutter.....	Nut.....			

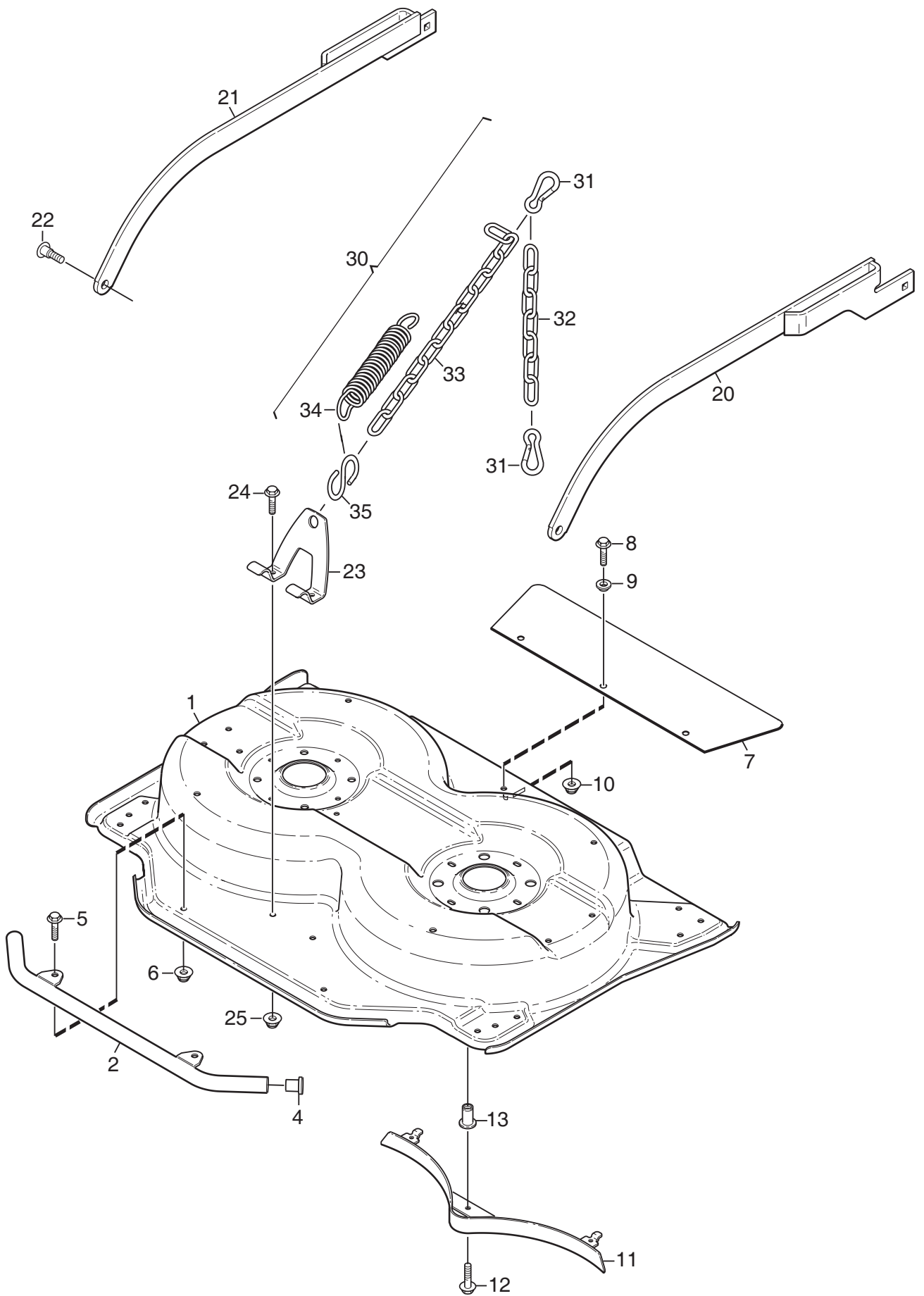

Ausgabe Issue 2008-31		Bild Nr Picture No C123		XM MÄHWERK 85C RAHMEN		XM MOWER DECK 85C FRAME		Seite Page 58		
Pos. Fig.	Anzahl/Quantity				Artikel Nr. Part No	Bezeichnung	Description	Satz Kit	Anmerkung Notes	
	2960	-42	-82							
1	1				1134-6189-03	Haube- rot.....	Casing- red.....		Pos 13 incl.	
2	1				1134-6208-02	Frontschutz- schwarz.....	Front guard tube- bl.			
4	2				9403-0025-70	Propfen- schwarz.....	End cap- black.....			
5	2				9959-0816-16	Schraube	Screw			
6	2				9739-0831-22	Mutter	Nut			
7	1				1134-6281-01	Gummischutz	Rubber guard			
8	3				9959-0816-16	Schraube	Screw			
9	3				1134-4185-01	Flanschscheibe	Flange washer			
10	3				9739-0831-22	Mutter	Nut			
11	1				1134-6227-01	Mulchpropfen	Mulching plug			
12	1				9959-0816-16	Schraube	Screw			
13	1				1134-5595-01	• Nietmutter.....	• Riveting nut.....			
20	1				1134-6237-11	Mähwerkarm- L, schw	Deck arm- LH, black			
21	1				1134-6237-12	Mähwerkarm- R, schw	Deck arm- RH, black			
22	2				1134-6279-01	Schulter-schraube.....	Shoulder bolt			
23	1				1134-6315-02	Hebehalter- schw	Lift bracket- black.....			
24	2				9959-0816-16	Schraube	Screw			
25	2				9739-0831-22	Mutter	Nut			
30	1				1134-6363-01	Hebefeder kpl	Lift spring assy			
31	2				1134-5528-01	• Karabinerhaken.....	• Snap hook			
32	1				1134-6368-02	• Kette	• Chain			
33	1				1134-6368-03	• Kette	• Chain			
34	1				1134-5625-01	• Mähwerkfeder.....	• Mower deck spring			
35	1				1134-4623-01	• S- Haken	• S- hook.....			
99	1				8211-7080-81	Bedienungsanleitung	Owner's manual			
										Pos 31 - 35 incl.
										7 links 12 links
										Not ill.

X

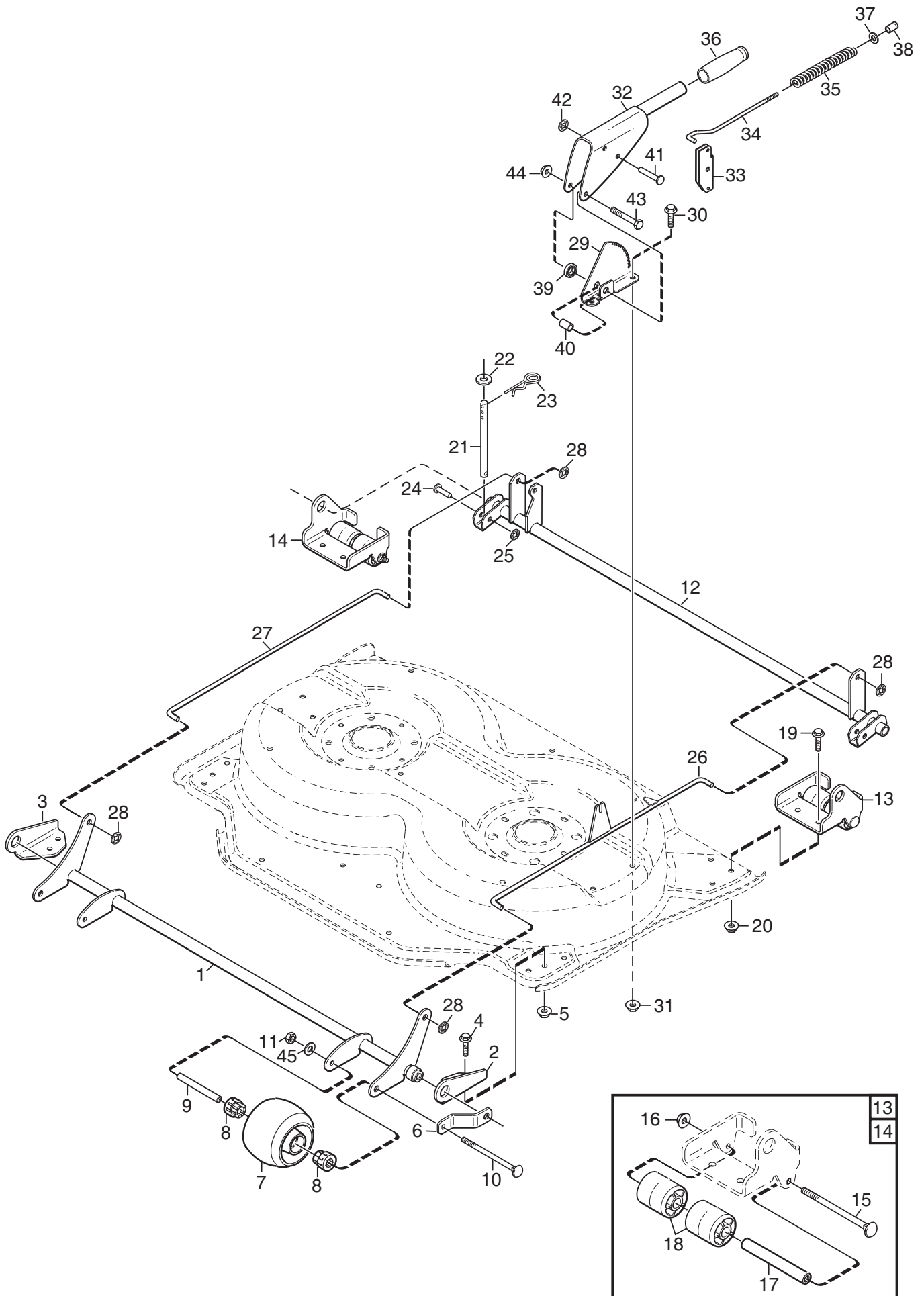

Ausgabe Issue 2008-31		Bild Nr Picture No C124		XM MÄHWERK 85C REGULIERUNGEN		XM MOWER DECK 85C CONTROLS		Seite Page 60	
Pos. Fig.	Anzahl/Quantity				Artikel Nr. Part No	Bezeichnung	Description	Satz Kit	Anmerkung Notes
	2960	-42	-82						
1	1				1134-6275-02	Vorderachse- schwarz	Front axle- black.....		
2	1				1134-6214-03	Halter- L, schwarz.....	Bracket fr- LH, black.....		
3	1				1134-6214-04	Halter- R, schwarz	Bracket fr- RH, black		
4	4				9959-0816-16	Schraube	Screw		
5	4				9739-0831-22	Mutter	Nut		
6	2				1134-6278-02	Leitblech- schwarz.....	Guide- black		
7	2				1134-4284-01	Rad	Wheel		
8	4				1134-4319-01	Lager	Bearing.....		
9	2				1134-4318-01	Radachse.....	Wheel axle.....		
10	2				9897-0813-02	Schraube	Screw		
11	2				9747-0831-02	Mutter.....	Lock nut.....		
12	1				1134-6197-02	Hinterachse- schwarz	Rear axle- black		
13	1				1134-6282-01	Rollen- L, m.Halter.....	Roller- LH, w/bracket		Pos 15 - 18 incl.
14	1				1134-6282-02	Rollen- R, m.Halter	Roller- RH, w/bracket.....		Pos 15 - 18 incl.
15	1				9897-0813-02	• Schraube	• Screw		
16	1				9739-0831-22	• Mutter	• Nut		
17	1				1134-4318-01	• Radachse.....	• Wheel axle.....		
18	2				1134-6206-01	• Rollen	• Roller		
19	4				9959-0816-16	Schraube	Screw		
20	4				9739-0831-22	Mutter	Nut		
21	2				1134-6198-01	Stange	Stud		
22	2				9699-0104-02	Scheibe.....	Washer.....		
23	2				9598-2001-02	Schließnadel	Spring pin		
24	2				9646-0098-22	Niet.....	Rivet.....		
25	2				9675-0012-02	Verriegelungsscheibe	Locking washer.....		
26	1				1134-6249-03	Druckstange- L	Push rod- LH.....		
27	1				1134-6246-03	Druckstange- R.....	Push rod- RH		
28	4				9675-0015-02	Verriegelungsscheibe	Lock washer.....		
29	1				1134-6255-01	Höhenverstellsektor.....	Height adj. quadrant.....		
30	2				9959-0816-16	Schraube	Screw		
31	2				9739-0831-22	Mutter	Nut		
32	1				1134-6244-02	Höhenverst.hebel- schw	Height adj.lever- bl.		
33	1				1134-6254-01	Sperre.....	Catch.....		
34	1				1134-5444-01	Druckstange	Push rod		
35	1				1134-5445-01	Feder	Spring		
36	1				1134-5503-01	Griff	Handle.....		
37	1				9699-0087-02	Scheibe.....	Flat washer.....		
38	1				1134-3051-01	Sperrknopf.....	Locking knob		
39	1				1134-6286-03	Distanz.....	Spacer.....		
40	1				1134-1565-16	Distanz.....	Spacer.....		
41	2				9646-0105-22	Niet.....	Rivet.....		
42	2				9672-0006-02	Verriegelungsscheibe	Lock washer		
43	1				9997-0850-16	Schraube	Screw		
44	1				9747-0831-02	Mutter.....	Lock nut.....		
45	2				9699-0028-02	Scheibe.....	Flat washer.....		

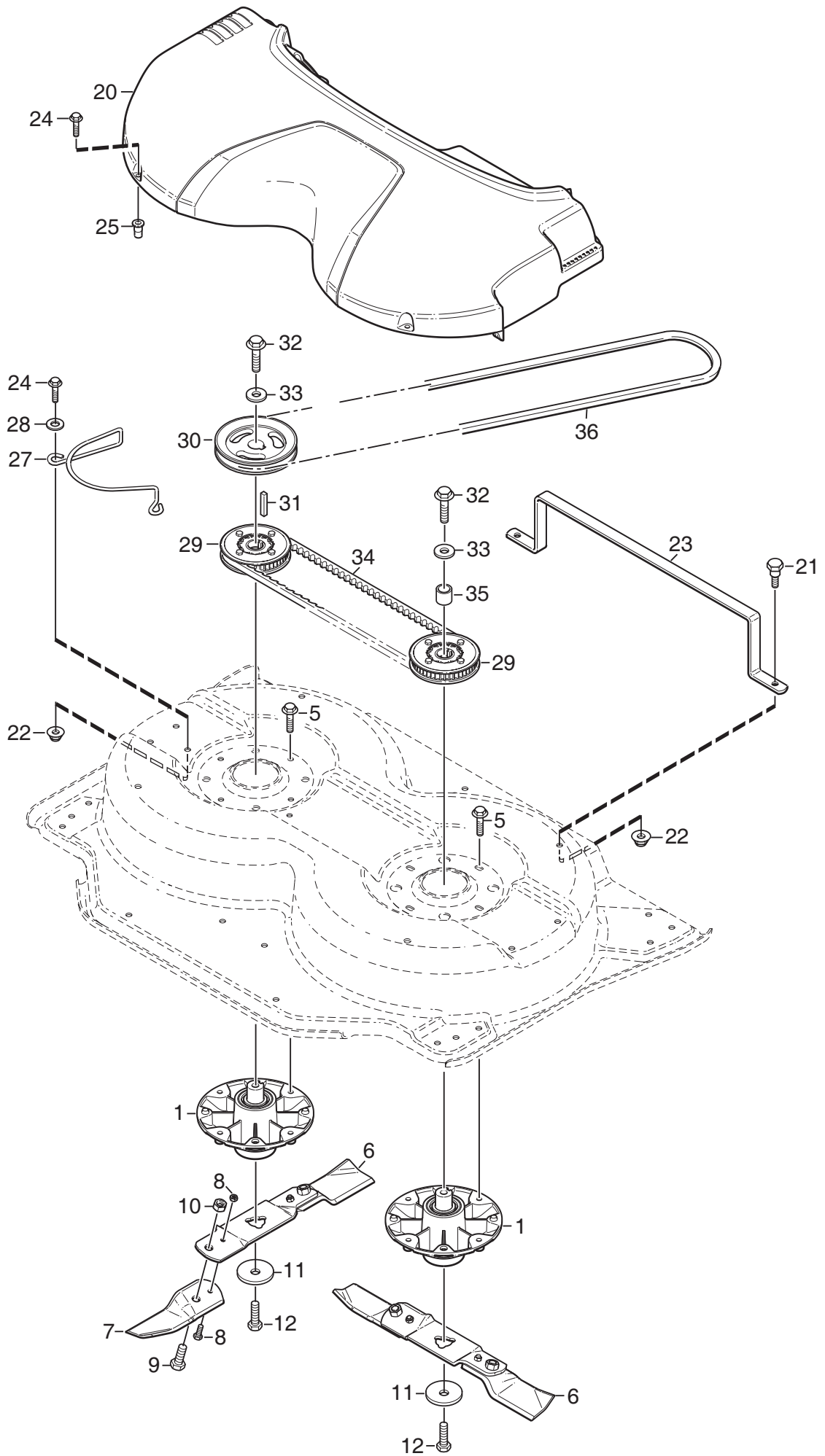

Ausgabe Issue 2008-31		Bild Nr Picture No C125		XM MÄHWERK 85C TRANSMISSION	XM MOWER DECK 85C TRANSMISSION	Seite Page 62			
Pos. Fig.	Anzahl/Quantity				Artikel Nr. Part No	Bezeichnung	Description	Satz Kit	Anmerkung Notes
	2960 -42 -82								
1	2			1134-5831-01	Lagerbuchse kpl	Bearing box assy.....			
5	8			9945-0825-16	Schraube	Screw			
6	2			1134-6240-01	Messer kpl.....	Blade bar assy.....			Pos 7 incl.
7	1			1134-9119-01	• Messersatz	• Blade kit			Pos 8 - 10 incl.
8	1			1134-9054-01	•• Scherbolzensatz.....	•• Shear bolt kit.....			
9	2			1134-6311-01	•• Bolt	•• Bolt.....			7/16" UNF
10	2			1134-6312-01	•• Schloßmutter	•• Lock nut			7/16" UNF
11	2			1134-6211-01	Messerscheibe.....	Blade washer.....			
12	2			9997-1060-12	Schraube	Screw.....			
20	1			1134-6280-03	Deckel- grau.....	Transm.cover- grey			
21	2			1134-0240-01	Schulter-schraube.....	Shoulder screw			
22	4			9739-0831-22	Mutter	Nut			
23	1			1134-6423-01	Bügel	Bracket			
24	4			9945-0825-16	Schraube	Screw			
25	2			1134-5595-01	Nietmutter	Riveting nut.....			
27	1			1134-6429-01	Riemenführung.....	Belt guide			
28	2			9699-0090-02	Scheibe.....	Flat washer.....			
29	2			1134-6287-01	Zahnriemenscheibe	Toothed belt pulley.....			
30	1			1134-6201-01	Riemenscheibe	Belt pulley			Ø = 154 mm
31	1			9600-0168-01	Keil	Key			
32	2			9997-1060-12	Schraube	Screw			
33	2			1134-5406-01	Scheibe.....	Washer.....			
34	1			9585-0161-01	Zahnriemen	Toothed belt			
35	1			1134-5400-04	Distanz.....	Spacer.....			
36	1			9585-0154-01	Keilriemen	V- belt.....			