

PARTS LIST

CHAIN SAWS

G410AVS
G455AVS

APPLICABLE SERIAL NUMBERS:

G410AVS — 508501 and up
G455AVS — 514001 and up

JANUARY 1995

Fig. 1 ENGINE BLOCK, MUFFLER

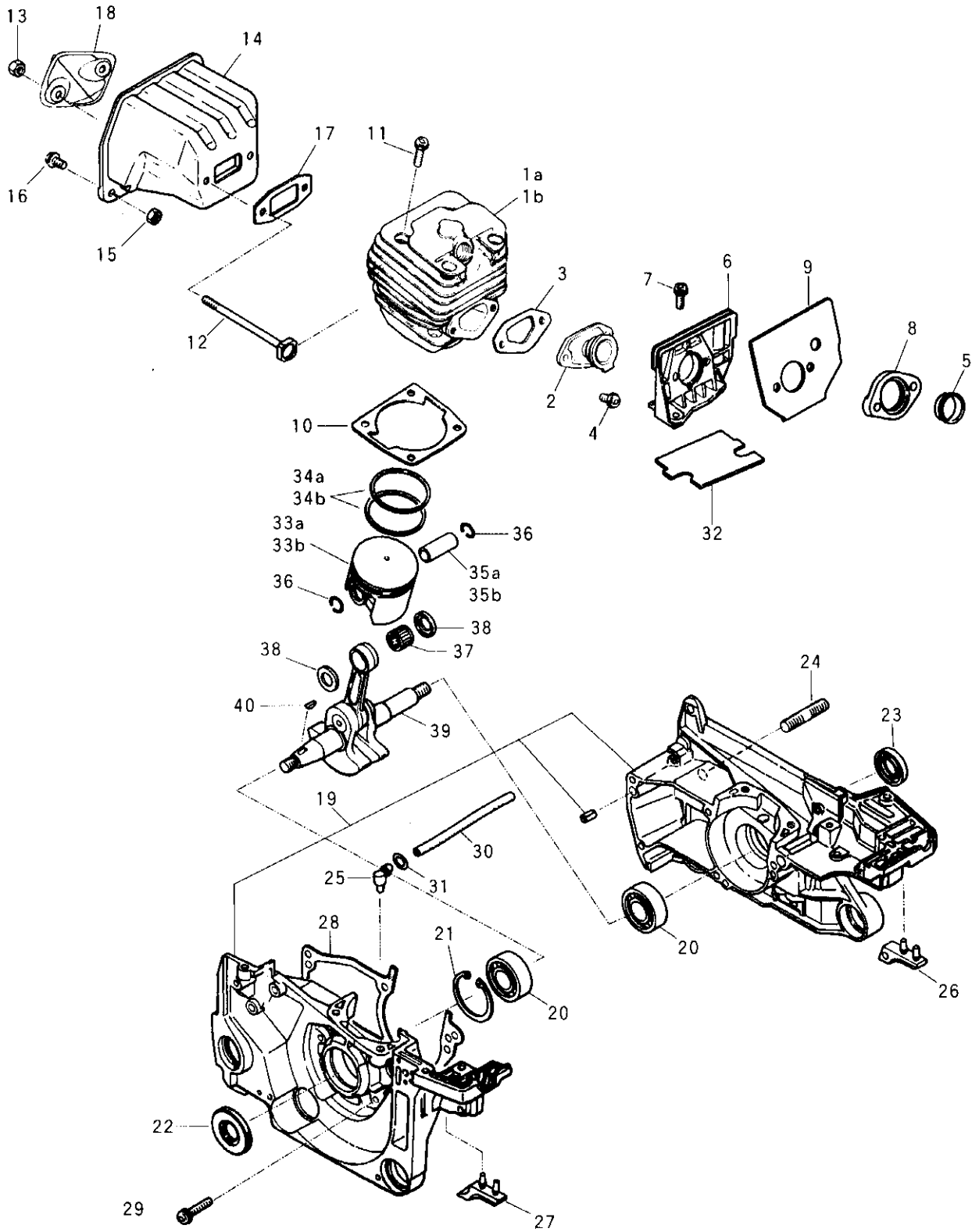

Fig. 1 ENGINE BLOCK, MUFFLER

Key#	PART NUMBER	DESCRIPTION	Q'TY/UNIT		NOTE	Key#	PART NUMBER	DESCRIPTION	Q'TY/UNIT		NOTE
			G410	G455					G410	G455	
1a	2660-12112	CYLINDER	1	—		30	2810-22210	PIPE	1	1	
1b	2670-12112	CYLINDER	—	1		31	3310-82230	CLIP	1	1	
2	2810-14110	INLET PIPE	1	1		32	2810-22410	MAT	1	1	
3	2817-14120	GASKET	1	1	† 1	33a	2660-41113	PISTON	1	—	
4	2670-14130	SCREW	2	2		33b	2670-41113	PISTON	—	1	
5	2880-14150	GUIDE	1	1		34a	2660-41211	RING	2	—	
6	2670-14311	BRACKET	1	1		34b	2670-41211	RING	—	2	
7	2670-14320	SCREW	2	2		35a	2660-41310	PIN	1	—	
8	2880-14350	SPACER	1	1		35b	3350-41310	PIN	—	1	
9	2880-14360	GASKET	1	1		36	3350-41320	SNAP RING	2	2	
10	2670-14210	GASKET	1	1	† 1	37	1400-41410	BEARING	1	1	
11	2850-14220	BOLT	4	4		38	2670-41510	WASHER	2	2	
12	2810-15220	BOLT	2	2		39	2880-42001	CRANKSHAFT COMP.	1	1	
13	2850-15230	NUT	2	2		40	1000-43240	KEY	1	1	
14	2823-15113	MUFFLER	1	1							
15	0280-10504	NUT	2	2							
16	2670-14130	SCREW	2	2							
17	3356-15210	GASKET	1	1	† 1						
18	2810-15310	COVER	1	1							
19	2810-21007	CRANKCASE ASS'Y	1	1							
20	2810-21240	BEARING	2	2							
21	04065-03515	SNAP RING	1	1							
22	2670-21210	SEAL	1	1							
23	2670-21220	SEAL	1	1							
24	2616-21230	STUD	2	2							
25	2670-21250	ELBOW	1	1							
26	2810-22511	STOPPER	1	1							
27	2810-22521	STOPPER	1	1							
28	2670-21310	GASKET	1	1	† 1						
29	2670-21320	SCREW	5	5							

† 1 Component of 2810-06012 GASKET KIT (Optional)

Fig. 2 IGNITION SYSTEM, STARTER

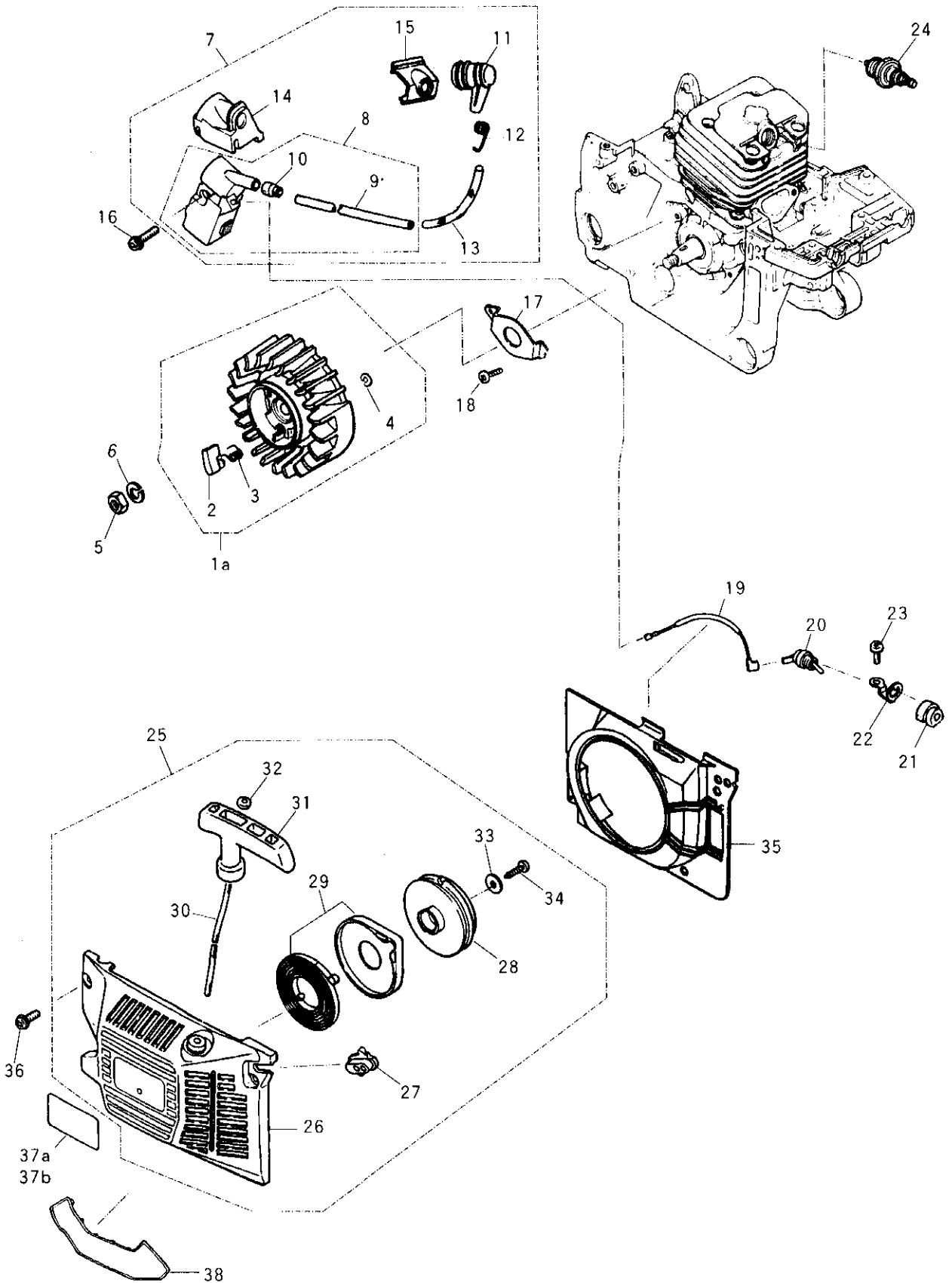

Fig. 2 IGNITION SYSTEM, STARTER

Key#	PART NUMBER	DESCRIPTION	Q'TY/UNIT		NOTE	Key#	PART NUMBER	DESCRIPTION	Q'TY/UNIT		NOTE
			G410	G455					G410	G455	
1	2670-71101	ROTOR ASS'Y	1	1		31	1400-75170	KNOB	1	1	
2	1850-75220	RATCHET	2	2		32	3310-75431	WASHER	1	1	
3	2670-71130	SPRING	2	2		33	1400-86280	WASHER	1	1	
4	0308-00040	RING	2	2		34	2670-35120	SCREW	1	1	
5	3350-43231	NUT	1	1		35	2670-75613	COVER	1	1	
6	0290-20820	WASHER	1	1		36	2670-14320	SCREW	4	4	
7	2810-71304	COIL ASS'Y	1	1		37a	2820-75131	LABEL	1	—	
8	2810-71204	COIL COMP.	1	1		37b	2810-75131	LABEL	—	1	
9	2810-71220	CORD	1	1		38	2881-98610	SNOW PROTECTOR	1	1	† 2
10	2670-71230	GROMMET	1	1							
11	2810-72110	CAP	1	1							
12	1400-72121	SPRING	1	1							
13	2670-71320	TUBE	1	1							
14	2670-71310	COVER	1	1							
15	2810-71250	GROMMET	1	1							
16	2670-14220	SCREW	2	2							
17	2810-21270	PLATE	1	1							
18	0260-30410	SCREW	2	2							
19	2670-71510	CORD	1	1							
20	2810-71610	SWITCH	1	1							
21	2670-71621	COVER	1	1							
22	2880-71630	PLATE	1	1							
23	2670-14130	SCREW	1	1							
24	3356-73110	SPARK PLUG	1	1	† 1						
25	2880-75001	STARTER ASS'Y	1	1							
26	2670-75113	CASE	1	1							
27	2810-75120	GUIDE	1	1							
28	2670-75211	REEL	1	1							
29	3317-75300	SPRING COMP.	1	1							
30	2670-75410	ROPE	1	1							

† 1 Champiopl CJ7Y

† 2 Optional part

Fig. 3 HANDLES

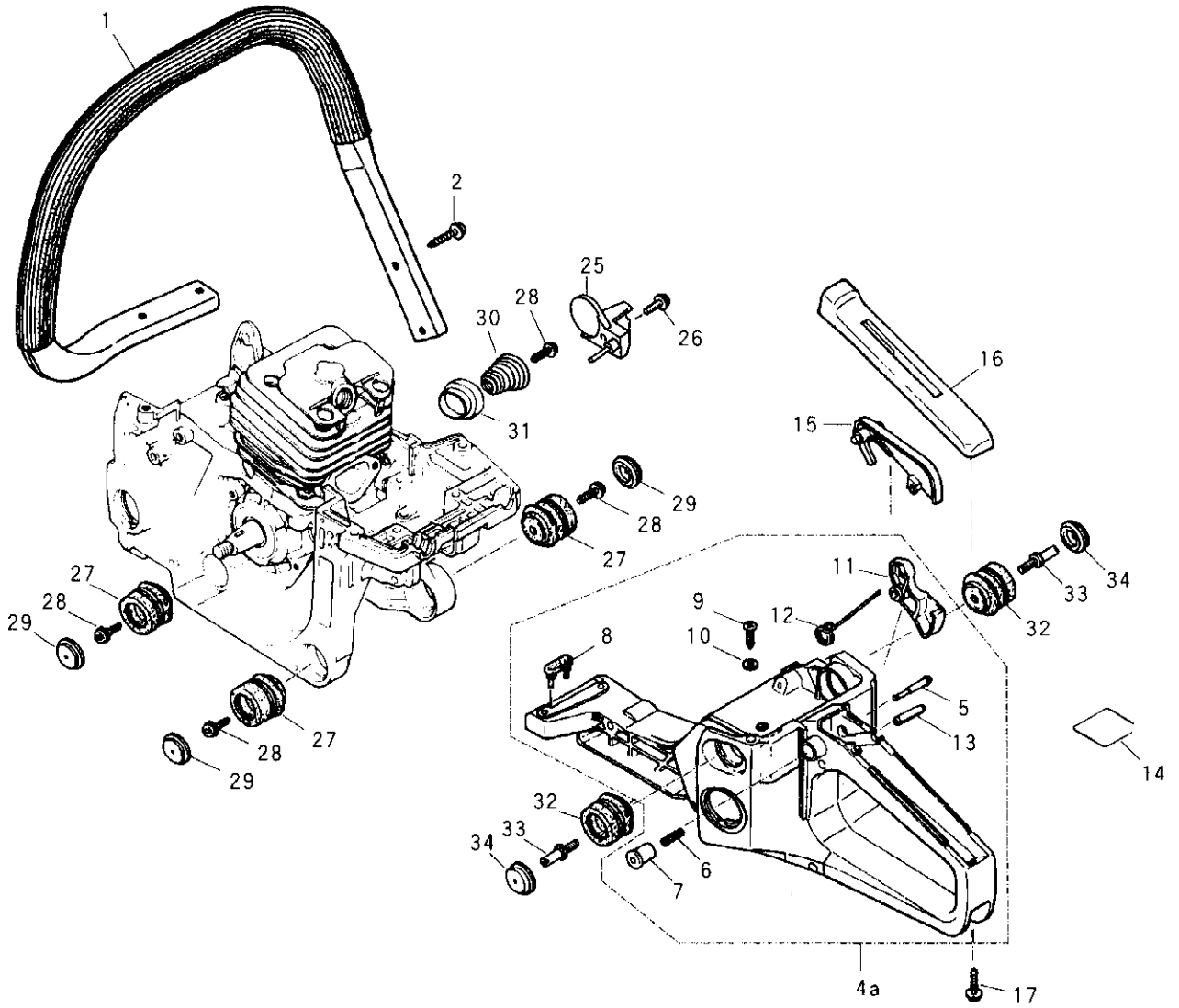

Fig. 3 HANDLE

Key#	PART NUMBER	DESCRIPTION	Q'TY/UNIT		NOTE	Key#	PART NUMBER	DESCRIPTION	Q'TY/UNIT		NOTE
			G410	G455					G410	G455	
1	2810-32100	LEFT HANDLE COMP.	1	1							
2	2671-32210	SCREW	4	4							
4	2810-33007	HANDLE ASS'Y	1	1							
5	3330-33250	STOPPER	1	1							
6	3310-33262	SPRING	1	1							
7	3310-33271	KNOB	1	1							
8	2810-33280	DAMPER (A)	1	1							
9	2670-75520	SCREW	1	1							
10	2810-33210	GASKET	1	1							
11	2670-33311	LEVER	1	1							
12	3356-33321	SPRING	1	1							
13	04025-00524	SPRING PIN	1	1							
14	2634-31420	LABEL	1	1							
15	3356-33351	ARM	1	1							
16	2670-34110	COVER	1	1							
17	2671-32210	SCREW	1	1							
25	2810-25210	CHAIN CATCHER	1	1							
26	2670-14320	SCREW	1	1							
27	2880-35111	DAMPER	3	3							
28	2670-35120	SCREW	4	4							
29	2810-35150	CAP	3	3							
30	2881-35110	SPRING	1	1							
31	2881-35120	SPACER	1	1							
32	2880-35211	DAMPER	2	2							
33	3350-35170	BOLT	2	2							
34	2880-35250	CAP	2	2							

Fig. 4 FUEL SUPPLY SYSTEM

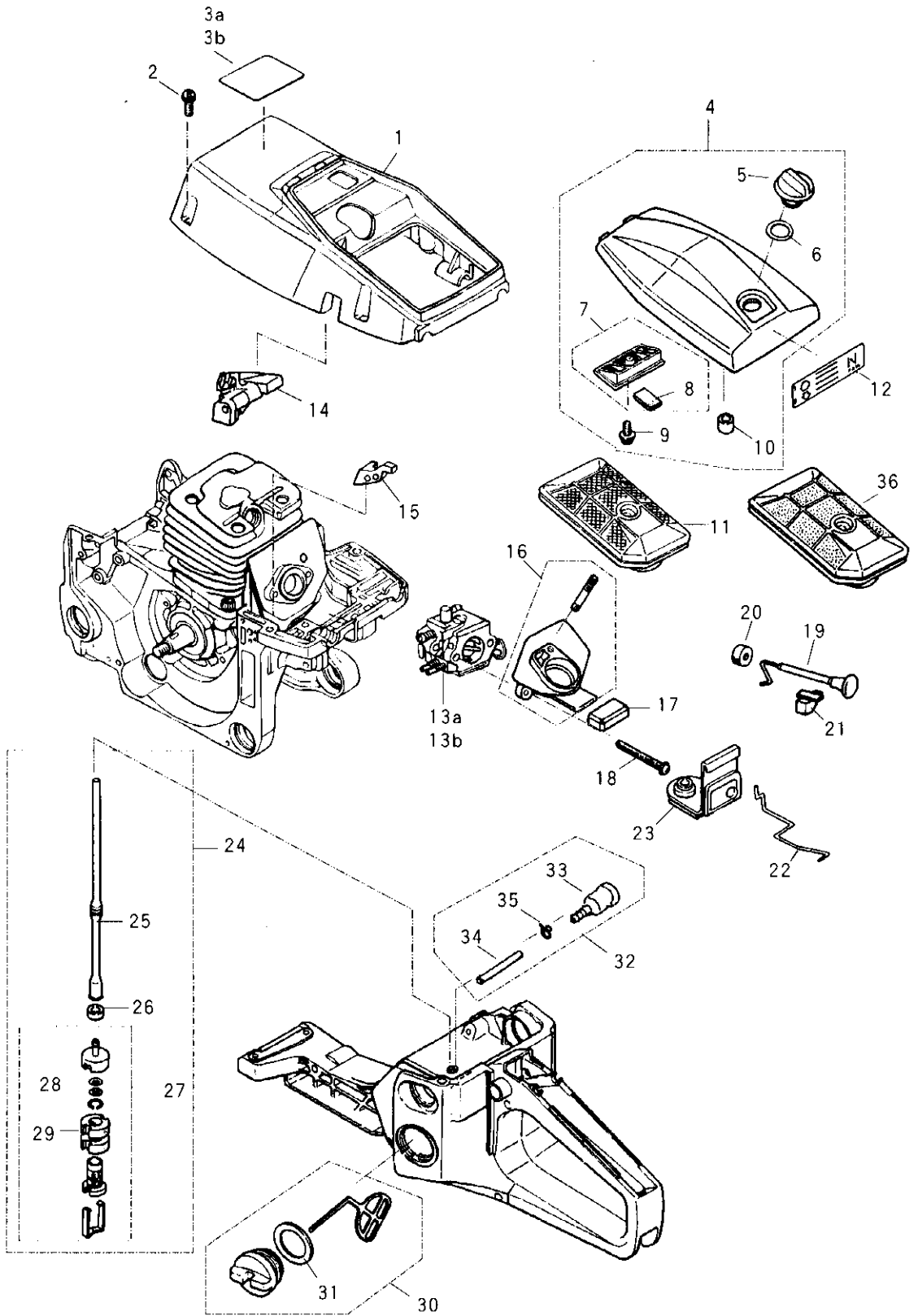

Fig. 4 FUEL SUPPLY SYSTEM

Key#	PART NUMBER	DESCRIPTION	Q'TY/UNIT		NOTE
			G410	G455	
1	2810-31115	CYLINDER COVER	1	1	
2	2670-14320	SCREW	5	5	
3a	2823-31420	LABEL	1	—	
3b	2813-31420	LABEL	—	1	
4	2810-83304	CLEANER COVER COMP.	1	1	
5	3356-83322	KNOB	1	1	
6	3388-83340	GASKET	1	1	
7	2810-83500	CLEANER COMP.	1	1	
8	2810-83520	SEAL	1	1	
9	1600-33130	SCREW	1	1	
10	2810-83410	GROMMET	1	1	
11	2810-83101	CLEANER COMP.	1	1	
12	2813-31210	LABEL	1	1	
13a	2823-81002	CARBURETOR ASS'Y	1	—	
13b	2813-81002	CARBURETOR ASS'Y	—	1	
14	2880-82310	GUIDE (I)	1	1	
15	2880-82350	GUIDE (H L)	1	1	
16	2880-82102	MANIFOLD COMP.	1	1	
17	2810-82141	SUPPORTER	1	1	
18	2880-82210	SCREW	2	2	
19	2880-82410	CHOKE ROD	1	1	
20	2670-82421	GROMMET	1	1	
21	2670-82430	GUIDE	1	1	
22	2880-82511	THROTTLE ROD	1	1	
23	2810-82520	GROMMET	1	1	
24	2810-34303	FUEL PIPE ASS'Y	1	1	
25	2810-34312	PIPE	1	1	
26	2810-34350	COLLAR	1	1	
27	3302-85400	FILTER ASS'Y	1	1	
28	3302-85420	SCREEN	2	2	

Key#	PART NUMBER	DESCRIPTION	Q'TY/UNIT		NOTE
			G410	G455	
29	3306-85450	FILTER	2	2	
30	2670-34401	TANK CAP ASS'Y	1	1	
31	2670-34430	GASKET	1	1	
32	2670-34500	BREATHER ASS'Y	1	1	
33	2670-34510	BREATHER	1	1	
34	3350-34540	PIPE	1	1	
35	1260-85460	CLIP	1	1	
36	2811-98501	CLEANER COMP.	1	1	† 1

† 1 Optional Part

Fig. 5 OIL FEED SYSTEM, CLUTCH, CARBURETOR

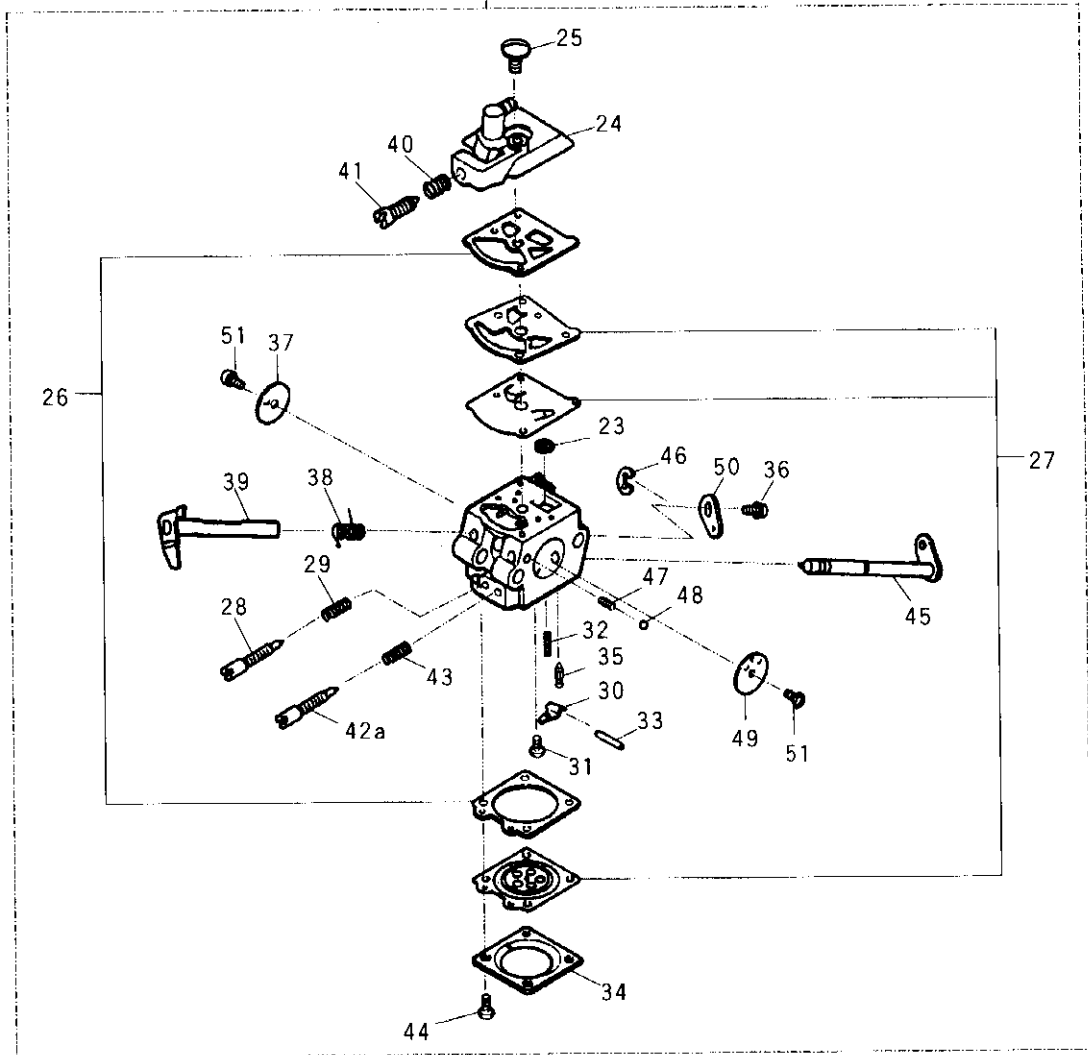
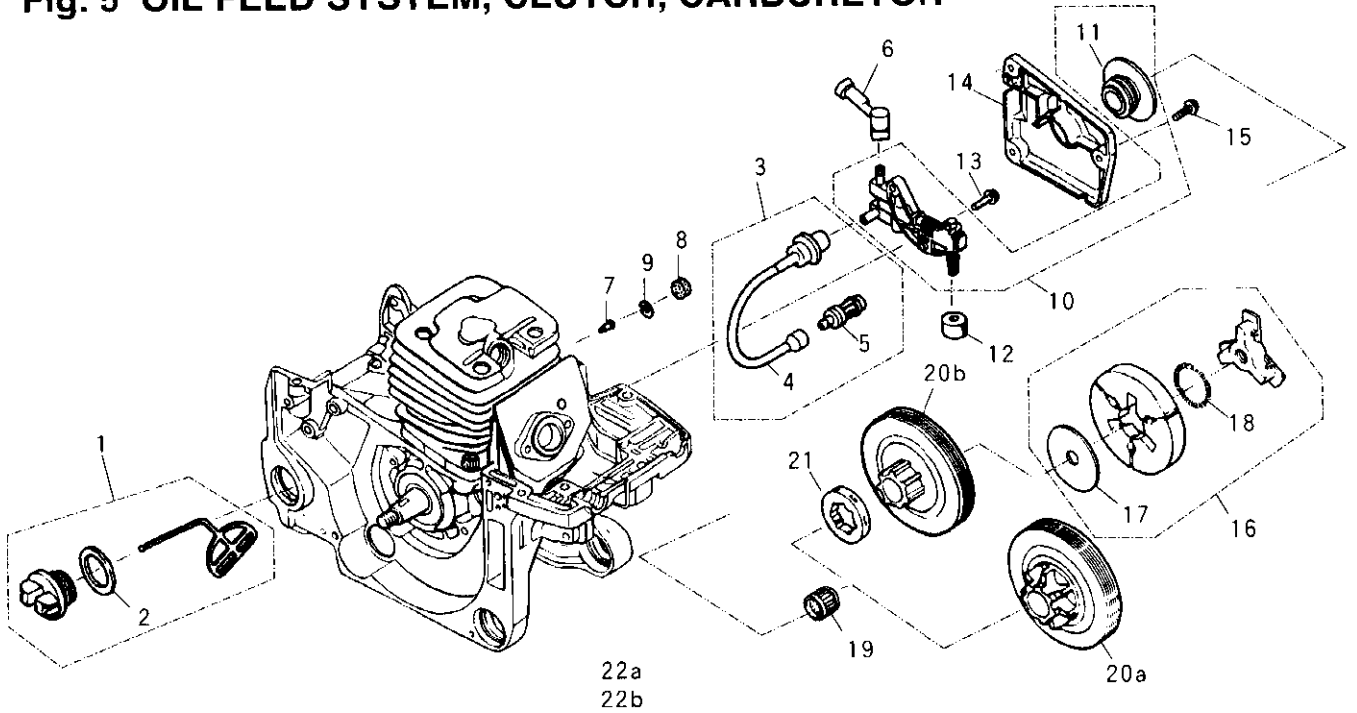

Fig. 5 OIL FEED SYSTEM, CLUTCH, CARBURETOR

Key#	PART NUMBER	DESCRIPTION	Q'TY/UNIT		NOTE	Key#	PART NUMBER	DESCRIPTION	Q'TY/UNIT		NOTE
			G410	G455					G410	G455	
1	2630-31801	CAP ASS'Y	1	1		30	3310-81230	LEVER	1	1	† 1
2	2630-31820	GASKET	1	1		31	3310-81240	SCREW	1	1	
3	2670-23101	OIL PIPE ASS'Y	1	1		32	1262-81270	SPRING	1	1	† 1
4	2670-23120	PIPE	1	1		33	3310-81250	PIN	1	1	† 1
5	2670-23131	FILTER	1	1		34	3310-81280	COVER	1	1	
6	2670-23210	PIPE	1	1		35	3356-81310	INLET VALVE	1	1	† 1
7	3330-23121	VALVE	1	1		36	3310-81360	SCREW	1	1	
8	3350-26220	SEAL	1	1		37	3356-81340	THROTTLE VALVE	1	1	
9	3350-26230	CLIP	1	1		38	2670-81410	SPRING	1	1	
10	2880-55100	OIL PUMP ASS'Y	1	1		39	2670-81420	THROTTLE SHAFT	1	1	
11	2670-55120	GEAR	1	1		40	2630-81460	SPRING	1	1	
12	2670-55220	SEAL	1	1		41	2670-81430	SCREW	1	1	
13	2670-55410	SCREW	2	2		42	2810-81331	HIGH SPEED NEEDLE	1	1	
14	2670-55610	COVER	1	1		43	3080-81320	SPRING	1	1	
15	2670-55410	SCREW	3	3		44	3310-81351	SCREW	4	4	
16	2670-51200	CLUTCH ASS'Y	1	1		45	2813-81460	CHOKE SHAFT	1	1	
17	2670-51210	PLATE	1	1		46	1148-81390	RING	1	1	
18	3317-51231	SPRING	1	1		47	3350-81350	SPRING	1	1	
19	2810-51310	BEARING	1	1		48	3350-81220	BALL	1	1	
20a	2672-51111	DRUM	1	—		49	2670-81450	CHOKE VALVE	1	1	
20b	2880-51110	DRUM	—	1		50	2810-81440	LEVER	1	1	
21	3350-51121	RIM	—	1		51	2880-81470	SCREW	2	2	
22a	2823-81002	CARBURETOR ASS'Y	1	—							
22b	2813-81002	CARBURETOR ASS'Y	—	1							
23	3306-81380	SCREEN	1	1	† 1						
24	2810-81120	COVER	1	1							
25	3310-81130	SCREW	1	1							
26	3304-81910	GASKET KIT	1	1	† 1						
27	2810-06040	DIAPHRAGM KIT	1	1	† 1						
28	2810-81170	LOW SPEED NEEDLE	1	1							
29	1491-81160	SPRING	1	1							

† 1 Component of 2810-06030 REPAIR KIT (Optional)

Fig. 6 BAR MOUNT, CHAIN BRAKE

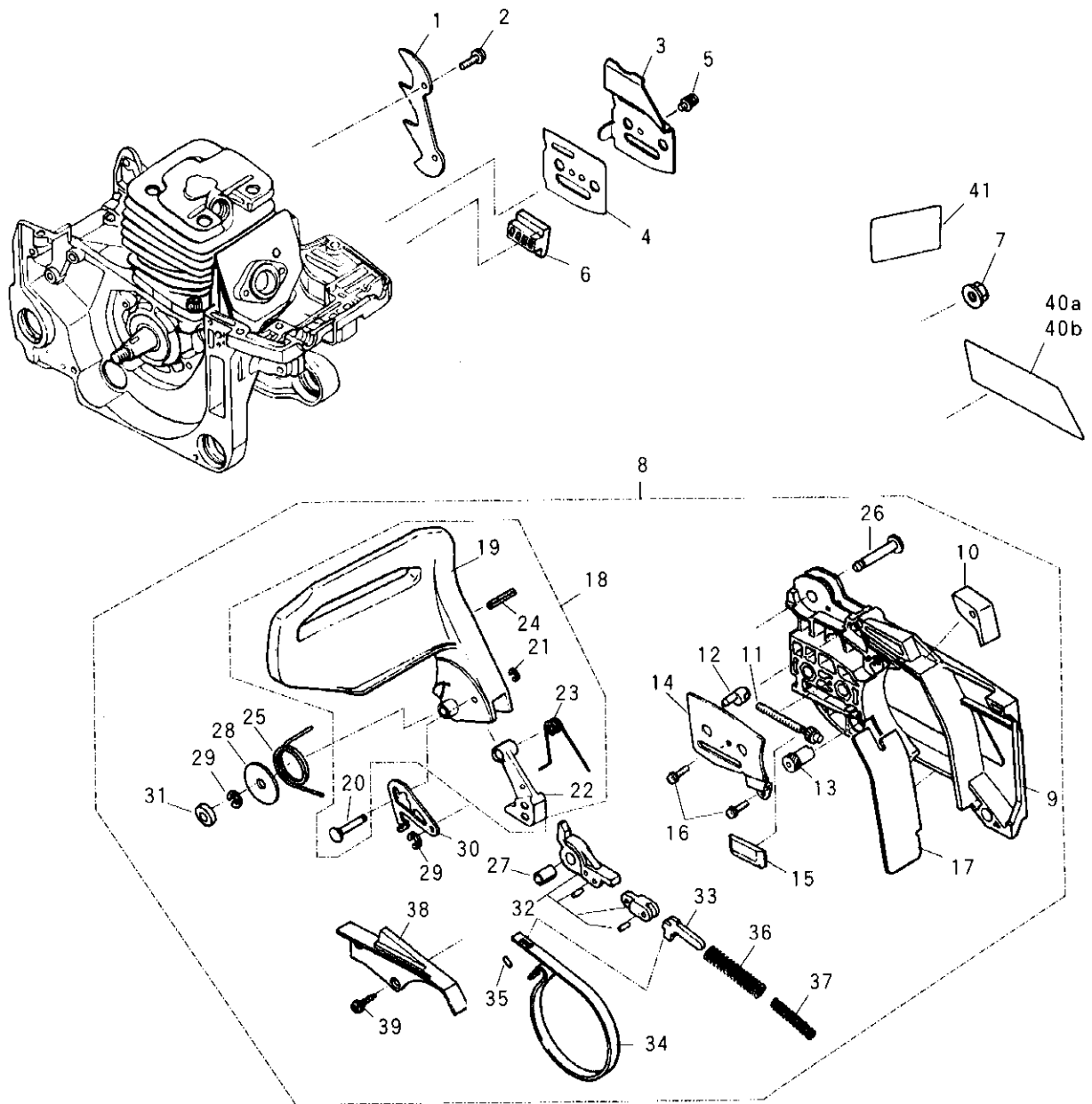

Fig. 6 BAR MOUNT, CHAIN BRAKE

Key#	PART NUMBER	DESCRIPTION	Q'TY/UNIT		NOTE
			G410	G455	
1	2670-25310	BUMPER	1	1	
2	2670-14320	SCREW	2	2	
3	2810-25420	PLATE	1	1	
4	2810-25450	PLATE	1	1	
5	2670-25430	SCREW	1	1	
6	2670-25410	GUIDE	1	1	
7	3350-53410	NUT	2	2	
8	2880-54002	CHAIN COVER ASS'Y	1	1	
9	2671-53114	COVER	1	1	
10	2880-53150	STOPPER	1	1	
11	2671-53210	SCREW	1	1	
12	2810-53221	NUT	1	1	
13	2671-53230	GEAR	1	1	
14	2671-53240	PLATE	1	1	
15	2670-25410	GUIDE	1	1	
16	2670-54630	SCREW	2	2	
17	2671-53311	PROTECTOR	1	1	
18	2880-54101	GUARD COMP.	1	1	
19	2880-54111	GUARD	1	1	
20	2670-54121	PIN	1	1	
21	0308-00030	RING	1	1	
22	2880-54130	WEIGHT	1	1	
23	2880-54140	SPRING	1	1	
24	2880-54150	PIN	1	1	
25	2670-54210	SPRING	1	1	
26	2670-54220	PIN	1	1	
27	2670-54231	SPACER	1	1	
28	3238-15230	WASHER	1	1	
29	0308-00040	RING	2	2	
30	2810-54240	PLATE	1	1	

Key#	PART NUMBER	DESCRIPTION	Q'TY/UNIT		NOTE
			G410	G455	
31	2810-54260	SPACER	1	1	
32	2670-54302	BRAKE LEVER COMP.	1	1	
33	2670-54410	ARM	1	1	
34	2670-54510	BAND	1	1	
35	3356-24140	ROLLER	1	1	
36	2670-54610	SPRING	1	1	
37	2880-54650	SPRING	1	1	
38	2670-54621	COVER	1	1	
39	2670-54630	SCREW	3	3	
40a	2820-53121	LABEL	1	—	
40b	2810-53121	LABEL	—	1	
41	2874-54990	LABEL	1	1	

Fig. 7 GUIDE BAR, SAW CHAIN, TOOLS

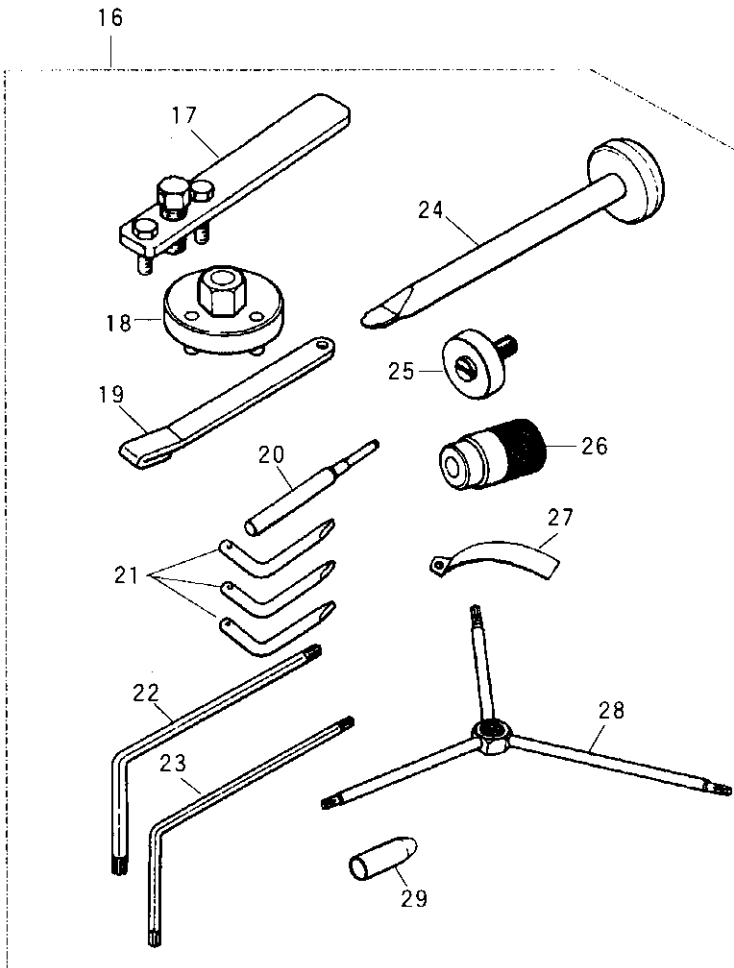
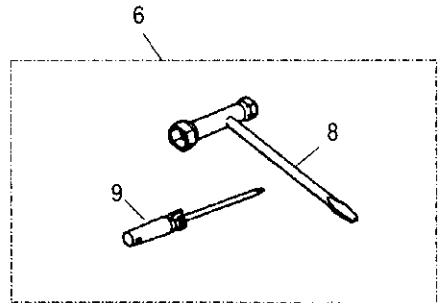
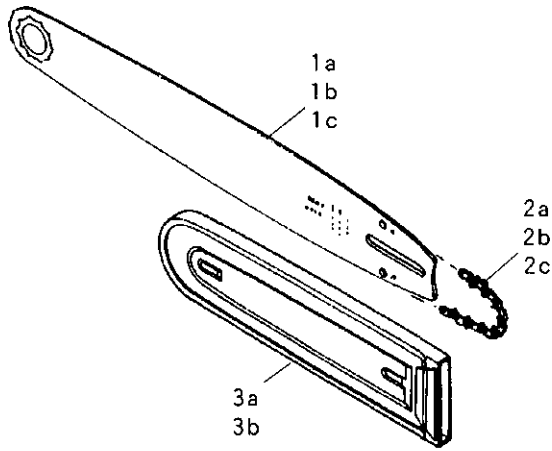

Fig. 7 GUIDE BAR, SAW CHAIN, TOOLS

Key#	PART NUMBER	DESCRIPTION	Q'TY/UNIT		NOTE
			G410	G455	
1a	3644-52112	BAR 14	1	1	† 1
1b	3645-52113	BAR 16	1	1	† 1
1c	3646-52113	BAR 18	1	1	† 1
2a	3644-52210	CHAIN 21VB-60E	1	1	† 2
2b	3645-52210	CHAIN 21VB-66E	1	1	† 3
2c	2976-52210	CHAIN 21VB-72E	1	1	† 4
3a	3310-97112	PROTECTOR	1	1	† 5
3b	3356-97110	PROTECTOR	1	1	† 6
6	2810-91000	TOOL SET	1	1	
8	3320-91140	WRENCH	1	1	
9	2670-91150	SCREWDRIVER	1	1	
16	2670-96002	TOOL SET	1	1	† 7
17	2890-96100	PULLER ASS'Y	1	1	† 7
18	2670-96210	WRENCH	1	1	† 7
19	2670-96220	STOPPER	1	1	† 7
20	3350-96230	GUIDE	1	1	† 7
21	2670-96240	WRENCH	3	3	† 7
22	2670-96310	WRENCH	1	1	† 7
23	2670-96320	WRENCH	1	1	† 7
24	2670-96510	GUIDE	1	1	† 7
25	3350-96620	GUIDE	1	1	† 7
26	2670-96660	HOLDER	1	1	† 7
27	3350-96240	GAUGE	1	1	† 7
28	2670-96410	WRENCH	1	1	† 7
29	2810-96710	GUIDE	1	1	† 7

† 1 Raminated sprocket nose type, Gauge .058 (Opt. Part)

† 2 For Bar 14 (Opt. Part)

† 3 For Bar 16 (Opt. Part)

† 4 For Bar 18 (Opt. Part)

† 5 For Bar 14 (Opt. Part)

† 6 For Bar 16 & 18 (Opt. Part)

† 7 Special tools (Opt. Part)