

# PARTS CATALOG

## 4-STROKE AIR-COOLED ENGINE

# FG300D

PRODUCT CODE	NOTE
FG300D—AS16	
BS16	

E0110-2004D

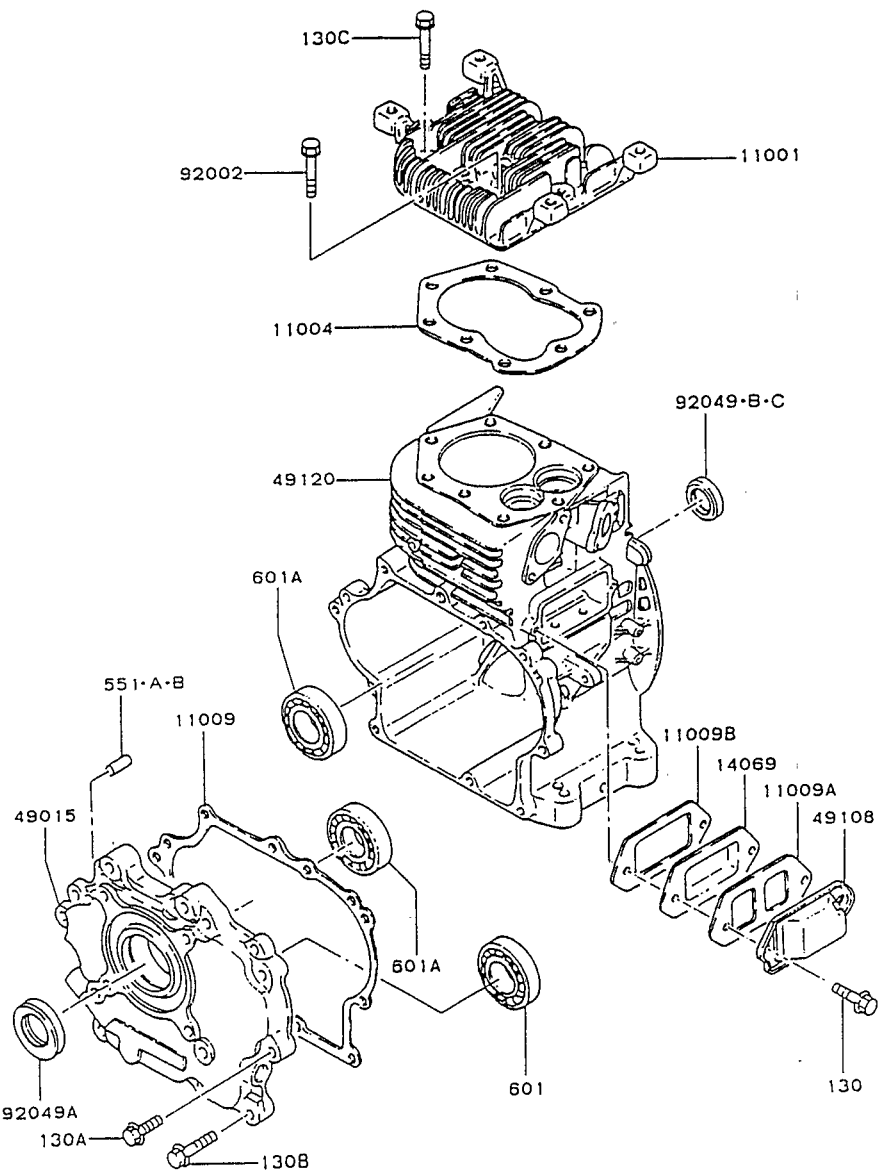

Ref. No.	Parts No.	Description	Quantity	
			A	B
11001	11001-2055	HEAD-CYLINDER	1	1
11004	11004-2055	GASKET-HEAD	1	1
11009	11009-2113	GASKET, CRANKCASE COVER	1	1
11009A	315801-1233A	GASKET	1	1
11009B	316470-1232-00	GASKET	1	1
14069	315801-1510E	BREATHER	1	1
49015	49015-6022	COVER-CRANKCASE	1	1
49108	49108-2054	COVER-VALVE CHAMBER	1	1
49120	49120-2163	CRANKCASE-COMP	1	1
92002	315801-1181A	BOLT	3	3
92049	315801-4231A	SEAL-OIL	*	
92049A	315801-4235A	SEAL-OIL	1	1
92049B	92049-2199	SEAL-OIL		1
92049C	92049-2199	SEAL-OIL	1	
130	13080612	BOLT-FLANGED	2	2
130A	13080828	BOLT-FLANGED	2	2
130B	13080835	BOLT-FLANGED	7	7
130C	130G1045	BOLT-FLANGED	5	5
551	551A0814	PIN-DOWEL		2
551A	551A0814	PIN-DOWEL	2	
551B	551A0816	PIN-DOWEL	*	
601	601A6204	BEARING-BALL	1	1
601A	601A6206	BEARING-BALL	2	2

E0130-2016A

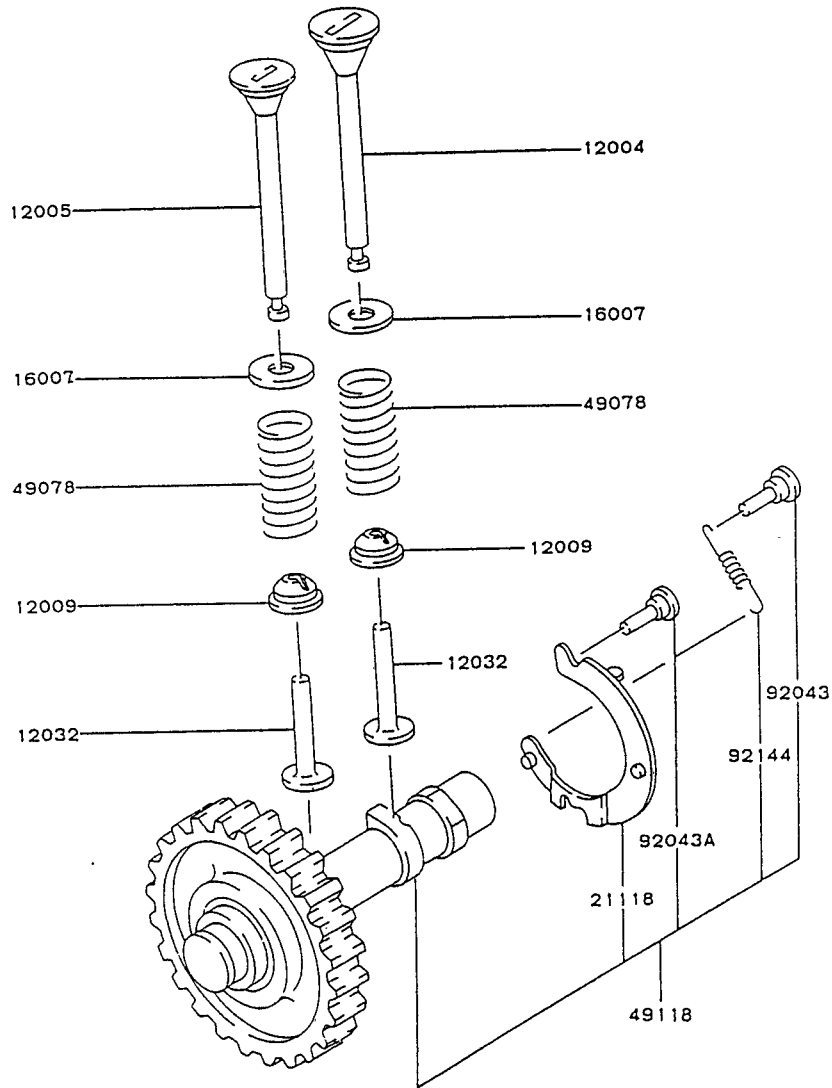

Ref. No.	Parts No.	Description	Quantity	
			A	B
12004	12004-2088	VALVE-INTAKE	1	1
12005	315801-2112A	VALVE-EXHAUST	1	1
12009	315801-2116A	RETAINER-VALVE SPRING	2	2
12032	315801-2211A	TAPPET	2	2
16007	315801-2121A	SEAT-SPRING	2	2
21118	21118-2067	DECOMPRESSOR	1	1
49078	315801-2113A	SPRING-ENGINE VALVE	2	2
49118	49118-6024	CAMSHAFT-COMP	1	1
92043	92043-2122	PIN	1	1
92043A	92043-2130	PIN	2	2
92144	92144-2049	SPRING	1	1

This catalog covers:

FG300D-  S16

B-04

This grid covers:

PISTON/C. ,NKSHAFT

E0120-2004F

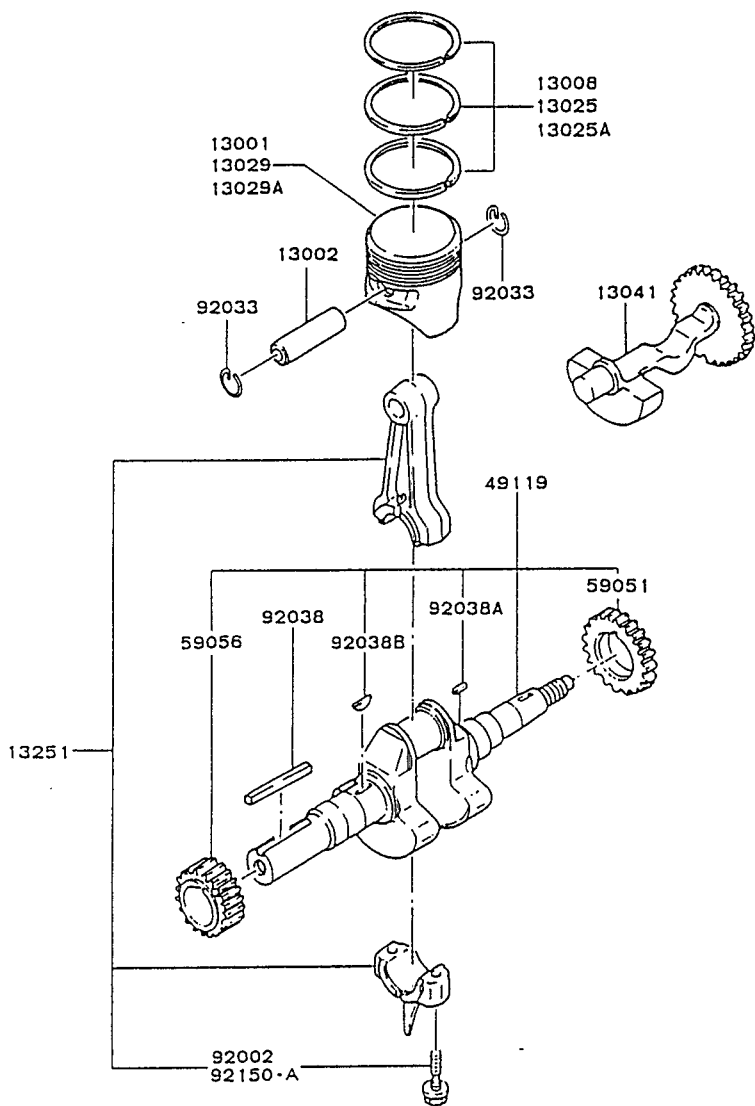

Ref. No.	Parts No.	Description	Quantity	
			A	B
13001	315801-3111F	PISTON-ENGINE	1	1
13002	13002-2068	PIN-PISTON	1	1
13008	315801-3010B	RING-SET-PISTON	1	1
13025	13025-2071	RING-SET-PISTON L.0.25	AR	AR
13025A	13025-2072	RING-SET-PISTON L.0.50	AR	AR
13029	13029-2075	PISTON-ENGINE L.0.25	AR	AR
13029A	13029-2076	PISTON-ENGINE L.0.50	AR	AR
13041	13041-2051	BALANCER	1	1
13251	13251-6028	ROD-ASSY-CONNECTING	1	1
49119	315811-3210A	CRANKSHAFT-ASSY	1	1
59051	59051-2054	GEAR-SPUR	1	1
59056	59056-2015	GEAR-HELICAL	1	1
92002	315801-3245A	BOLT	*	
92033	315801-3122A	RING-SNAP	2	2
92038	317101-3272-00	KEY	1	1
92038A	92038-2051	KEY	1	1
92038B	92038-2077	KEY	1	1
92150	92150-2193	BOLT		2
92150A	92150-2193	BOLT	2	

This catalog covers:

FG300D-  S16

B-07

This grid covers:

COOLING- EQUIPMENT

E0150-2234A

Ref. No.	Parts No.	Description	Quantity	
			A	B
49089	315821-1632B	SHROUD-ENGINE	1	1
59066	59066-2404-9H	HOUSING-FAN	*	
	(	- FG300-111965)		
59066A	59066-2513-9H	HOUSING-FAN		1
59066B	59066-2513-9H	HOUSING-FAN	1	
	(	FG300-111966 - )		
130	130B0612	BOLT-FLANGED	5	5

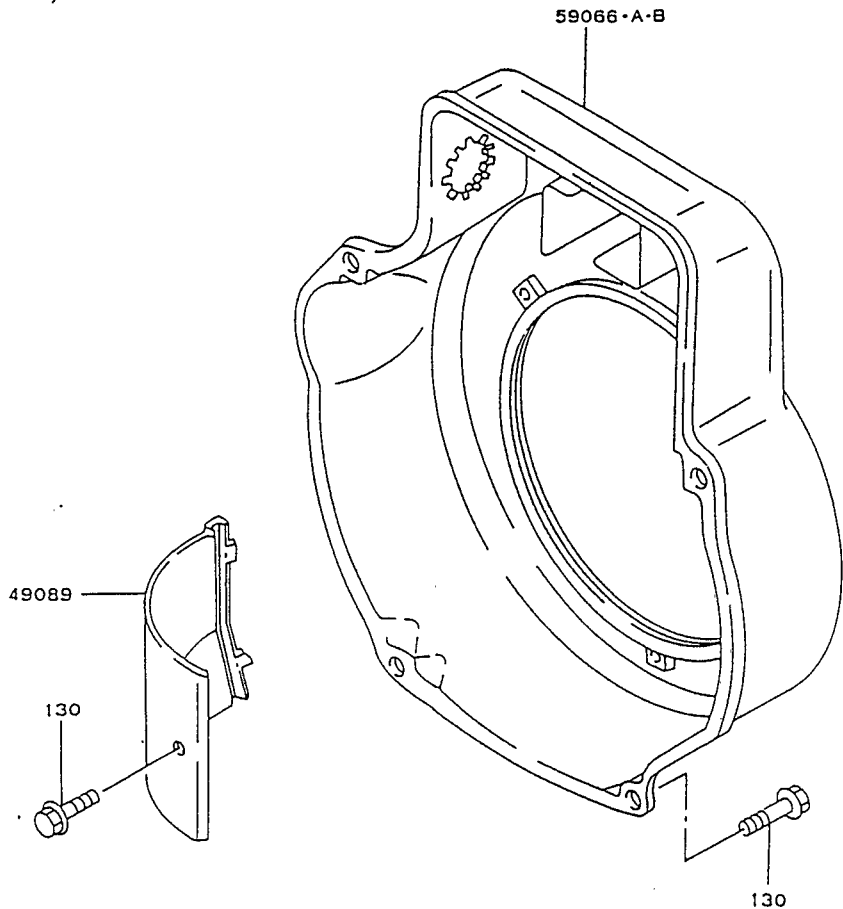

This catalog covers:

FG300D-  S16

**B-06**

This grid covers:

LUBRICAT I-EQUIPMENT

E0140-2050H

Ref. No.	Parts No.	Description	Quantity	
			A	B
11009	315470-7214A	GASKET	*	
16115	16115-2051	CAP-OIL FILLER	*	
16115A	16115-2083	CAP-OIL FILLER		1
16115B	16115-2083	CAP-OIL FILLER	1	
92055	92055-2064	RING-O	1	1
92065	92065-097	GASKET		2
92065A	92065-097	GASKET	2	
92066	92066-2101	PLUG	2	2

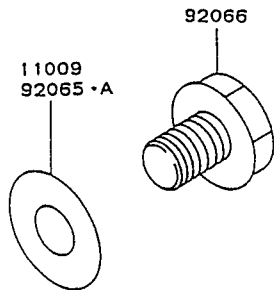
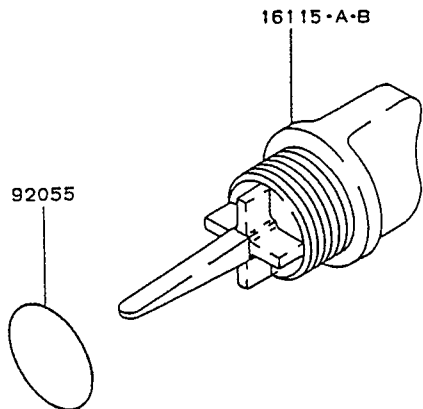

This catalog covers:

FG300D-  S16

**B-09**

This grid covers:

**CONTROL EQUIPMENT**

E0170-2311A

Quantity

Ref. No.	Parts No.	Description	Quantity	
			A	B
11043	315801-5337A	BRACKET	1	1
13236	13236-2080	LEVER-COMP	1	1
14024	14024-2067	COVER	1	1
39003	39003-2053	ARM-PIVOT	1	
	( FG300-119655 )			
39003A	39003-2070	ARM-PIVOT		1
39003B	39003-2070	ARM-PIVOT	1	
	( FG300-119656 - )			
39184	39184-2057	BRACKET-ASSY	1	1
42036	314401-5121B	SLEEVE	1	1
49046	315801-5231B	ROD-GOVERNOR	1	1
49103	315801-5211C	ARM-GOVERNOR	1	1
49110	315801-5110A	GOVERNOR-ASSY	1	1
92002	315501-5381A	BOLT	1	1
92002A	92002-2269	BOLT	1	1
92009	314405-3092A	SCREW	*	
92009A	92009-2307	SCREW		3
92009B	92009-2307	SCREW	3	
92015	314401-5385A	NUT	1	1
92015A	92015-1193	NUT	1	1
92022	314401-5135A	WASHER	1	1
92022A	314401-5383A	WASHER	1	1
92037	92037-2020	CLAMP	1	1
92081	314401-5388A	SPRING	1	1
92081A	315801-5232B	SPRING	1	1
92081B	315801-5314A	SPRING	1	1
92081C	315801-5317B	SPRING	1	1
92144	92144-2004	SPRING	2	2
92200	92200-2029	WASHER, 6.5X11.5X2.0		1
92200A	92200-2029	WASHER, 6.5X11.5X2.0	1	
	( FG300-119655 - )			
130	130B0616	BOLT-FLANGED	2	2
214	214B0515	SCREW-PAN++	1	1
214A	214B0518	SCREW-PAN++	1	1
410	410B0600	W-PLAIN-S	2	
	( FG300-119655 )			
411	411B0500	WASHER-PLAIN	1	1
554	554A0600	PIN-SNAP	1	1

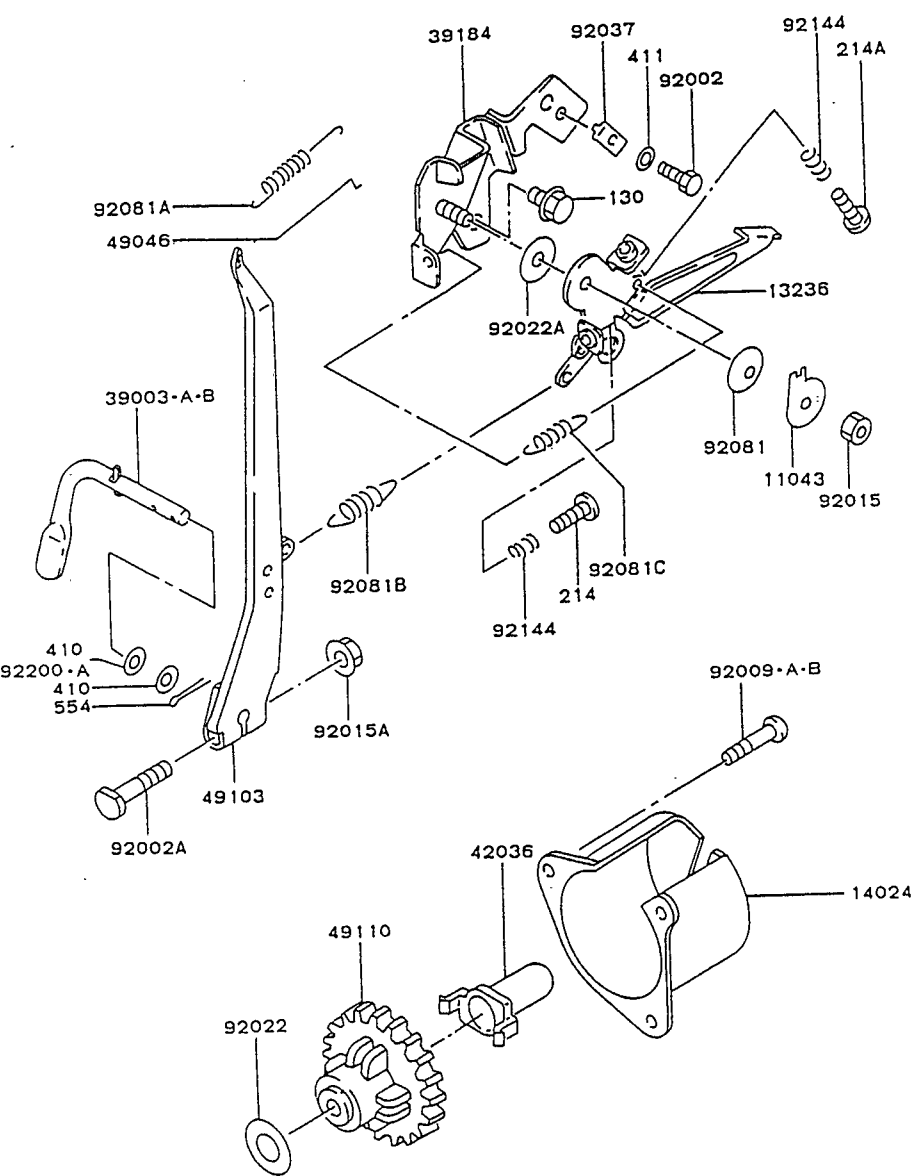

This catalog covers:

FG300D-  S16

**B-08**

This grid covers:

**ELECTRIC EQUIPMENT**

E0160-2251B

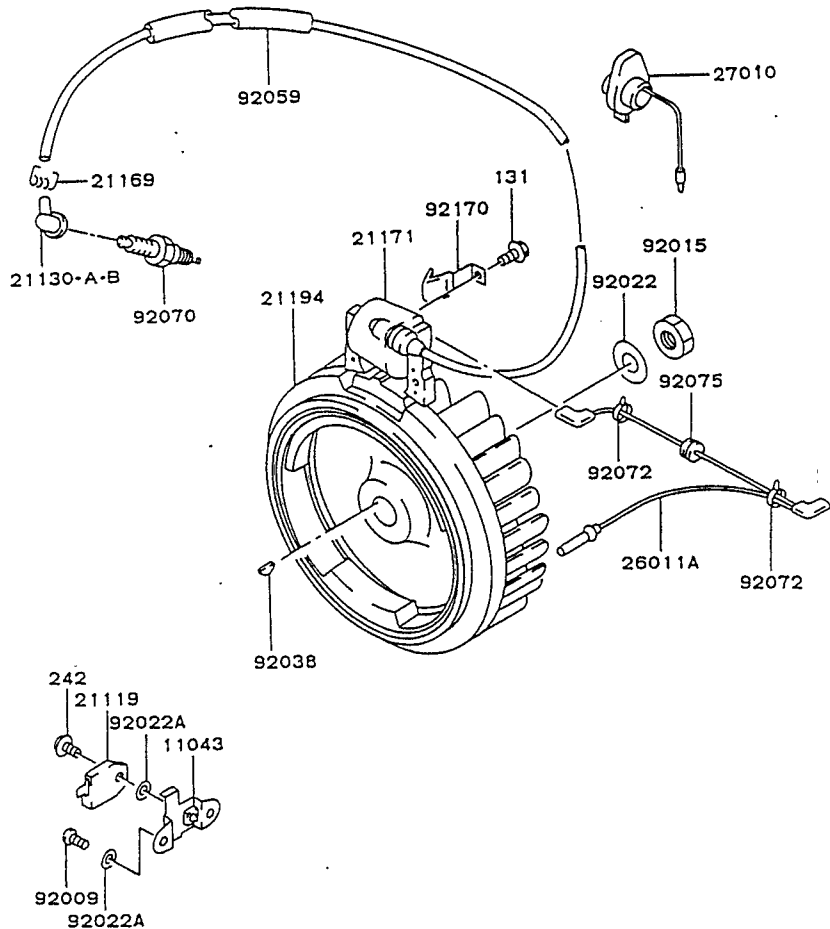

Ref. No.	Parts No.	Description	Quantity	
			A	B
11043	314601-8137A	BRACKET	1	1
21119	21119-2111	IGNITER	1	1
21130	21130-2066	CAP-SPARK PLUG		1
21130A	21130-2066	CAP-SPARK PLUG	1	
21130B	317270-8418B	CAP-SPARK PLUG	*	
21169	21169-2057	TERMINAL	1	1
21171	21171-2148	COIL-ASSY-IGNITION	1	1
21194	21194-2177	FLYWHEEL-COMP	1	1
26011	26011-2232	WIRE-LEAD	1	1
27010	315801-8511A	SWITCH	1	1
92009	315601-6732A	SCREW	2	2
92015	92015-2157	NUT(M14-R)	1	1
92022	314401-3482A	WASHER	1	1
92022A	315801-6625A	WASHER	3	3
92038	92038-2077	KEY	1	1
92059	31362A-8168-00	TUBE	1	1
92070	92070-2052	PLUG-SPARK, BP4HS(NGK)	1	1
92072	316691-8577A	BAND	2	2
92075	92075-2095	DAMPER	1	1
92170	92170-2004	CLAMP	1	1
131	131B0520	BOLT-FLANGED	2	2
242	242B0410	SCREW-PAN-WSP+-	1	1



E0190-2306A

Ref. No.	Parts No.	Description	Quantity	
			A	B
11009	11009-2128	GASKET, MUFFLER	1	1
11009A	11009-2478	GASKET	1	1
11010	11010-2355-9H	FILTER-ASSY-AIR	1	1
11011	11011-2210-9H	CASE-AIR FILTER	1	1
11012	11012-2210	CAP, AIR FILTER	1	1
11013	11013-2103	ELEMENT-AIR FILTER	1	1
32033	314401-1341A	PIPE	1	1
49064	49064-2066	FILTER-AIR	1	1
49070	49070-2142-9Y	MUFFLER-COMP	1	
49070A	49070-2519-9Y	MUFFLER-COMP		1
49106	49106-2281-9X	COVER-MUFFLER	1	1
49106A	49106-2321-9X	COVER-MUFFLER	1	1
92009	314405-3092A	SCREW	*	
92009A	92009-2307	SCREW		3
92009B	92009-2307	SCREW	3	
92015	92015-1193	NUT	2	2
110	110R0610	BOLT	5	5
171	171G0818	BOLT-STUD	2	2
183	183B0814	BOLT-UPSET-WS-SMALL	1	1
317	317R0800	NUT-HEX-SMALL	2	2
410	410B0600	W-PLAIN-S	5	5
410A	410B0800	W-PLAIN-S	1	1
461	461F0600	WASHER-SPRING	5	5
461A	461F0800	WASHER-SPRING	2	2
702	702A071000	TUBE-RUBBER ,L=127MM	1	1

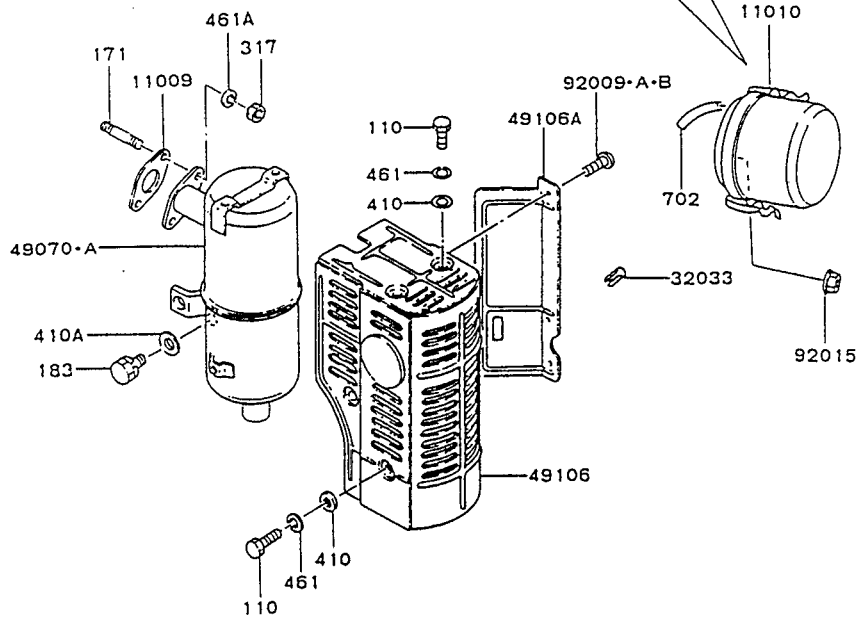
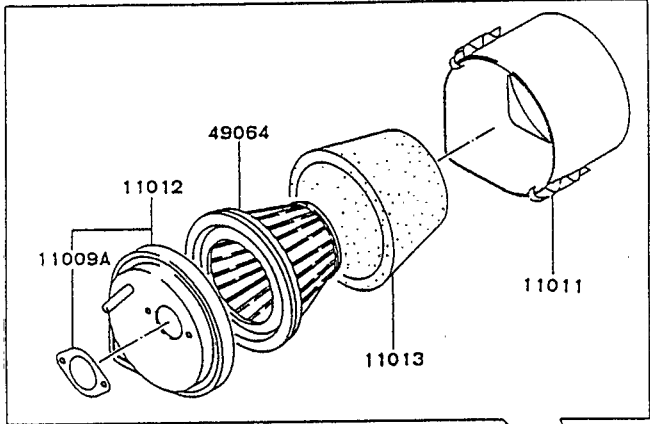

This catalog covers:

FG300D-  S16

**B-10**

This grid covers:

CARBURETOR (

E0180-2091A

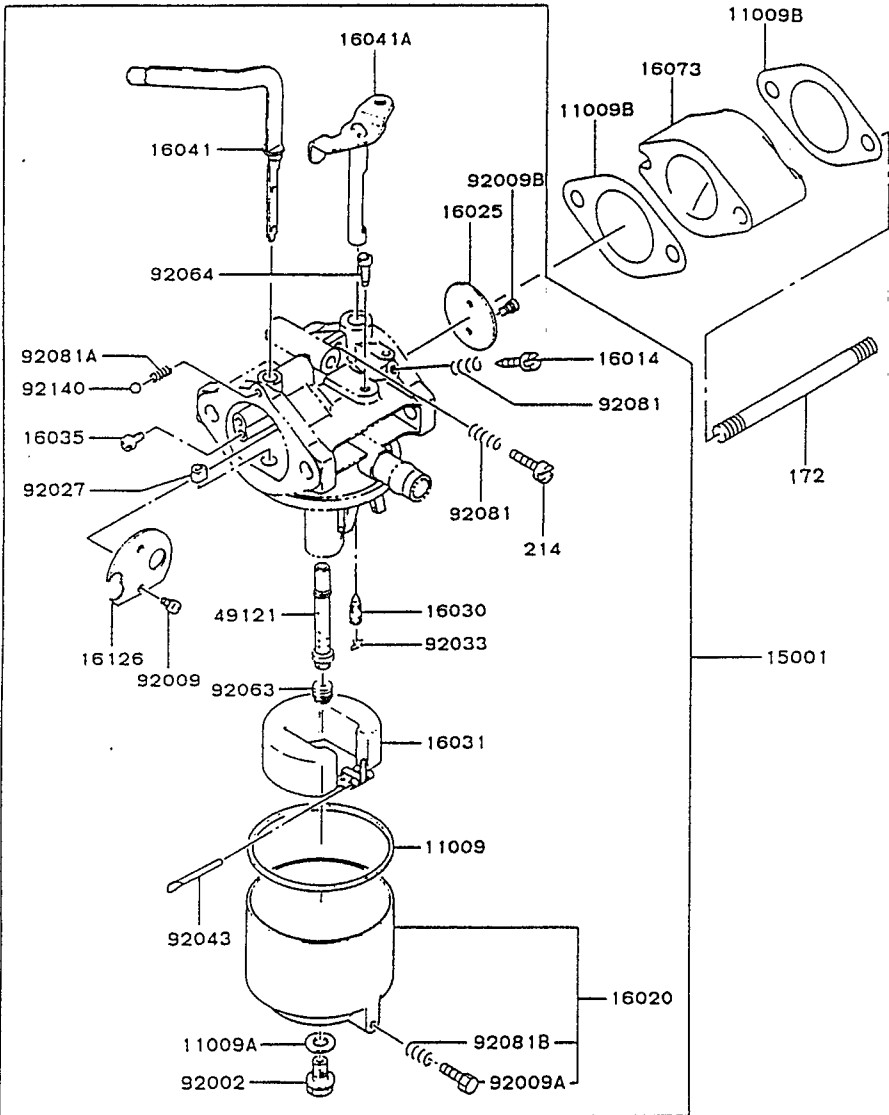

Ref. No.	Parts No.	Description	Quantity	
			A	B
11009	313650-6128-00	GASKET	1	1
11009A	314499-6159A	GASKET	1	1
11009B	315801-6184A	GASKET	2	2
15001	15001-2792	CARBURETOR ASSY	1	1
16014	313650-6114-00	SCREW-PILOT AIR	1	1
16020	16020-2005	CHAMBER-FLOAT	1	1
16025	16025-2134	VALVE-THROTTLE, #130	1	1
16030	16030-2075	VALVE-FLOAT	1	1
16031	16031-2065	FLOAT	1	1
16035	16035-2061	JET-AIR, #1.2	1	1
16041	16041-2053	SHAFT-CARBURETOR, CHOKE	1	1
16041A	315823-6139A	SHAFT-CARBURETOR	1	1
16073	16073-2092	INSULATOR	1	1
16126	315801-6102A	VALVE	1	1
49121	49121-2110	NOZZLE, MAIN #15A	1	1
92002	92002-2319	BOLT	1	1
92009	314572-6137A	SCREW	2	2
92009A	315470-6133A	SCREW	1	1
92009B	316550-6137A	SCREW	2	2
92027	314598-6138A	COLLAR	1	1
92033	314595-6134A	RING-SNAP	1	1
92043	314499-6127A	PIN	1	1
92063	92063-2152	JET-MAIN, #87.5	1	1
92064	313401-6112-00	JET-PILOT, #40	1	1
92081	312750-6116-00	SPRING	2	2
92081A	313122-6103-00	SPRING	1	1
92081B	313122-6116-00	SPRING	1	1
92140	313122-6104-00	BALL	1	1
172	172G0692	BOLT-STUD	2	2
214	214B0414	SCREW-PAN+-	1	1

This catalog covers:

FG300D-  S16

B-13

This grid covers:

STARTER

E0210-2018A

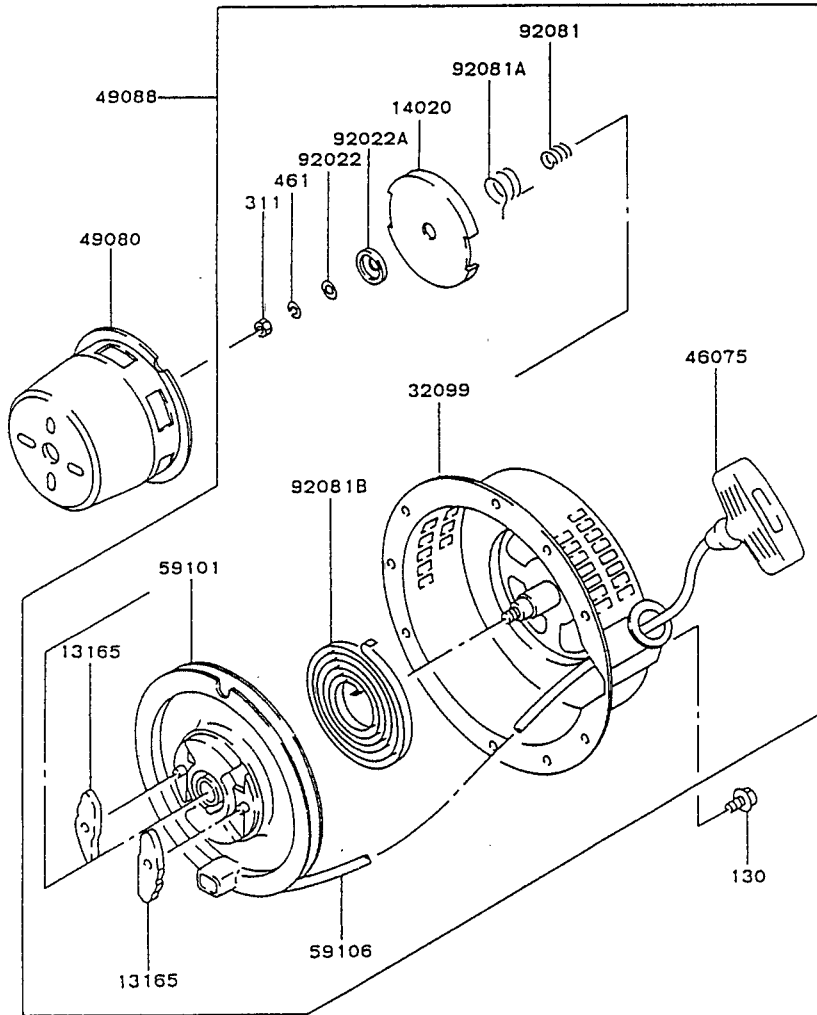

Ref. No.	Parts No.	Description	Quantity	
			A	B
13165	316420-3445B	PAWL	2	2
14020	316420-3449B	RETAINER	1	1
32099	315811-3437A	CASE	1	1
46075	312211-3454-00	GRIP	1	1
49080	49080-2111	PULLEY-STARTING	1	1
49088	49088-2085-9H	STARTER-RECOIL	1	1
59101	316451-3441A	REEL	1	1
59106	316420-3453A	ROPE, 6X1620	1	1
92022	316420-3442B	WASHER	1	1
92022A	316451-3456A	WASHER	1	1
92081	316420-3446A	SPRING	1	1
92081A	316420-3448A	SPRING	1	1
92081B	318863-3452-00	SPRING	1	1
130	130B0612	BOLT-FLANGED	3	3
311	311B0600	NUT-HEX	1	1
461	461F0600	WASHER-SPRING	1	1

E0200-2004A

Ref. No.	Parts No.	Description	Quantity	
			A	B
11009	315801-6518A	GASKET	1	1
11009A	315801-6643B	GASKET	1	1
14043	315801-6519A	FILTER	1	1
32052	32052-2053-9H	BRACKET-TANK	1	1
49019	315801-6661F	FILTER-FUEL	1	1
49091	49091-2053	WASHER-SEAL	2	2
51001	51001-2053-9H	TANK-COMP-FUEL	1	1
51023	51023-2096	TAP-ASSY	1	1
51036	51036-2062	CUP, FUEL TAP	1	1
51048	51048-2055	CAP-ASSY-TANK	1	1
52005	52005-2072	GAUGE, FUEL	1	1
92002	92002-2055	BOLT	4	4
92009	314401-6732A	SCREW	2	2
92009A	315801-6577A	SCREW	4	4
92009B	92009-1123	SCREW	2	2
92037	313679-6812-00	CLAMP	2	2
92055	315801-6512A	RING-O	1	1
92059	315802-6811A	TUBE	1	1
92075	315801-6723A	DAMPER	2	2
92081	315801-6644A	SPRING	1	1
187	187B0614	BOLT-UPSET-WSP	4	4

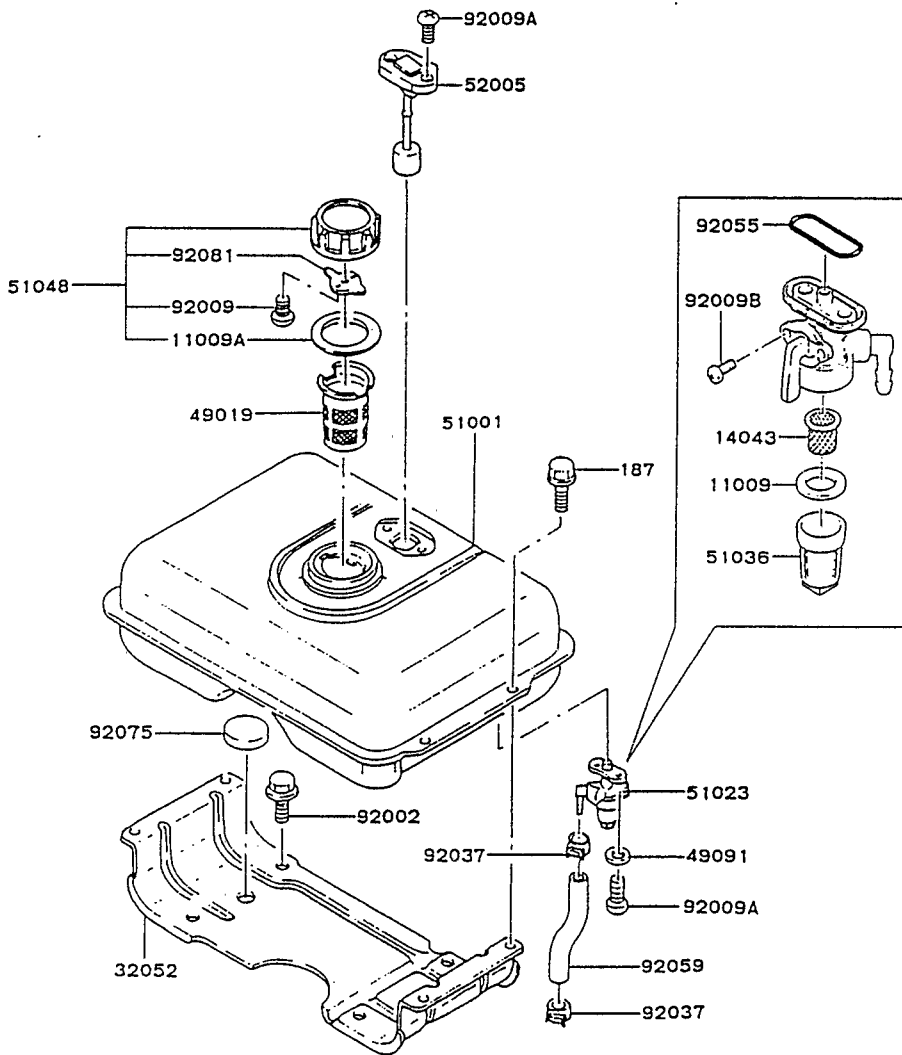

Parts No.	Grid No.	Parts No.	Grid No.	Parts No.	Grid No.	Parts No.	Grid No.	Parts No.	Grid No.
110R0610	B-11	313122-6116-00	B-10	315811-3210A	B-04	59066-2404-9H	B-07		
11001-2055	B-03	313401-6112-00	B-10	315811-3437A	B-13	59066-2513-9H	B-07		
11004-2055	B-03	31362A-8168-00	B-08	315821-1632B	B-07	59066-2513-9H	B-07		
11009-2113	B-03	313650-6114-00	B-10	315823-6139A	B-10	601A6204	B-03		
11009-2128	B-11	313650-6128-00	B-10	316420-3442B	B-13	601A6206	B-03		
11009-2478	B-11	313679-6812-00	B-12	316420-3445B	B-13	702A071000	B-11		
11010-2355-9H	B-11	314401-1341A	B-11	316420-3446A	B-13	92002-2055	B-12		
11011-2210-9H	B-11	314401-3482A	B-08	316420-3448A	B-13	92002-2269	B-09		
11012-2210	B-11	314401-5121B	B-09	316420-3449B	B-13	92002-2319	B-10		
11013-2103	B-11	314401-5135A	B-09	316420-3453A	B-13	92009-1123	B-12		
12004-2088	B-05	314401-5383A	B-09	316451-3441A	B-13	92009-2307	B-09		
130B0612	B-03	314401-5385A	B-09	316451-3456A	B-13	92009-2307	B-09		
130B0612	B-07	314401-5388A	B-09	316470-1232-00	B-03	92009-2307	B-11		
130B0612	B-13	314401-6732A	B-12	316550-6137A	B-10	92009-2307	B-11		
130B0616	B-09	314405-3092A	B-09	316691-8577A	B-08	92015-1193	B-09		
130B0828	B-03	314405-3092A	B-11	317R0800	B-11	92015-1193	B-11		
130B0835	B-03	314499-6127A	B-10	317101-3272-00	B-04	92015-2157	B-08		
130G1045	B-03	314499-6159A	B-10	317270-8418B	B-08	92037-2020	B-09		
13002-2068	B-04	314572-6137A	B-10	318863-3452-00	B-13	92038-2051	B-04		
13025-2071	B-04	314595-6134A	B-10	32052-2053-9H	B-12	92038-2077	B-04		
13025-2072	B-04	314598-6138A	B-10	39003-2053	B-09	92038-2077	B-08		
13029-2075	B-04	314601-8137A	B-08	39003-2070	B-09	92043-2122	B-05		
13029-2076	B-04	315470-6133A	B-10	39003-2070	B-09	92043-2130	B-05		
13041-2051	B-04	315470-7214A	B-06	39184-2057	B-09	92049-2199	B-03		
131B0520	B-08	315501-5381A	B-09	410B0600	B-09	92049-2199	B-03		
13236-2080	B-09	315601-6732A	B-08	410B0600	B-11	92055-2064	B-06		
13251-6028	B-04	315801-1181A	B-03	410B0800	B-11	92063-2152	B-10		
14024-2067	B-09	315801-1233A	B-03	411B0500	B-09	92065-097	B-06		
15001-2792	B-10	315801-1510E	B-03	461F0600	B-11	92065-097	B-06		
16020-2005	B-10	315801-2112A	B-05	461F0600	B-13	92066-2101	B-06		
16025-2134	B-10	315801-2113A	B-05	461F0800	B-11	92070-2052	B-08		
16030-2075	B-10	315801-2116A	B-05	49015-6022	B-03	92075-2095	B-08		
16031-2065	B-10	315801-2121A	B-05	49064-2066	B-11	92144-2004	B-09		
16035-2061	B-10	315801-2211A	B-05	49070-2142-9Y	B-11	92144-2049	B-05		
16041-2053	B-10	315801-3010B	B-04	49070-2519-9Y	B-11	92150-2193	B-04		
16073-2092	B-10	315801-3111F	B-04	49080-2111	B-13	92150-2193	B-04		
16115-2051	B-06	315801-3122A	B-04	49088-2085-9H	B-13	92170-2004	B-08		
16115-2083	B-06	315801-3245A	B-04	49091-2053	B-12	92200-2029	B-09		
16115-2083	B-06	315801-4231A	B-03	49106-2281-9X	B-11	92200-2029	B-09		
171G0818	B-11	315801-4235A	B-03	49106-2321-9X	B-11				
172G0692	B-10	315801-5110A	B-09	49108-2054	B-03				
183B0814	B-11	315801-5211C	B-09	49118-6024	B-05				
187B0614	B-12	315801-5231B	B-09	49120-2163	B-03				
21118-2067	B-05	315801-5232B	B-09	49121-2110	B-10				
21119-2111	B-08	315801-5314A	B-09	51001-2053-9H	B-12				
21130-2066	B-08	315801-5317B	B-09	51023-2096	B-12				
21130-2066	B-08	315801-5337A	B-09	51036-2062	B-12				
21169-2057	B-08	315801-6102A	B-10	51048-2055	B-12				
21171-2148	B-08	315801-6184A	B-10	52005-2072	B-12				
21194-2177	B-08	315801-6512A	B-12	551A0814	B-03				
214B0414	B-10	315801-6518A	B-12	551A0814	B-03				
214B0515	B-09	315801-6519A	B-12	551A0816	B-03				
214B0518	B-09	315801-6577A	B-12	554A0600	B-09				
242B0410	B-08	315801-6625A	B-08	56030-2179	C-03				
26011-2232	B-08	315801-6643B	B-12	56031-2307	C-03				
311B0600	B-13	315801-6644A	B-12	56031-2308	C-03				
312211-3454-00	B-13	315801-6661F	B-12	56038-2489	C-03				
312750-6116-00	B-10	315801-6723A	B-12	56040-2188	C-03				
313122-6103-00	B-10	315801-8511A	B-08	59051-2054	B-04				
313122-6104-00	B-10	315802-6811A	B-12	59056-2015	B-04				

F0290-2321A

Ref. No.	Parts No.	Description	Quantity	
			A	B
56030	56030-2179	LABEL	1	1
56031	56031-2307	LABEL-MANUAL	1	1
56031A	56031-2308	LABEL-MANUAL	1	1
56038	56038-2489	LABEL-BRAND	1	1
56040	56040-2188	LABEL-WARNING	1	1

56030

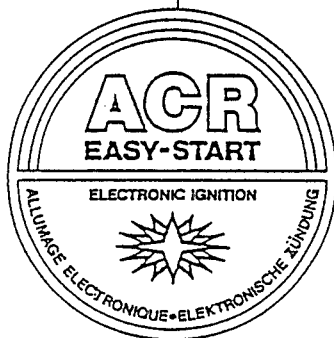

56031A

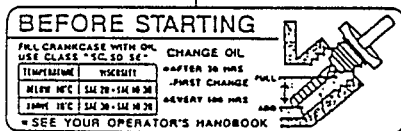

56031

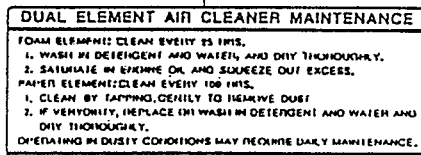

56038

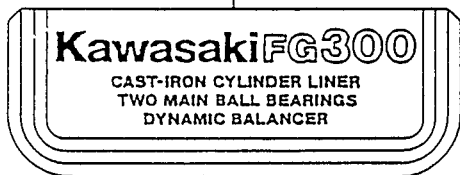

56040

