

94  
CHASSIS - MANICO - COMANDI  
DECK - HANDLE - CONTROLS  
CHASSIS - MANCHERON - COMMANDES  
GEHÄUSE - HOLM - BETÄTIGUNGEN

Mod. 1994

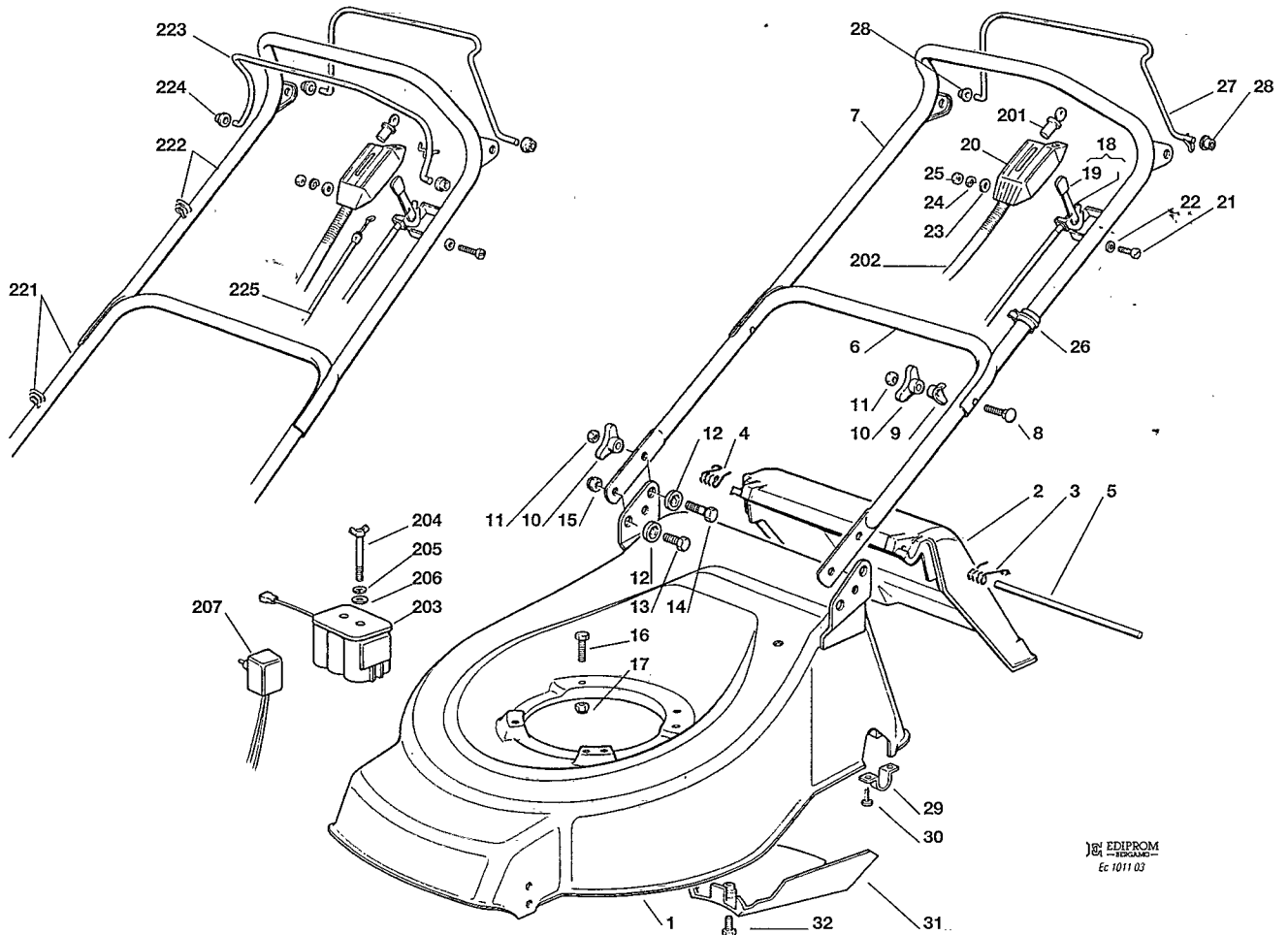

EDIPROM  
Ecl 1011 03

Pos. Nr.	Codice Code Kodex	Descrizione	Description	Description	Beschreibung	Q.tà Q.ty-Q.tè Menge
1	81001341/0	CHASSIS ROSSO TD 484 TR	RED DECK TD 484 TR	CHASSIS ROUGE TD 484 TR	ROT GEHÄUSE TD 484 TR	1
-	81001342/0	CHASSIS ROSSO TD 484 TR-E	RED DECK TD 484 TR-E	CHASSIS ROUGE TD 484 TR-E	ROT GEHÄUSE TD 484 TR-E	1
2	22600046/0	PARASASSI	STONE-GUARD	PARE-PIERRES	PRALLBLECH	1
3	22450420/1	MOLLA SINISTRA	LEFT SPRING	RESSORT GAUCHE	LINK FEDER	1
4	22450410/1	MOLLA DESTRA	RIGHT SPRING	RESSORT DROITE	RECHTE FEDER	1
5	22517906/0	PERNO	PIN	PIVOT	BOLZEN	1
6	81006512/0	PARTE INFERIORE MANICO	LOWER HANDLE	PARTIE INF. MANCHERON	HOLMUNTERTEIL	1
7	81006971/0	PARTE SUPERIORE MANICO	UPPER HANDLE	PARTIE SUP. MANCHERON	HOLMOBERTEIL	1
8	12819201/0	VITE	SCREW	VIS	SCHRAUBE	2
9	22680006/1	RONDELLA	WASHER	RONDELLE	SCHLEIBE	2
16	22399900/0	MANOPOLINA	KNOB	POIGNÉE	GRIFT	4
11	12293200/0	DADO	NUT	ECROU	MUTTER	4
12	22041955/0	BUSSOLA	BUSH	DOUILLE	BUCHSE	4
13	12792610/0	VITE	SCREW	VIS	SCHRAUBE	2
14	12793700/0	VITE	SCREW	VIS	SCHRAUBE	2
15	12155000/0	DADO	NUT	ECROU	MUTTER	2
16	12793700/0	VITE M8 x 30	SCREW M8 x 30	VIS M8 x 30	SCHRAUBE M8 x 30	3/2
-	12793900/0	VITE M8 x 60	SCREW M8 x 60	VIS M8 x 60	SCHRAUBE M8 x 60	0/1
17	12293201/0	DADO	NUT	ECROU	MUTTER	3/2
-	12155000/0	DADO	NUT	ECROU	MUTTER	0/1
18	81007048/0	ASSIEME ACCELERATORE	TROTTLE UNIT ASS.Y	ENS. ACCELERATEUR	BESCHLEUNIGER	1
19	22394640/3	MANOPOLINA	KNOB	POIGNEE	GRIFT	1
20	22120142/0	CRUSCOTTO TR	DASH BOARD TR	CONSOLE TR	KONSOLE TR	1
-	22120143/0	CRUSCOTTO TR-E	DASH BOARD TR-E	CONSOLE TR-E	KONSOLE TR-E	1
21	12791400/0	VITE	SCREW	VIS	SCHRAUBE	2

Pos. Nr.	Codice Code Kodex	Descrizione	Description	Description	Beschreibung	Q.tà Q.ty-Q.tè Menge
↓						
22	12521330/0	RONDELLA	WASHER	RONDELLE	SCHEIBE	2
23	12523040/0	RONDELLA	WASHER	RONDELLE	SCHEIBE	2
24	12582100/0	GROWER	GROWER	GROWER	FEDERRING	2
25	12292100/0	DADO	NUT	ECROU	MUTTER	2
26	22192000/1	FASCETTA ANCORAGGIO	ANCHOR CLAMP	COLLIER ENCRAGE	BOWDENZUGHATER	2
27	81003288/0	LEVA TRAZIONE	DRIVING LEVER	LEVIER TRACTION	ANTRIEBHEBEL	1
28	22041965/0	BOCCOLA	BUSH	DOUILLE	BUCHSE	2
29	22545152/0	PIASTRINA	PLATE	PLAQUETTE	PLATTE	2
30	12731350/0	VITE	SCREW	VIS	SCHRAUBE	4
31	22060192/0	CARTER	DECK	CHASSIS	CHASSIS	1
32	12727791/0	VITE	SCREW	VIS	SCHRAUBE	1
		<b>Varianti per avviamento elettrico</b>	<b>Parts for electric start</b>	<b>Composants pour démarrage électrique</b>	<b>Elektrostart Bestandteile</b>	
201*	18450050/0	INTERRUTTORE	SWITCH	INTERRUPTEUR	SCHALTER	1
202*	18204190/1	ASSIEME CABLAGGIO	CABLES UNIT	ENS. CABLAGE	KABEL	1
203*	18120050/0	BATTERIA 12V - 2,5 AH	BATTERY 12V - 2,5 AH	BATTERIE 12V - 2,5 AH	BATTERIE 12V - 2,5 AH	1
204	22517855/0	PERNO	PIN	PIVOT	BOLZEN	2
205	12523000/0	RONDELLA	WASHER	RONDELLE	SCHEIBE	2
206	12540020/0	RONDELLA	WASHER	RONDELLE	SCHEIBE	2
207*	18204110/0	CARICA BATTERIA	BATTERY CHARGER	CHARGEUR DE BATTERIE	LADGERAET	1
		<b>Variante per freno motore e avviamento sul manico</b>	<b>Variants for engine brake and starting on handle</b>	<b>Variations pour frein-moteur et démarrage sur mancheron</b>	<b>Änderungen für Motorbremse und Anlassen auf Holm</b>	
221	81006514/0	PARTE INFERIORE MANICO	LOWER HANDLE	PARTIE INF. MANCHERON	UNTERHOLM	1
222	81006969/0	PARTE SUPERIORE MANICO	UPPER HANDLE	PARTIE SUP. MANCHERON	OBERHOLM	1
231	81003289/0	LEVA FRENO MOTORE	BRAKE LEVER	LEVIER FREIN MOTEUR	MOTORBREMSEHEBEL	1
232	22041966/0	BOCCOLA	BUSH	DOUILLE	HUELSE	2
233	81000621/0	CAVO FRENO MOTORE (Sprint 375)	THREAD MOTOR BRAKE (Sprint 375)	CABLE FREIN MOTEUR (Sprint 375)	MOTORBREMSEKABEL (Sprint 375)	1
-	81001106/1	CAVO FRENO MOTORE (Quantum XM)	THREAD MOTOR BRAKE (Quantum XM)	CABLE FREIN MOTEUR (Quantum XM)	MOTORBREMSEKABEL (Quantum XM)	1
-	81001107/0	CAVO FRENO MOTORE (Tecumseh)	THREAD MOTOR BRAKE (Tecumseh)	CABLE FREIN MOTEUR (Tecumseh)	MOTORBREMSEKABEL (Tecumseh)	1

**RUOTE E REGOLAZIONE  
WHEELS AND HEIGHT ADJUSTING  
ROUES ET REGLAGE HAUTEUR DE COUPE  
RAEDER UND SCHNITTVERSTELLUNG**

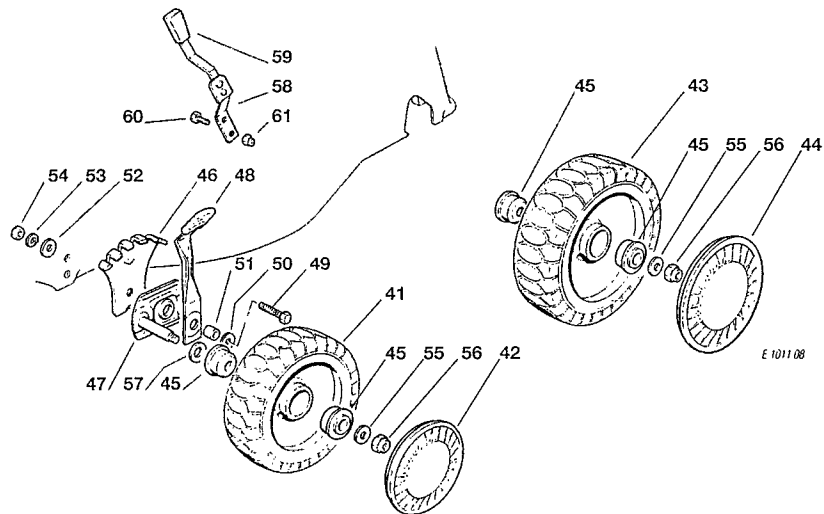

41	81007317/0	RUOTA SCOLPITA Ø 170	KNOBBLY WHEEL Ø 170	ROUE SCULPTEE Ø 170	RAD M. STOLLENPR. Ø 170	2
42	22110282/0	COPRIMOZZO BIANCO	WHITE HUB CAP	COUVRE-MOYEU BLANCHE	WEISSE RADKAPPE	2
43	81007318/0	RUOTA SCOLPITA Ø 210	KNOBBLY WHEEL Ø 210	ROUE SCULPTEE Ø 210	RAD M. STOLLENPR. Ø 210	2
44	22110281/0	COPRIMOZZO BIANCO	WHITE HUB CAP	COUVRE-MOYEU BLANCHE	WEISSE RADKAPPE	2
45	22122200/0	CUSCINETTO	BEARING	ROULEMENT	KIGELLAGER	8
46	22735547/0	SETTORE REGOLAZIONE	ADJUSTERS SECTOR	SECTEUR REGLAGE	VERSTELLUNGSSEKTOR	2
47	81005082/0	SUPPORTO RUOTA	WHEEL SUPPORT	SUPPORT ROUE	RADHALTER	2
48	81003285/0	LEVA REGOLAZIONE	ADJUSTMENT LEVER	LEVIER REGLAGE	VERSTELLUNGHEBEL	2
↓						

Dovendo sostituire in garanzia le parti contrassegnate con \* rivolgersi al Costruttore del motore

If you have to change the pieces indicated with \* on warranty you adress to after sales service of Engine Manufacturer

Si vous devez substituer les pièces indiquées avec \* sous garantie vous devez vous adresser au service après ventes de la Mainson Constructrice du moteur

Bitte wenden sie sich bei Garantiereparaturen der mit \* gekennzeichneten Teile an die Kundenienststelle des Motorhersteller

Pos. Nr.	Codice Code Kodex	Descrizione	Description	Description	Beschreibung	Q.tà Q.ty-Q.tè Menge
49	12793701/0	VITE	SCREW	VIS	SCHRAUDE	2
50	12521350/0	RONDELLA	WASHER	RONDELLE	SCHEIBE	2
51	22171001/0	DISTANZIALE	SPACER	ENTRETOISE	DISTANZRING	2
52	12523070/0	RONDELLA	WASHER	RONDELLE	SCHEIBE	2
53	12583500/0	GROWER	GROWER	GROWER	FEDERRING	2
54	12293200/0	DADO	NUT	ECROU	MUTTER	2
55	12521350/0	RONDELLA	WASHER	RONDELLE	SCHEIBE	4
56	12155000/0	DADO	NUT	ECROU	MUTTER	4
57	12530150/0	RONDELLA ELASTICA	ELASTIC WASHER	RONDELLE ELASTIQUE	ELASTISCHE SCHEIBE	2
58	81003279/1	LEVA REGOLAZIONE	ADJUSTMENT LEVER	LEVIER REGLAGE	VERSTELLUNG HEBEL	1
59	22397000/0	MANOPOLA	KNOB	POIGNEE	GRIFF	1
60	12789000/0	VITE	SCREW	VIS	SCHRAUBE	2
61	12154330/0	DADO	NUT	ECROU	MUTTER	2

**Varianti  
per ruote rigate**

**Changes  
for grooved wheels**

**Changements  
pour roues rainurées**

**Änderungen  
für Räder mit Längsprofile**

41	81007311/0	RUOTA RIGATA Ø 170	GROOVED WHEEL Ø 170	ROUE RAINUREE Ø 170	RAD M. LÄNGSPROFIL Ø 170	2
42	22110252/0	COPRIMOZZO BIANCO	WHITE HUB CAP	COUVRE-MOYEU BLANCHE	WEISSE RADKAPPE	2
43	81007313/0	RUOTA RIGATA Ø 210	GROOVED WHEEL Ø 210	ROUE RAINUREE Ø 210	RAD M. LÄNGSPROFIL Ø 210	2
44	22110251/0	COPRIMOZZO BIANCO	WHITE HUB CAP	COUVRE-MOYEU BLANCHE	WEISSE RADKAPPE	2

**GRUPPO TRAZIONE  
REAR DRIVE  
GROUPE TRACTION  
ANTRIEB**

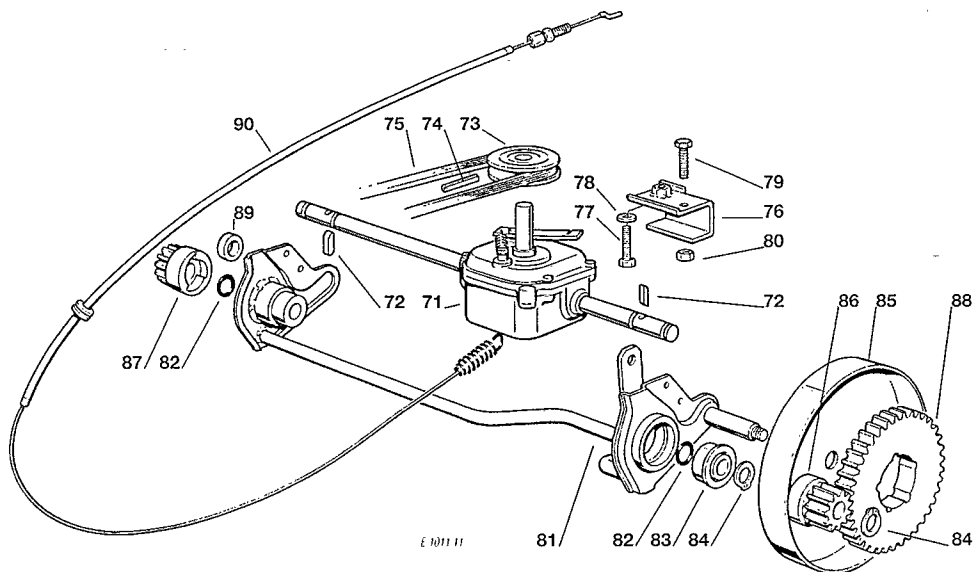

71	18652002/0	GRUPPO TRAZIONE (PLASTICA)	REAR DRIVE (PLASTIC)	GROUPE TRACTION (PLASTIQUE)	ANTRIEB (KUNSTOFF)	1
-	18652012/0	GRUPPO TRAZIONE (ALLUMINIO)	REAR DRIVE (ALUMINIUM)	GROUPE TRACTION (ALUMINIUM)	ANTRIEB (ALUMINIUM)	1
72	22328600/1	LINGUETTA TRASCINAMENTO	DRIVING KEY	CLAVETTE	MITNEHMERLAPPEN	2
73	22601904/0	PULEGGIA 4 KM/H	PULLEY 4 KM/H	POULIE 4 KM/H	RIEMENSCHLEIBE 4 KM/H	1
74	12645705/0	SPINA	PIN	GOUPILLE	STIFT	1
75	35063800/0	CINGHIA Z 27	BELT Z 27	COURROIE Z 27	RIEMEN Z 27	1
76	81005104/0	SUPPORTO TRAZIONE	SUPPORT	SUPPORT	ANTRIEBHALTER	1
77	12793600/0	VITE	SCREW	VIS	SCHRAUBE	1
78	12293200/0	DADO	NUT	ECROU	MUTTER	1
79	12689515/0	VITE	SCREW	VIS	SCHRAUBE	1
80	12154500/0	DADO	NUT	ECROU	MUTTER	1
81	81001252/1	ASSE RUOTE POSTERIORE	REAR WHEELS AXLE	AXE ROUES ARRIERE	HINTERRADER ACHSE	1
82	12019900/0	ANELLO OR	OR RING	BAGUE OR	RING OR	2
83	22122200/0	CUSCINETTO	BEARING	ROULEMENT	KUGELLAGER	2
84	12608600/0	SEEGER	SEEGER	SEEGER	SEEGER	4
85	81006846/0	PROTEZIONE RUOTE	WHEEL GUARD	PROTECTION ROUE	RAEDERSCHUTZ	2
86	22570120/0	PIGNONE SINISTRO	LEFT PINION	PIGNON GAUCHE	RECHT RITZEL	1
87	22570110/0	PIGNONE DESTRO	RIGHT PINION	PIGNON DROITE	LINCHT RITZEL	1
88	22120105/1	CORONA	RING GEAR	COURONNE	KRANZ	2
89	22170800/0	DISTANZIALE	SPACER	ENTRETOISE	DISTANZRING	1
90	81001140/0	COMANDO TRAZIONE	REAR DRIVE	GROUPE TRACTION	ANTRIEB	1

Pos. Nr.	Codice Code Kodex	Descrizione	Description	Description	Beschreibung	Q.tà Q.ty-Q.tè Menge
----------	-------------------	-------------	-------------	-------------	--------------	----------------------------

**GRUPPO COLTELLO  
BLADE ASS.Y  
GROUPE DES LAMES  
MESSERSATZT**

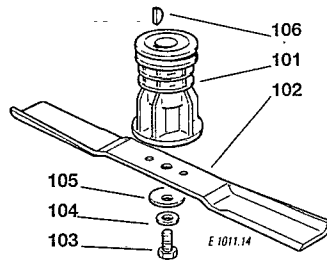

101	22465607/0	MOZZO (P.P. 62 - Ø 22)	HUB (P.T.O. 62 - Ø 22)	MOYEU (P.F. 62 - Ø 22)	HALTER (M.W. 62 - Ø 22)	1
-	22465608/0	MOZZO (P.P. 62 - Ø 25)	HUB (P.T.O. 62 - Ø 25)	MOYEU (P.F. 62 - Ø 25)	HALTER (M.W. 62 - Ø 25)	1
102	81004346/0	COLTELLO STANDARD	STANDARD BLADE	LAME STANDARD	STANDARD MESSER	1
-	81004397/0	COLTELLO ALETTATO	WINGS BLADE	LAME À AILETTES	FLUEGELMESSER	1
103	12735698/0	VITE (P.P. 62)	SCREW (P.T.O. 62)	VIS (P.F. 62)	SCHRAUBE (M.W. 62)	1
104	12523080/0	RONDELLA	WASHER	RONDELLE	SCHEIBE	1
105	22160400/0	DISCO ELASTICO	ELASTIC WASHER	RONDELLE ELASTIQUE	ELASTISCHE SCHEIBE	1
106	12139100/0	LINGUETTA (P.P. Ø 22)	FEATHER (P.T.O. Ø 22)	CLAVETTE (P.F. Ø 22)	KEIL (M.W. Ø 22)	1
-	12139150/0	LINGUETTA (P.P. Ø 25)	FEATHER (P.T.O. Ø 25)	CLAVETTE (P.F. Ø 25)	KEIL (M.W. Ø 25)	1

**SACCO RACCOGLIERBA E DOTAZIONE  
GRASS-CATCHER AND SCREWS OUTFITS  
BAC DE RAMASSAGE ET DOTATION VISSERIE  
GRASFANGKORB UND SCHRAUBENSATZ**

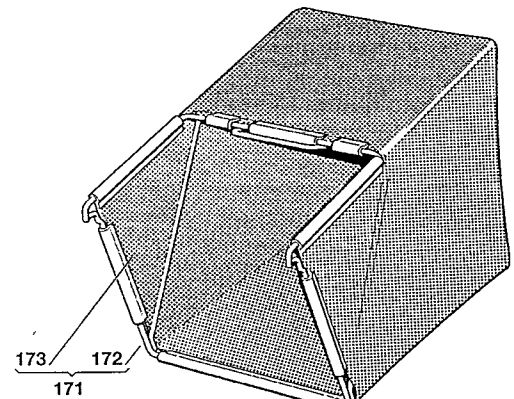
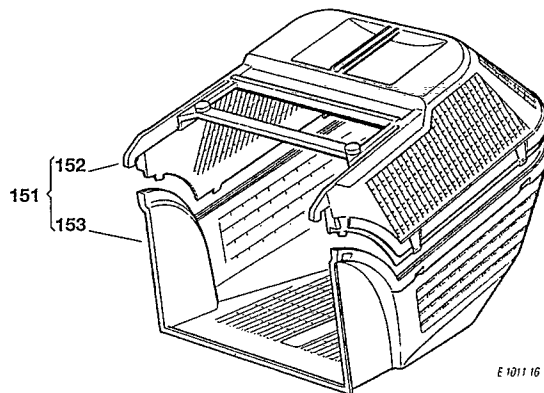

151	94004000/0	SACCO COMPLETO	COMPLETE GRASS-BOX	BAC COMPLET	KOMPLETTER KORB	1
152	22486073/0	PORTE SUPERIORE SACCO	UPPER GRASS-BOX	PARTIE SUPERIEURE SAC	KORB OBERTEIL	1
153	22486074/0	PORTE INFERIORE SACCO	LOWER GRASS-BOX	PARTIE INFERIEURE SAC	KORB UNTERTEIL	1
171	94005000/0	ASSIEME SACCO TELA	CANVASS GRASSCATCHER ASS.Y	ENSEMBLE SAC EN TOILE	KOMPLETTER SACK	1
172	81006418/0	TELAIO	CHASSIS	CHASSIS	RAHMEN	1
173	81002105/0	TELA SACCO	FABRIC BOX	TOILE POUR SAC	TUCK FÜR SACK	1
-	81008595/0	DOTAZIONE VITERIA	SCREWS OUTFIT	DOTATION VISSERIE	SCHRAUBEN SATZ	1