

panda kiwi BRAVO

350 gHK 1993

VISTE ESPLOSE
EXPLODED VIEWS
VUES ECLATEES
SPRENGZEICHNUNGEN

K 350
P 350
B 350

2 Soastk Rapid 33
Mod. 1993

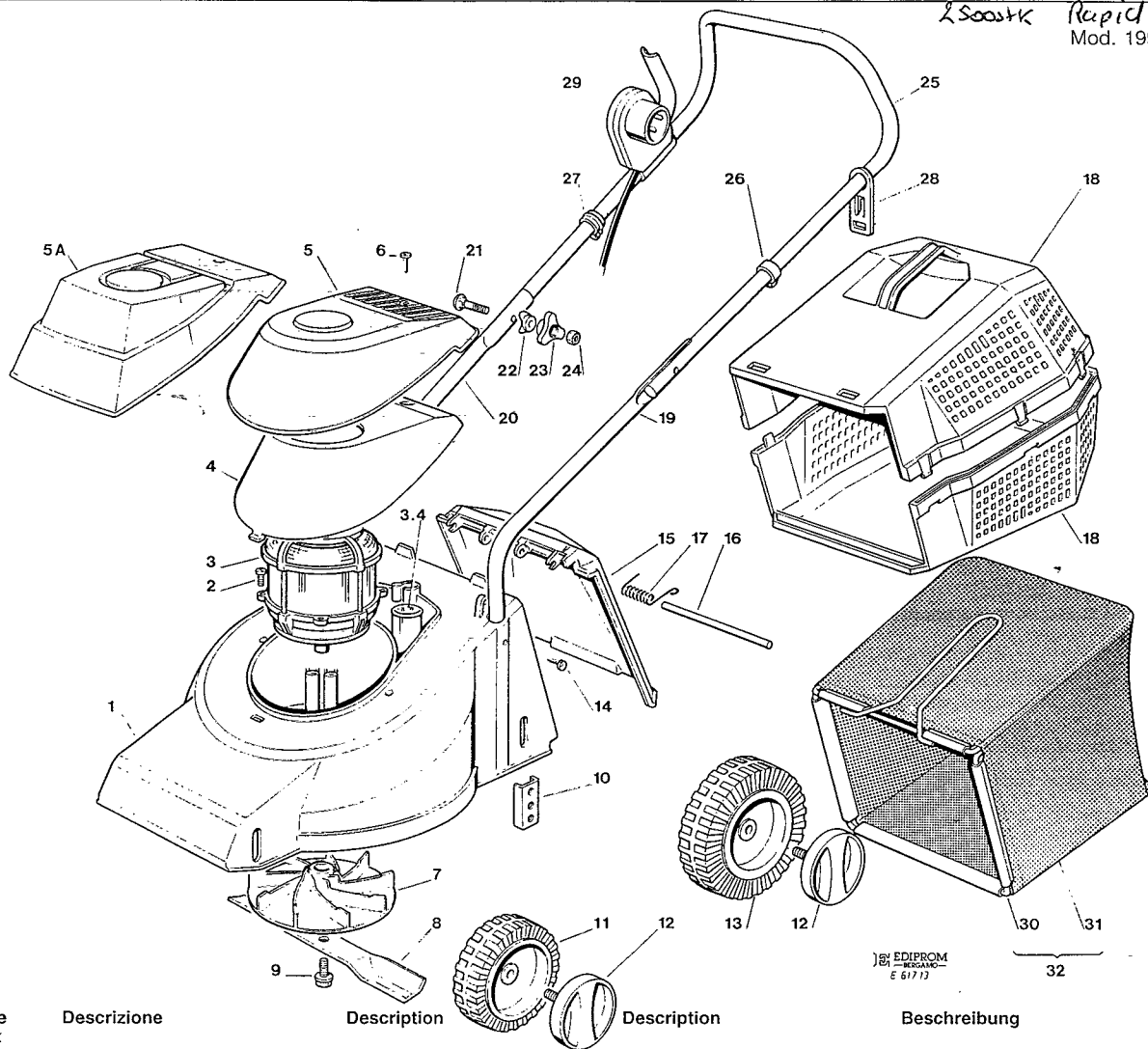

EDIPROM
E 61713

Pos. Nr.	Codice Kodex Code	Descrizione	Description	Description	Beschreibung	Q.tà Q.ty Q.tè Menge
1	81001015/1	ASS. CHASSIS VERDE (K)	DECK ASS'Y GREEN (K)	ENS. CHASSIS VERT (K)	GEHAUSE SATZ GUEN (K)	1
1A	81001036/1	ASS. CHASSIS ROSSO (P)	DECK ASS'Y RED (P)	ENS. CHASSIS ROUGE (P)	GEHAUSE SATZ ROT (P)	1
1B	81001037/1	ASS. CHASSIS GIALLO	DECK ASS'Y YELLOW	ENS. CHASSIS JAUNE	GEHAUSE SATZ GELB	1
1C	81001052/1	ASS. CHASSIS GRIGIO	DECK ASS'Y GREY	ENS. CHASSIS GRIS	GEHAUSE SATZ GRAU	1
1D	81001072/1	ASS. CHASSIS CELESTE	DECK ASS'Y LIGHT BLUE	ENS. CHASSIS BLEU CIEL	GEHAUSE SATZ HIMMELBLAU	1
2	12735410/0	VITE	SCREW	VIS	SCHRAUBE	4
3	18563024/2	MOTORE IBMEI 800W (220V) S/F	IBMEI MOTOR 800W (220V) W/B	MOTEUR IBMEI 800W (220V) S/F	MOTOR IBMEI 800W (220V) O/B	1
3A	18563034/2	MOTORE IBMEI 800W (220V) C/F	IBMEI MOTOR 800W (220V) W/B	MOTEUR IBMEI 800W (220V) A/F	MOTOR IBMEI 800W (220V) M/B	1
3B	18563041/1	MOTORE IBMEI 800W (240V) S/F	IBMEI MOTOR 800W (240V) W/B	MOTEUR IBMEI 800W (240V) S/F	MOTOR IBMEI 800W (240V) O/B	1
3C	18563040/1	MOTORE IBMEI 800W (240V) C/F	IBMEI MOTOR 800W (240V) W/B	MOTEUR IBMEI 800W (240V) A/F	MOTOR IBMEI 800W (240V) M/B	1
3D	18563007/0	MOTORE RST 900W (220V) C/F	RST MOTOR 900W (220V) W/B	MOTEUR RST 900W (220V) A/F	MOTOR RST 900W (220V) M/B	1
3E	18398026/1	FLANGIA INF.	LOWER FLANGE	BRIDE INF	UNTERFLANSCH	1
3F	18398025/3	FLANGIA SUP.	UPPER FLANGE	BRIDE SUP.	OBERFLANSCH	1
3-4	18222034/0	CONDENSATORE 8µF	CONDENSER 8µF	CONDENSATEUR 8µF	KONDENSATOR 8µF	1
4	22055032/0	SUP. CAPOTTINA	COVER SUPPORT	SUPPORT CAPOT	HAUBEHALTER	1
5	81002006/0	ASS. COPOTTINA (KIWI)	COVER ASS'Y (KIWI)	ENS. CAPOT (KIWI)	KOMPLETTE HAUBE (KIWI)	1
5A	81002007/0	ASS. COPOTTINA (PANDA)	COVER ASS'Y (PANDA)	ENS. CAPOT (PANDA)	KOMPLETTE HAUBE (PANDA)	1
6	12728680/0	VITE	SCREW	VIS	SCHRAUBE	1
7	22465602/0	MOZZO	HUB	MOYEU	HALTER	1
8	81004115/0	COLTELLO STANDARD	STANDARD BLADE	LAME STANDARD	STANDARD MESSER	1
8A	81004116/0	COLTELLO ALETTATO	WINGS BLADE	LAME A AILETTES	FLUEGEL MESSER	1
9	81004352/0	VITE	SCREW	VIS	SCHRAUBE	1
10	22785087/1	SUPP RUOTE	WHEELS SUPPORT	SUPPORT ROUES	RAEDEHALTER	4
11	22686081/0	RUOTA Ø130	WHEEL Ø130	ROUE Ø130	RAD Ø130	2
12	81004348/0	COPRIMOZZO BIANCO	HUB COVER WHITE	COUVRE-MOYEU BLANCHE	RADKAPPE WEIß	4
12A	81004347/0	COPRIMOZZO GIALLO	YELLOW HUB CAP	COUVRE-MOYEU-JOUNE	RADKAPPE GELB	4
13	22686082/0	RUOTA Ø160	WHEEL Ø160	ROUE Ø160	RAD Ø160	2
14	12728450/0	VITE	SCREW	VIS	SCHRAUBE	2
15	22600024/0	PARASSASSI	STONE GUARD	PARE PIERRES	PRALLBLECH	1

CASTEL GARDEN EQUIPMENT spa

I - 31033 CASTELFRANCO VENETO - ITALY
TF (0423) 493161 - TX 433359 GARDEN ITALY
FAX (0423) 498404

CN 71503057/0
Printed in Italy by TYP O

Pos. Nr.	Codice Kodex Code	Descrizione	Description	Description	Beschreibung	Q.tà Q.ty Q.té Menge
16	22512530/0	PERNO	PIN	PIVOT	BOLZEN	1
17	22450250/0	MOLLA	SPRING	RESSORT	FEDER	1
18	22486040/0	PARTE INF.-SUP. SACCO	UPPER.LOWER HANDLE	PARTIE SUP.-INF. BAC	OBER-UNTERKORB	2
19	81006940/0	MANICO INF. SX	L. LOWER HANDLE	MANCHERON INF. G.	L. UNTERHOLM	1
20	81006939/0	MANICO INF. DX	R. LOWER HANDLE	MANCHERON INF. D.	R. UNTERHOLM	1
21	12819120/0	VITE	SCREW	VIS	SCHRAUBE	2
22	22680006/1	RONDELLA	WASHER	RONDELLE	SCHEIBE	2
23	22399900/0	MANOPOLINA	KNOB	POIGNEE	GRIFF	2
24	12293200/0	DADO	NUT	ECROU	MUTTER	2
25	81006941/0	PARTE SUP. MANICO	UPPER HANDLE	PARTIE SUP. MANCHERON	OBERHOLM	1
26	22192150/0	FERMACAVO	FAIRLEAD	FIXATION CABLE	KABELBEFESTIGUNG	1
27	22192000/1	FASCETTA ANCORAGGIO	ANCHOR CLAMP	BANDE ANCRGE GAINÉ	BOWDENZUGHALTER	1
28	22195101/1	FERMACAVO	FAIRLEAD	FIXATION CABLE	KABELBEFESTIGUNG	1
29	18710606/0	SALVAMOTORE MM CEE 3,6 AMP. (220/240V) KIWI/PANDA	MOTOR PROTECTION MM CEE 3,6 AMP. (220/240V) KIWI/PANDA	PROTEGE MOTEUR MM CEE 3,6 AMP. (220/240V) KIWI/PANDA	MOTORSCHUTZSCHALTER MM CEE 3,6 AMP. (220/240V) KIWI/PANDA	1
29A	18710607/0	SALVAMOTORE MM SEV 3,6 AMP (220/240V) KIWI/PANDA	MOTOR PROTECTION MM SEV 3,6 AMP (220/240V) KIWI/PANDA	PROTEGE MOTEUR MM SEV 3,6 AMP (220/240V) KIWI/PANDA	MOTORSCHUTZSCHALTER 3,6 AMP (220-240V) KIWI/PANDA	1
29B	18710571/0	SALVAMOTORE TRIPUS 4 AMP. (220V) BRAVO	MOTOR PROTECTION TRIPUS 4 AMP (220V) BRAVO	PROTEGE MOTEUR TRIPUS 4 AMP. (220V) BRAVO	MOTORSCHUTZSCHALTER TRIPUS 4 AMP. (220V) BRAVO	1
29C	18710611/0	SALVAMOTORE 7 AMP. CEE (900 W RST) KIWI/PANDA	MOTOR PROTECTION CEE 7 AMP. (900 W RST) KIWI/PANDA	PROTEGE MOTEUR CEE 7 AMP. (900 W RST) KIWI/PANDA	MOTORSCHUTZSCHALTER CEE 7 AMP. (900 W RST) KIWI/PANDA	1
30	81006414/0	TELAIO	CHASSIS	CHASSIS	RAHMEN	1
31	81002107/0	SACCO TELA	FABRIC BOX	SAC EN TOILE	GRASSFANGSACK	1
32	97006000/0	ASS. SACCO TELA	CANVASS GRASSCATCHER ASS'Y	ENSEMBLE SAC EN TOILE	KOMPLETTER SACK	1
-	81008592/0	DOTAZIONE VITERIA	SCREWS OUTFIT	DOTATION VISSERIE	SCHRAUBEN SATZ	1