

PARTS LIST

BRUSHCUTTERS

**BC435DLM-1
BC435DWM-1**

**BC435DLM-1
BC435DWM-1**

APPLICABLE SERIAL NUMBERS:

DRIVE UNIT 700101 and up
ENGINE UNIT 600101 and up

Fig.1 CUTTER GROUP

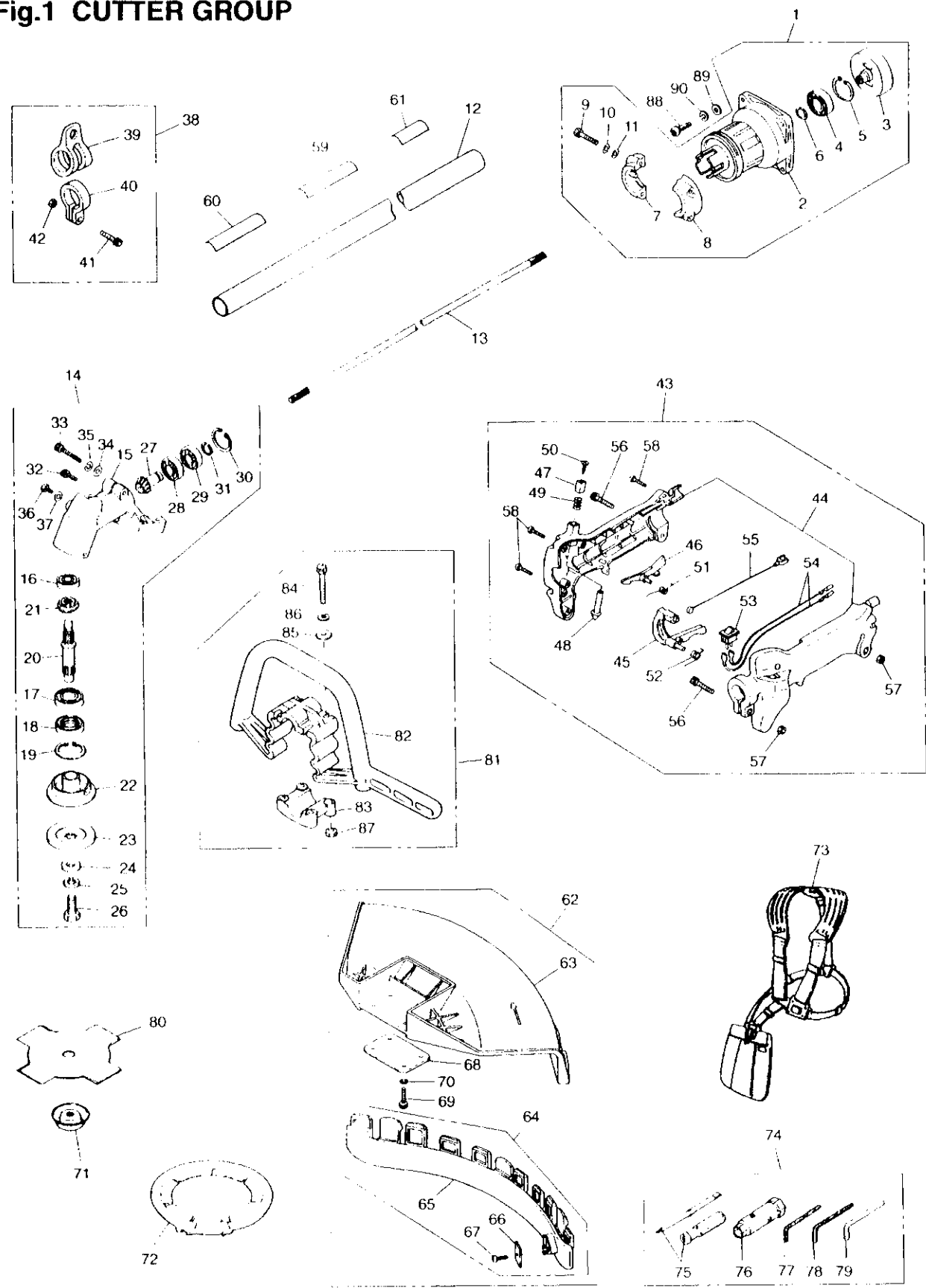

Fig.1 CUTTER GROUP

Key#	PART NUMBER	DESCRIPTION	Q'TY /UNIT	NOTE	Key#	PART NUMBER	DESCRIPTION	Q'TY /UNIT	NOTE
1	D10835	HOUSING ASSY	1		65	D10654	•• PLATE	1	
2	D10919	• HOUSING COMP	1		66	D10591	•• BLADE	1	
3	D10556	• DRUM	1		67	D10587	•• SCREW	1	
4	D10218	• BEARING	1		68	D10656	• PLATE	1	
5	5131	• RING	1		69	5223	• BOLT	4	M5x16
6	D10219	• RING	1		70	1195	• WASHER	4	
7	D10742	• CLAMP	1		71	D10522	COVER(BOLT)	1	
8	D10743	• CLAMP	1		72	D10540	COVER(BLADE)	1	
9	1172	• BOLT	2		73	6220-17201	STRAP ASSY	1	
10	1195	• WASHER	2		74	D10597	TOOL KIT	1	
11	1185	• WASHER	2		75	D10332	• DRIVER	1	
12	D10574	PIPE COMP	1		76	D10598	• SOCKET	1	
13	D10557	SHAFT	1		77	D10334	• WRENCH	1	
14	D10563	GEARCASE ASSY	1		78	1316	• WRENCH	1	
15	D10602	• GEARCASE	1		79	D10709	• BAR	1	
16	D10270	• BEARING	1		80	6298-14343	SAW	1	
17	D10578	• BEARING	1		81	D10573	HANDLE ASSY	1	
18	D10549	• SEAL	1		82	D10052	• HANDLE	1	
19	5131	• RING	1		83	D10053	• CLAMP	1	
20	D10546	• SHAFT	1		84	D10667	• SCREW	4	M5x35
21	D10545	• GEAR	1		85	1185	• WASHER	4	
22	6251-13240	• HOLDER(A)	1		86	1195	• WASHER	4	
23	3540-13251	• HOLDER(B)	1		87	1205	• NUT	4	
24	D10590	• WASHER	1		88	1174	BOLT	4	M6x20
25	D10589	• WASHER	1		89	1186	WASHER	4	
26	D10595	• BOLT	1		90	D10217	WASHER	4	
27	D10547	• PINION	1						
28	D10581	• BEARING	1						
29	D10658	• BEARING	1						
30	D10348	• RING	1						
31	D10269	• RING	1						
32	D10222	• BOLT	1	M5x10					
33	D10216	• BOLT	1						
34	1186	• WASHER	1						
35	D10217	• WASHER	1						
36	D10351	• BOLT	1	M6x10					
37	1186	• WASHER	1						
38	D10713	HANGER ASSY	1						
39	D10058	• HANGER	1						
40	D10057	• CLAMP	1						
41	1171	• BOLT	1						
42	1205	• NUT	1						
43	D10754	GRIP ASSY	1						
44	D10605	• BODY	1						
45	D10613	• LEVER	1						
46	D10612	• LEVER	1						
47	D10610	• BUTTON A	1						
48	D10611	• BUTTON B	1						
49	D10584	• SPRING	1						
50	D10802	• SCREW	1						
51	D10583	• SPRING	1						
52	D10579	• SPRING	1						
53	D10716	• SWITCH	1						
54	D10800	• CORD	2						
55	D10585	• CABLE	1						
56	1170	• BOLT	2	M5x20					
57	1205	• NUT	2						
58	D10921	• SCREW	3	L20					
59	D10894	PLATE NAME	1						
60	D10560	PLATE CAUTION	1						
61	_____	No PLATE	1						
62	D10570	GUARD ASSY	1						
63	D10655	• GUARD	1						
64	D10653	• PLATE COMP	1						

Fig.2 ENGINE GROUP

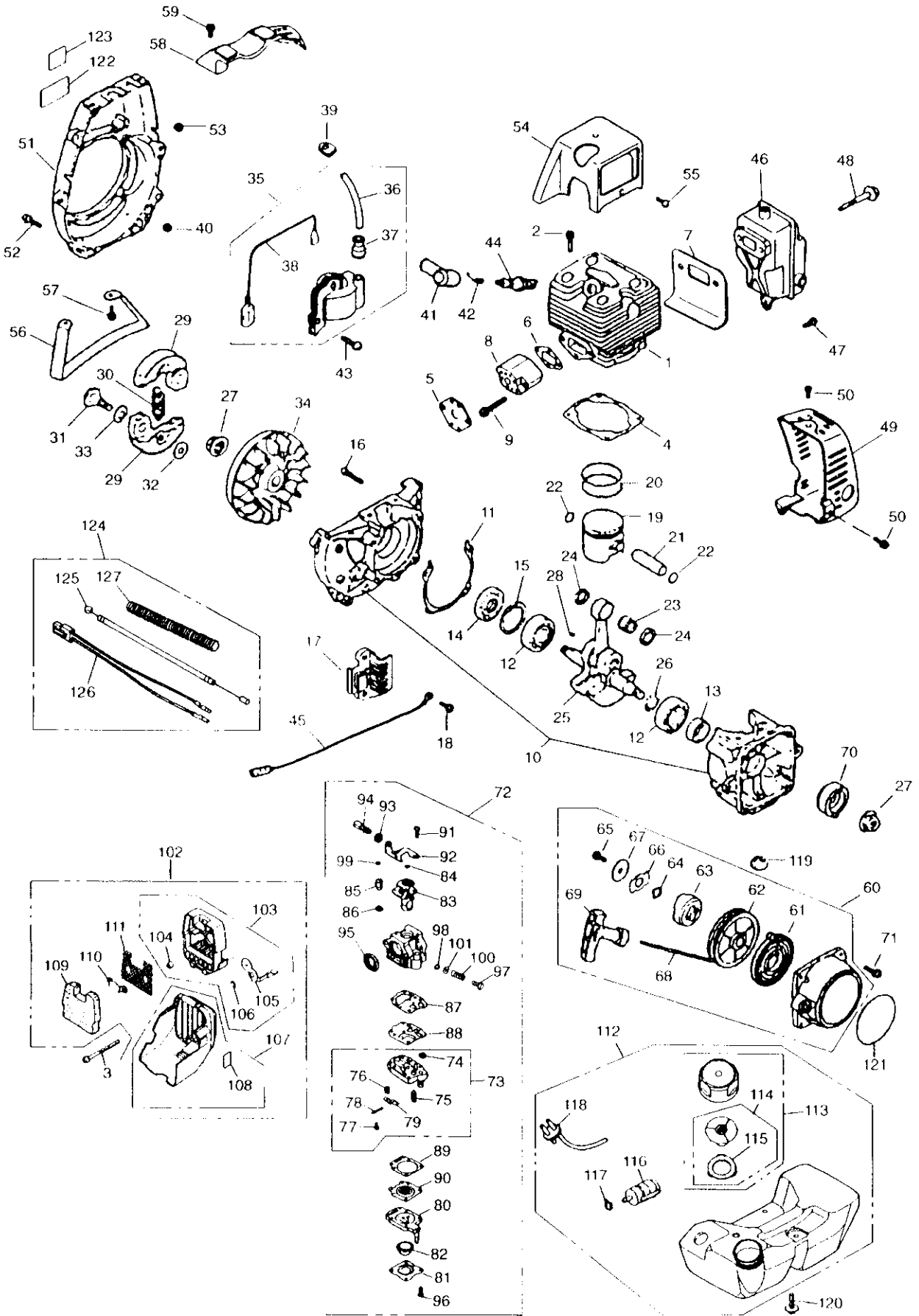

Fig.2 ENGINE GROUP

Key#	PART NUMBER	DESCRIPTION	Q'TY /UNIT	NOTE	Key#	PART NUMBER	DESCRIPTION	Q'TY /UNIT	NOTE
1	1400-12113	CYLINDER	1		65	1483-75270	• SCREW	1	
2	3310-12281	BOLT	4		66	1487-75160	• RETAINER	1	
3	0260-30560	SCREW	2		67	1487-75170	• WASHER	1	
4	1400-13121	GASKET	1		68	1400-75160	• ROPE	1	
5	1460-13131	GASKET	1		69	1400-75170	• KNOB	1	
6	1400-13142	GASKET	1		70	1487-75211	PULLEY	1	
7	1400-13150	GASKET	1		71	0263-90520	SCREW	4	
8	1460-13163	INSULATOR	1		72	1460-81002	CARBURETOR ASS'Y	1	
9	00260-30540	SCREW	2		73	1850-81450	• BODY ASS'Y	1	
10	1400-21100	CRANKCASE COMP	1		74	3306-81380	•• SCREEN	1	
11	1400-21140	GASKET	1		75	3356-81310	•• VALVE	1	
12	06030-06202	BEARING	2		76	1850-81270	•• SPRING	1	
13	1520-21220	SEAL	1		77	1850-81220	•• SCREW	1	
14	1400-21220	SEAL	1		78	3310-81250	•• PIN	1	
15	04065-03515	RING	1		79	3310-81230	•• LEVER	1	
16	01252-30530	BOLT	4		80	1850-81490	• BODY	1	
17	2155-21311	GURAD	1		81	1850-81520	• COVER	1	
18	0263-90514	SCREW	2		82	1751-81510	• PUMP	1	
19	1400-41111	PISTON	1		83	1460-81150	• VALVE	1	
20	1400-41220	HING	2		84	1881-81160	• PLUG	1	
21	1400-41310	PIN	1		85	1881-81140	• SWIVEL	1	
22	3350-41320	RING	2		86	1751-81130	• RING	1	
23	1400-41410	BEARING	1		87	1065-81410	• GASKET	1	
24	2616-41510	WASHER	2		88	1065-81420	• DIAPHRAGM	1	
25	1400-42002	CRANKSHAFT COMP	1		89	1850-81470	• GASKET	1	
26	1300-42410	SHIM	0/1		90	3310-81260	• DIAPHRAGM	1	
27	1400-43230	NUT	2		91	1752-81110	• SCREW	2	
28	1000-43240	KEY	1		92	1460-81350	• BRACKET	1	
29	1075-51113	SHOE	2		93	1751-81180	• NUT	1	
30	1075-51220	SPRING	1		94	1601-81180	• SCREW	1	
31	1200-51211	SCREW	2		95	1881-81130	• RING	1	
32	1200-51230	WASHER	2		96	1850-81530	• SCREW	4	
33	1200-51240	WASHER	2		97	1460-81610	• NEEDLE	1	
34	2073-71110	ROTOR	1		98	1881-81240	• O-RING	1	
35	2113-71200	COIL ASS'Y	1		99	1601-81810	• CAP	1	
36	2113-71220	• CORD	1		100	1491-81160	• SPRING	1	
37	2616-71320	• CAP	1		101	1881-81190	• WASHER	1	
38	2313-71240	• CORD	1		102	1460-82002	CLEANER ASS'Y	1	
39	5500-72130	GROMMET	1		103	1460-82102	• BODY ASS'Y	1	
40	1100-72120	GROMMET	1		104	1601-82120	•• SLEEVE	2	
41	1900-72111	CAP	1		105	1460-82131	•• SHUTTER	1	
42	1900-72120	SPRING	1		106	1601-82140	•• WASHER	1	
43	0263-90520	SCREW	2		107	1601-82202	• COVER COMP	1	
44	5535-73110	SPARK PLUG	1		108	1133-82060	•• LABEL	1	
45	2313-71250	CORD	1		109	1601-82311	• ELEMENT	1	
46	1461-15110	MUFFLER	1		110	1601-82320	• PLATE	1	
47	0263-90512	SCREW	1		111	1601-82351	• SCREEN	1	
48	1400-15150	BOLT	2		112	2313-85000	TANK ASS'Y	1	
49	1461-15410	COVER	1		113	2116-85201	• CAP ASS'Y	1	
50	0263-90512	SCREW	3		114	2116-85300	•• VALVE COMP	1	
51	1400-31113	COVER	1		115	1600-85322	•• PACKING	1	
52	3310-12281	BOLT	4		116	3302-85400	• FILTER ASS'Y	1	
53	1100-72120	GROMMET	1		117	1260-85460	• CLIP	1	
54	2313-32110	COVER	1		118	1460-85801	• PIPE COMP	1	
55	0263-90512	SCREW	2		119	2313-86290	SPACER	3	
56	1460-31910	STAND	1		120	1460-85850	SCREW	3	
57	3310-31720	BOLT	2		121	1403-75411	LABEL	1	
58	1460-33110	GUARD	1		122	1660-31121	LABEL	1	
59	0263-90520	SCREW	2		123	2634-31420	LABEL(CE)	1	
60	1487-75100	RECOIL ASS'Y	1		124	2319-83000	CABLE ASS'Y	1	
61	1180-75221	• SPRING	1		125	2319-83100	• CABLE COMP	1	
62	1487-75120	• REEL	1		126	2319-73200	• CORD COMP	1	
63	1487-75140	• DOG	1		127	2319-73310	• TUBE	1	
64	1861-75150	• WASHER	1						

Fig.1 CUTTER GROUP

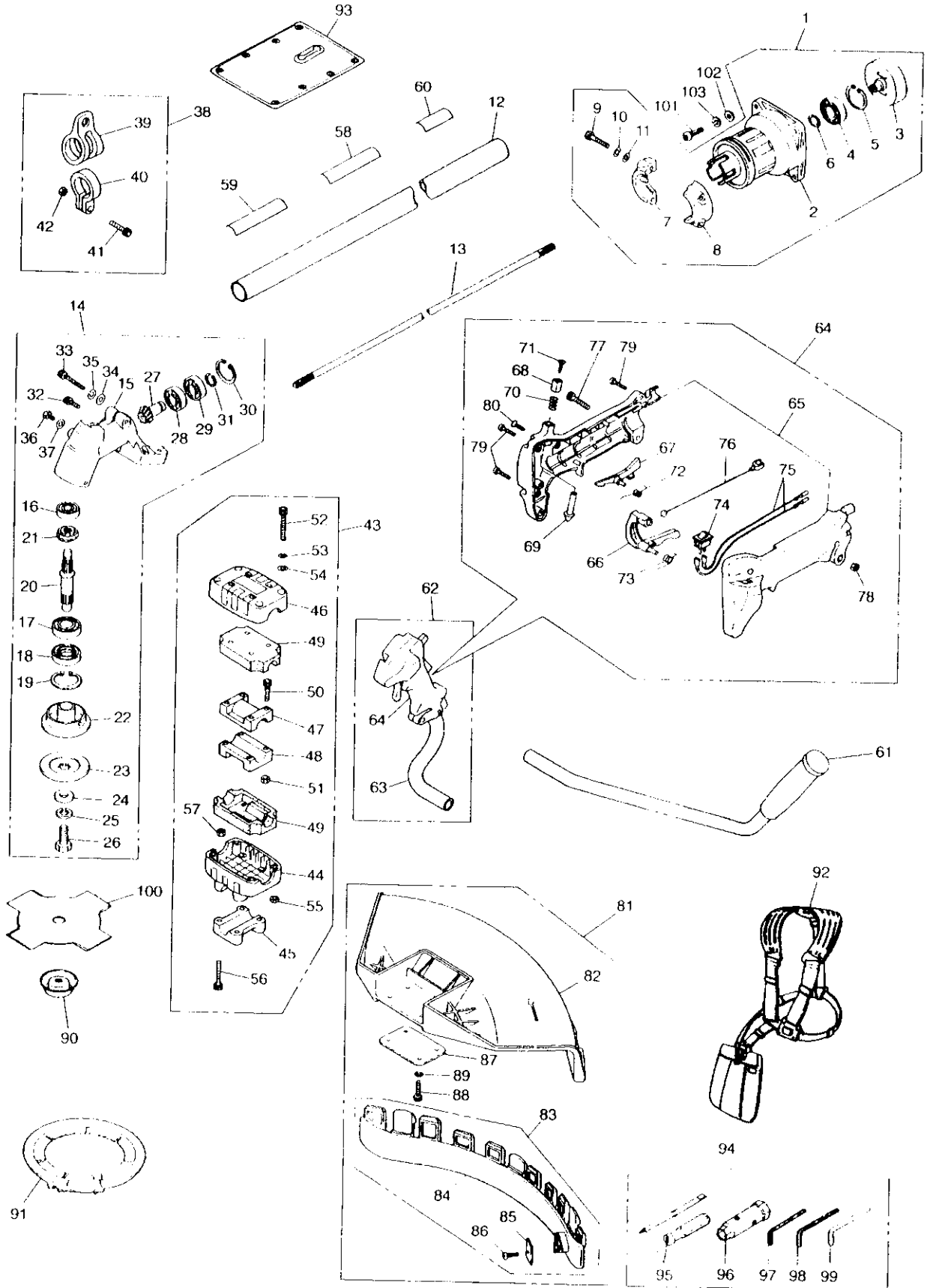

Fig.1 CUTTER GROUP

Key#	PART NUMBER	DESCRIPTION	Q'TY /UNIT	NOTE	Key#	PART NUMBER	DESCRIPTION	Q'TY /UNIT	NOTE
1	D10835	HOUSING ASSY	1		65	D10606	•• BODY	1	
2	D10919	• HOUSING COMP	1		66	D10613	•• LEVER	1	
3	D10556	• DRUM	1		67	D10612	•• LEVER	1	
4	D10218	• BEARING	1		68	D10610	•• BUTTON A	1	
5	5131	• RING	1		69	D10611	•• BUTTON B	1	
6	D10219	• RING	1		70	D10584	•• SPRING	1	
7	D10742	• CLAMP	1		71	D10802	•• SCREW	1	
8	D10743	• CLAMP	1		72	D10583	•• SPRING	1	
9	1172	• BOLT	2		73	D10579	•• SPRING	1	
10	1195	• WASHER	2		74	D10716	•• SWITCH	1	
11	1185	• WASHER	2		75	D10800	•• CORD	2	
12	D10574	PIPE COMP	1		76	D10585	•• CABLE	1	
13	D10557	SHAFT	1		77	1170	•• BOLT	1	M5x20
14	D10563	GEARCASE ASSY	1		78	1205	•• NUT	1	
15	D10602	• GEARCASE	1		79	D10921	•• SCREW	3	L20
16	D10270	• BEARING	1		80	D10323	•• SCREW	1	
17	D10578	• BEARING	1		81	D10570	GUARD ASSY	1	
18	D10549	• SEAL	1		82	D10655	• GUARD	1	
19	5131	• RING	1		83	D10653	• PLATE COMP	1	
20	D10546	• SHAFT	1		84	D10654	•• PLATE	1	
21	D10545	• GEAR	1		85	D10591	•• BLADE	1	
22	6251-13240	• HOLDER(A)	1		86	D10587	•• SCREW	1	
23	3540-13251	• HOLDER(B)	1		87	D10656	• PLATE	1	
24	D10590	• WASHER	1		88	5223	• BOLT	4	M5x16
25	D10589	• WASHER	1		89	1195	• WASHER	4	
26	D10595	• BOLT	1		90	D10522	COVER(BOLT)	1	
27	D10547	• PINION	1		91	D10540	COVER(BLADE)	1	
28	D10581	• BEARING	1		92	6220-17201	HARNESS ASSY	1	
29	D10658	• BEARING	1		93	D10397	PROTRACTOR	1	
30	D10348	• RING	1		94	D10597	TOOL KIT	1	
31	D10269	• RING	1		95	D10332	• DRIVER	1	
32	D10222	• BOLT	1	M5x10	96	D10598	• SOCKET	1	
33	D10216	• BOLT	1		97	D10334	• WRENCH	1	
34	1186	• WASHER	1		98	1316	• WRENCH	1	
35	D10217	• WASHER	1		99	D10709	• BAR	1	
36	D10351	• BOLT	1	M6x10	100	6298-14343	SAW	1	
37	1186	• WASHER	1		101	1174	BOLT	4	M6x20
38	D10713	HANGER ASSY	1		102	1186	WASHER	4	
39	D10058	• HANGER	1		103	D10217	WASHER	4	
40	D10057	• CLAMP	1						
41	1171	• BOLT	1						
42	1205	• NUT	1						
43	D10577	BRACKET ASSY	1						
44	D10083	• BRACKET	1						
45	D10084	• CAP-L	1						
46	D10077	• CAP-U	1						
47	D10054	• CLAMP	1						
48	D10055	• CLAMP	1						
49	D10078	• ABSORBER	2						
50	D10721	• BOLT	4						
51	1205	• NUT	4						
52	D10588	• BOLT	4						
53	1195	• WASHER	4						
54	1185	• WASHER	4						
55	1205	• NUT	4						
56	1173	• BOLT	4						
57	1205	• NUT	4						
58	D10895	PLATE NAME	1						
59	D10560	PLATE CAUTION	1						
60	—	No PLATE	1						
61	D10735	HANDLE-L COMP	1						
62	D10799	HANDLE-R COMP	1						
63	D10539	• HANDLE-R	1						
64	D10751	• GRIP ASSY	1						

Reservedelsliste for Feed-Matic snørehoved

for 'TEXAS' buskryddere

1992/1

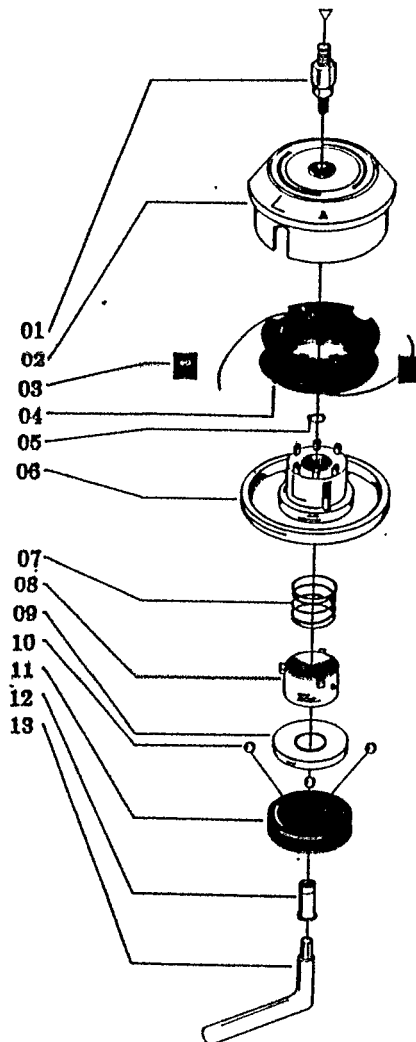

Pos.nr.	Best.nr.	Tekst
01	10-101007	Adapter for BC 220
01a	10-101008	Adapter for 340 M
01b	10-101010	Adapter for 431 M
02	10-101061	Spolehus
03	10-106003	Snørestyr
04	10-101030	Spole
05	10-103025	Låsering
06	10-101053	Bund for spolehus
06a	10-201003	Komplet bund pos. 5-12
07	10-107006	Fjeder
08	10-101069	Fjederholder
09	10-101070	Kugleskål
10	10-102073	Stålkugle
11	10-101071	Kugleholder
12	10-101056	Bolt
13	10-109006	Nøgle
14	22007100	Snørehoved for BC 220 7 MM
15	34008125	Snørehoved for 340 M 8 MM
16	43110125	Snørehoved for 431 M 10 MM

Fig.2 ENGINE GROUP

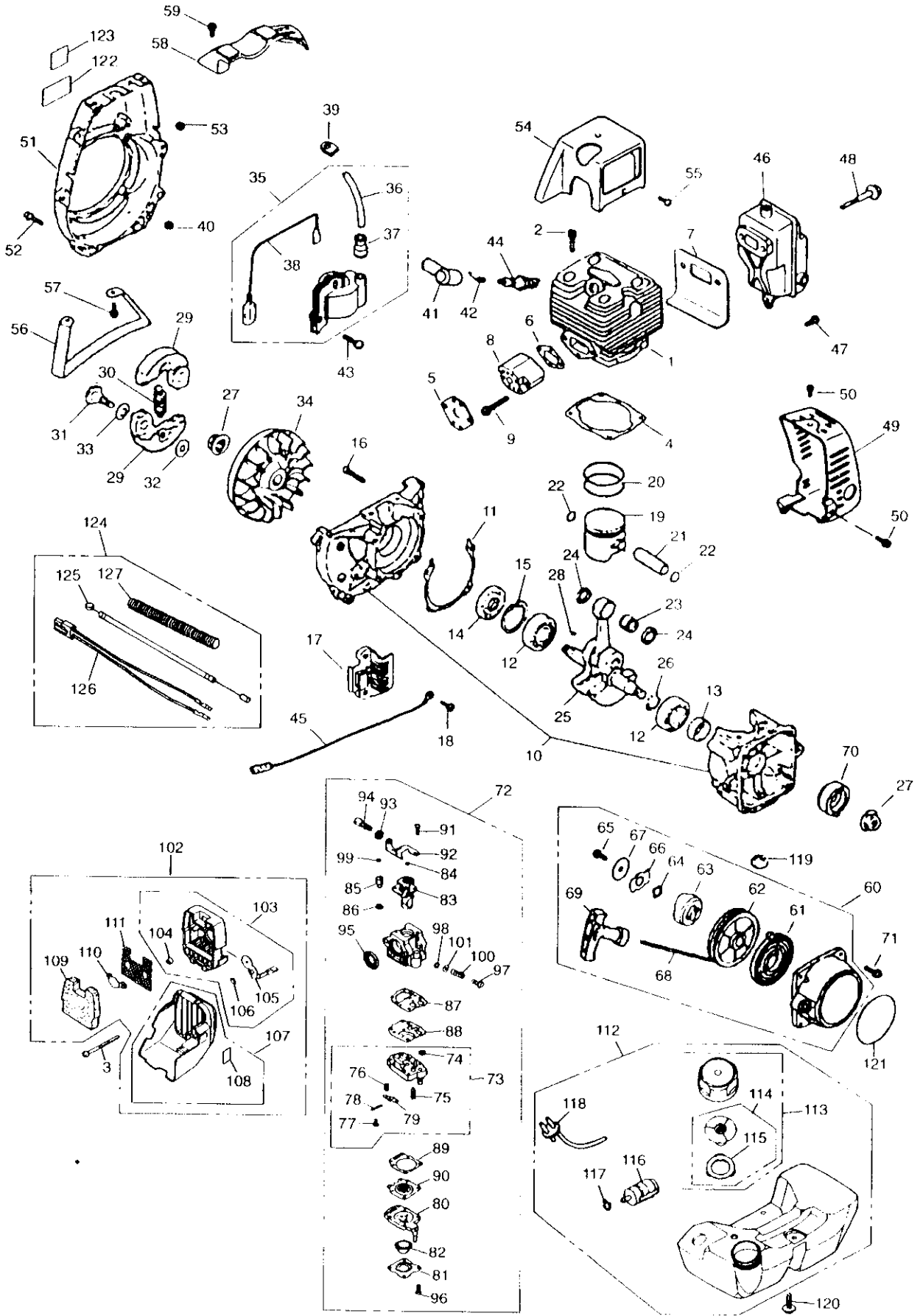

Fig.2 ENGINE GROUP

Key#	PART NUMBER	DESCRIPTION	Q'TY /UNIT	NOTE	Key#	PART NUMBER	DESCRIPTION	Q'TY /UNIT	NOTE
1	1400-12113	CYLINDER	1		65	1483-75270	• SCREW	1	
2	3310-12281	BOLT	4		66	1487-75160	• RETAINER	1	
3	0260-30560	SCREW	2		67	1487-75170	• WASHER	1	
4	1400-13121	GASKET	1		68	1400-75160	• ROPE	1	
5	1460-13131	GASKET	1		69	1400-75170	• KNOB	1	
6	1400-13142	GASKET	1		70	1487-75211	PULLEY	1	
7	1400-13150	GASKET	1		71	0263-90520	SCREW	4	
8	1460-13163	INSULATOR	1		72	1460-81002	CARBURETOR ASS'Y	1	
9	00260-30540	SCREW	2		73	1850-81450	• BODY ASS'Y	1	
10	1400-21100	CRANKCASE COMP	1		74	3306-81380	•• SCREEN	1	
11	1400-21140	GASKET	1		75	3356-81310	•• VALVE	1	
12	06030-06202	BEARING	2		76	1850-81270	•• SPRING	1	
13	1520-21220	SEAL	1		77	1850-81220	•• SCREW	1	
14	1400-21220	SEAL	1		78	3310-81250	•• PIN	1	
15	04065-03515	RING	1		79	3310-81230	•• LEVER	1	
16	01252-30530	BOLT	4		80	1850-81490	• BODY	1	
17	2155-21311	GURAD	1		81	1850-81520	• COVER	1	
18	0263-90514	SCREW	2		82	1751-81510	• PUMP	1	
19	1400-41111	PISTON	1		83	1460-81150	• VALVE	1	
20	1400-41220	RING	2		84	1881-81160	• PLUG	1	
21	1400-41310	PIN	1		85	1881-81140	• SWIVEL	1	
22	3350-41320	RING	2		86	1751-81130	• RING	1	
23	1400-41410	BEARING	1		87	1065-81410	• GASKET	1	
24	2616-41510	WASHER	2		88	1065-81420	• DIAPHRAGM	1	
25	1400-42002	CRANKSHAFT COMP	1		89	1850-81470	• GASKET	1	
26	1300-42410	SHIM	0/1		90	3310-81260	• DIAPHRAGM	1	
27	1400-43230	NUT	2		91	1752-81110	• SCREW	2	
28	1000-43240	KEY	1		92	1460-81350	• BRACKET	1	
29	1075-51113	SHOE	2		93	1751-81180	• NUT	1	
30	1075-51220	SPRING	1		94	1601-81180	• SCREW	1	
31	1200-51211	SCREW	2		95	1881-81130	• RING	1	
32	1200-51230	WASHER	2		96	1850-81530	• SCREW	4	
33	1200-51240	WASHER	2		97	1460-81610	• NEEDLE	1	
34	2073-71110	ROTOR	1		98	1881-81240	• O-RING	1	
35	2113-71200	COIL ASS'Y	1		99	1601-81810	• CAP	1	
36	2113-71220	• CORD	1		100	1491-81160	• SPRING	1	
37	2616-71320	• CAP	1		101	1881-81190	• WASHER	1	
38	2313-71240	• CORD	1		102	1460-82002	CLEANER ASS'Y	1	
39	5500-72130	GROMMET	1		103	1460-82102	• BODY ASS'Y	1	
40	1100-72120	GROMMET	1		104	1601-82120	•• SLEEVE	2	
41	1900-72111	CAP	1		105	1460-82131	• SHUTTER	1	
42	1900-72120	SPRING	1		106	1601-82140	•• WASHER	1	
43	0263-90520	SCREW	2		107	1601-82202	• COVER COMP	1	
44	5535-73110	SPARK PLUG	1		108	1133-82060	•• LABEL	1	
45	2313-71250	CORD	1		109	1601-82311	• ELEMENT	1	
46	1461-15110	MUFFLER	1		110	1601-82320	• PLATE	1	
47	0263-90512	SCREW	1		111	1601-82351	• SCREEN	1	
48	1400-15150	BOLT	2		112	2313-85000	TANK ASS'Y	1	
49	1461-15410	COVER	1		113	2116-85201	• CAP ASS'Y	1	
50	0263-90512	SCREW	3		114	2116-85300	•• VALVE COMP	1	
51	1400-31113	COVER	1		115	1600-85322	•• PACKING	1	
52	3310-12281	BOLT	4		116	3302-85400	• FILTER ASS'Y	1	
53	1100-72120	GROMMET	1		117	1260-85460	• CLIP	1	
54	2313-32110	COVER	1		118	1460-85801	• PIPE COMP	1	
55	0263-90512	SCREW	2		119	2313-86290	SPACER	3	
56	1460-31910	STAND	1		120	1460-85850	SCREW	3	
57	3310-31720	BOLT	2		121	1403-75411	LABEL	1	
58	1460-33110	GUARD	1		122	1660-31121	LABEL	1	
59	0263-90520	SCREW	2		123	2634-31420	LABEL(CE)	1	
60	1487-75100	RECOIL ASS'Y	1		124	5944-83000	CABLE ASS'Y	1	
61	1180-75221	• SPRING	1		125	5944-83100	• CABLE COMP	1	
62	1487-75120	• REEL	1		126	5944-73200	• CORD COMP	1	
63	1487-75140	• DOG	1		127	5944-73310	• TUBE	1	
64	1861-75150	• WASHER	1						