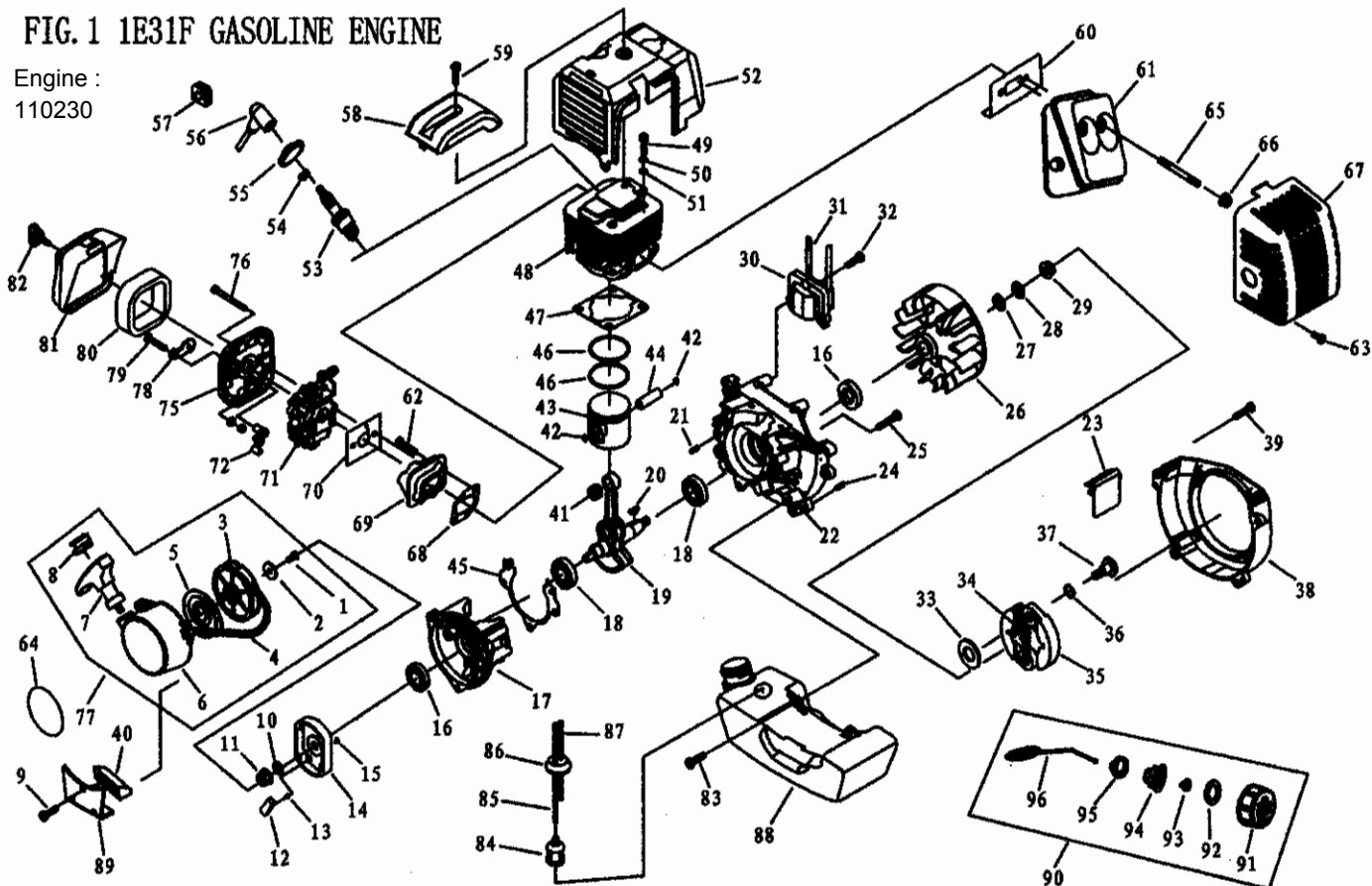

FIG. 1 1E31F GASOLINE ENGINE

Engine :
110230



NO.	PART NO.	PART NAME	QTY.	NO.	PART NO.	PART NAME	QTY.	NO.	PART NO.	PART NAME	QTY.
1	GB/T67	SCREW M5X12	1	33	1E34F-11	WASHER B	2	65	1E34F-14	BOLT	1
2	1E36F. 1-4	ROPE REEL WASHER	1	34	1E34F. 10-1	SPRING	1	66	GB/T6187	NUT M5	2
3	1E36F. 1-3	STARTER ROPE REEL	1	35	1E34F. 10. 1	EXPANDER	2	67	1E31F-4	MUFFLER COVER	1
4	1E36F1-6	ROPE (φ3. 5X860)	1	36	1E34F-13	WASHER	2	68	1E36F-2-2	GASKET	1
5	1E36F. 1-2	RECOIL SPRING	1	37	1E34F-12	SCREW PIN	2	69	1E36F-2A-2	ADMITTING PIPE	1
6	1E36F. 1. 1. 1	RECOIL STARTER BODY	1	38	1E31F. 6-2	FAN COVER	1	70	1E36F-2A-1	GASKET	1
7	1E36F. 1-1	STARTER HANDLE	1	39	GB/T9074. 13	BOLT M5×16	4	71	1E31F. 1	CARBURETOR	1
8	1E36F. 1-5	RING	1	40	1E31F-4	RUBBER COVER	1	72	1E34F. 1-2	CHOKER HANDLER	1
9	GB/T9074. 4	SCREW M4×16	3	41	1E31F. 4. 1	BEARING	1	73	1E34F. 1. 1-1	PIPE	1
10	GB/T97. 1	WASHER 8	1	42	1E31F. 4-3	RING	2	74	1E34F. 1-7	STOP RING	1
11	GB/T6170	NUT M8	1	43	1E31F. 4. 2	PISTON	1	75	1E34F. 1. 1	CLEANER INSIDE COVER	1
12	1E46FP. 4-2	START CLAW	1	44	1E31F. 4-2	PISTON PIN	1	76	GB/T9074. 4	SCREW M5X50	2
13	1E36F. 1. 2-2	START SPRING	1	45	1E31F. 8-3	GASKET	1	77	1E36F. 1	STARTER	1
14	1E36F. 1. 2-1	START REEL	1	46	1E31F. 4-1	PISTON RING	2	78	1E34F. 1-3	CHOKER	1
15	GB/T896	STOP RING 4	1	47	1E31F-2	GASKET	1	79	GB/T845	SCREW ST4. 2X12-F-H	1
16	1E36F. 2	OIL-SEAL	2	48	1E31F-1	CYLINDER	1	80	1E34F. 1-1	FILTER	1
17	1E31F. 8-2	CRANK CASE	1	49	GB/T70. 1	SCREW M5×18	4	81	1E34F. 1-4	CLEANER OUTSIDE COVER	1
18	GB/T276	BEARING 6201/P5	2	50	GB/T859	WASHER 5	4	82	1E34F. 1. 2	SCREW	1
19	1E31F. 4. 3	CRANK SHAFT	1	51	GB/T97. 1	WASHER 5	4	83	GB/T9074. 4	SCREW M5X16	1
20	GB/T1099	KEY 3X5X13	1	52	1E31F. 5	GUIDE COVER ASS'Y	1	84	1E34F. 9. 2-3	CLEANER	1
21	GB/T119	PIN B4×10	2	53	L6(LD)	SPARK PLUG	1	85	1E36F-2A. 3. 1-2	FUEL PIPE	1
22	1E31F. 8-1	CRANK CASE	2	54	1E40F-3A. 8-2	SPRING	1	86	1E36FF. 8. 1-1	PLUG	1
23	1E31F. 6-1	FLASH PAN	1	55	1E34F. 5-3	PLUG CAP	1	87	1E36F-2A. 3. 1-1	FUEL PIPE	1
24	GB/T119	PIN B4×10	2	56	1E34F. 5-2	CAP	1	88	1E31F. 7-1	FUEL TANK	1
25	GB/T9074. 4	SCREW M5X25	3	57	1E40F-5. 3-1	PLUG	1	89	1E31F-6	STAND	1
26	1E36F-235	MAGNETO ROTOR COMP.	1	58	1E36F-2-7	COVER	1	90	1E32FL. 6. 2	Fuel Tank Lid Ass'y	1
27	GB/T97. 1	WASHER 8	1	59	GB/T9074. 4	SCREW M5X20	1	91	1E32FL. 6. 2-1	Fuel Tank Lid	1
28	GB/T859	WASHER 8	1	60	1E31F-5	GASKET	2	92	CG420. 1. 3. 1-2	Gasket	1
29	GB/T6170	NUT M8	1	61	1E31F. 2	MUFFLER	1	93	EB-415. 4. 1. 1-1	Inlet	1
30	1E36F-230	IGNITION COIL COMP.	1	62	GB/T9074. 4	SCREW M5X20	2	94	1E32FL. 6. 2-2	Inside Lid	1
31	1E36F-2. 3. 1	CORD COMP.	1	63	GB/T9074. 4	SCREW M5X12	1	95	1E32FL. 6. 2-3	Inside Lid	1
32	GB/T9074. 13	BOLT M5×20	2	64	CG305F-14	LABEL	1	96	1E32FL. 6. 2-4	Chain	1

FIG. 2: CG230B BRUSH CUTTER

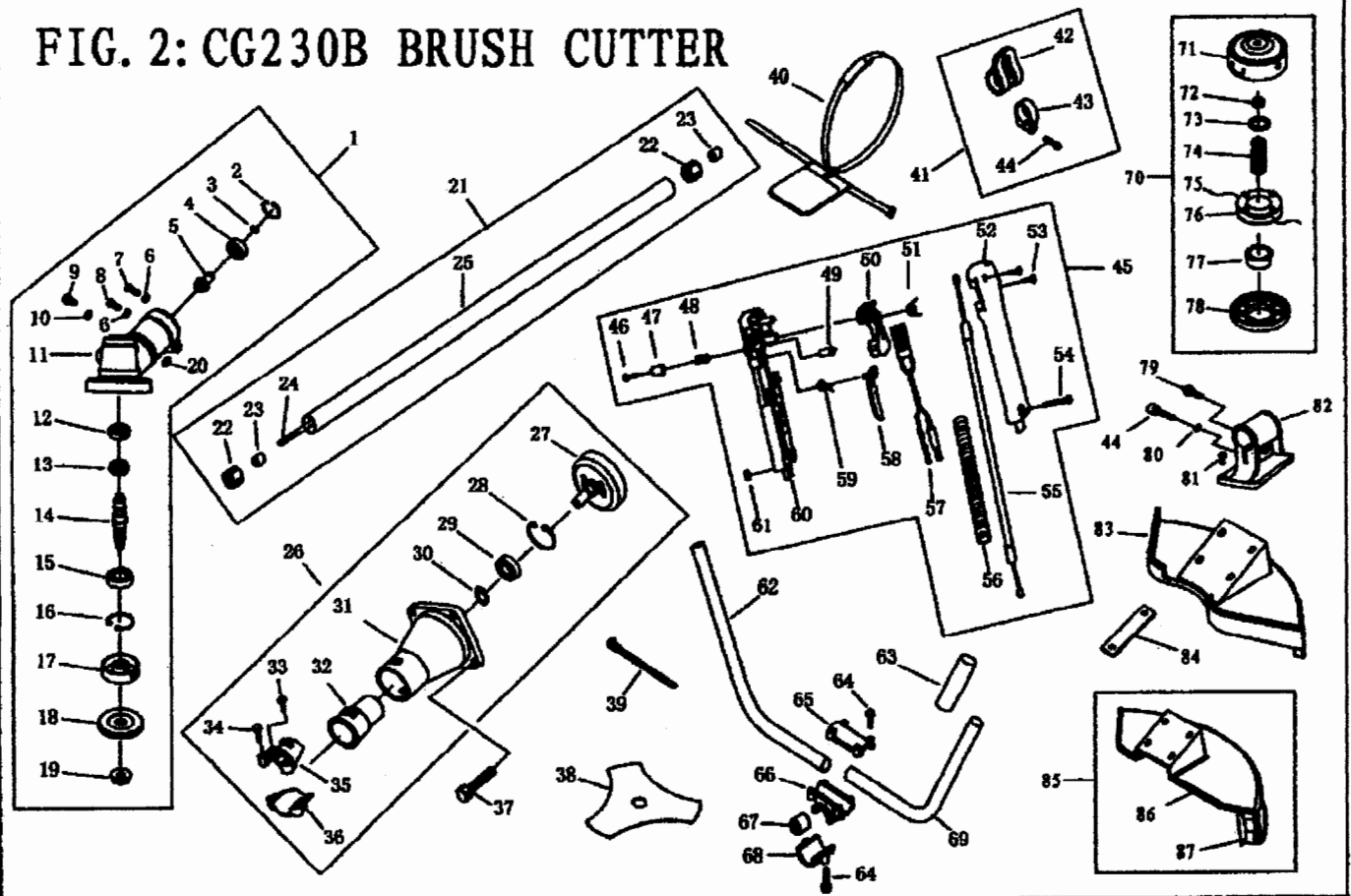

NO.	PART NO.	PART NAME	QTY.	NO.	PART NO.	PART NAME	QTY.	NO.	PART NO.	PART NAME	QTY.
1	CG230B. 5	Gear Case Ass'y	1	30	GB/T894. 1	Circlip for Hole 15	1	59	BL750. 3-2	Spring	1
2	GB/T893. 2	Circlip for Hole 24	1	31	CG261. 1-1	Clutch Case	1	60	BL750. 3-6	Box, Left	1
3	GB/T894. 1	Circlip for Shaft 9	1	32	CG260. 1H-1	Rubber Cover	1	61	GB/T889. 1	Nut M5	1
4	GB/T276	Bearing 609-RS/P5	1	33	GB/T9074. 4	Screw M5×16	1	62	CG261B. 2-1	Handgrip	1
5	CG230B. 5-3	Pinion	1	34	GB/T9074. 4	Screw M5×25	2	63	CG330B-CE. 3-1	Rubber Cover	1
6	GB/T93	Washer 5	2	35	CG230B. 1-1	Clamp A	1	64	GB/T9074. 13	Bolt M5×25	6
7	GB/T70. 1	Screw M5×25	1	36	CG230B. 1-2	Clamp B	1	65	CG415D-1	Cap, Upper	1
8	GB/T70. 1	Screw M5×12	1	37	GB/T9074. 13	Bolt M6×20	4	66	CG415-1	Bracket	1
9	GB/T29. 2	Bolt M6×8	1	38	CG415-2	Blade	1	67	CG230B-1	Rubber Gasket	1
10	GB/T97. 1	Washer 6	1	39	CG415-1	Wire Clamp Band	2	68	CG415-2	Cap, Lower	1
11	CG230B. 5-1	Gear Case	1	40	CG260. 4	Harness Ass'y	1	69	CG261B. 1-1	Handgrip	1
12	GB/T276	Bearing 619/8	1	41	CG230B. 3	Holder Ass'y	1	70	CG230B. 7	Nylon Cutter Head	1
13	CG230B. 5-2	Gear	1	42	CG230B. 3. 1	Harness Clamp	1	71	CG305F. 8. 1	Case	1
14	CG230B. 5-4	Spline Shaft	1	43	CG230B. 3. 2	Clamp	1	72	CG230B. 7-1	Left Nut	1
15	GB/T276	Bearing 6000-2RS/P5	1	44	GB/T70. 1	Screw M5×20	2	73	CG305F. 8-5	Washer	1
16	GB/T893. 2	Circlip for Hole 26	1	45	CG261B. 2. 1	Lever Ass'y	1	74	CG305F. 8-3	Spring	1
17	CG230B. 5-5	Holder A	1	46	GB/T846	Screw ST2. 9×13	1	75		Cord	2
18	CG230B. 5-6	Holder B	1	47	BL750. 3-9	Button	1	76	CG305F. 8-1	Cord Holder	1
19	CG230B. 6. 1	Left Nut	1	48	BL750. 3-7	Spring	1	77	CG305F. 8-7	Platen	1
20	GB/T97. 1	Washer 5	1	49	BL750. 3-8	Clock Pin	1	78	CG305F. 8-2	Cover	1
21	CG230B. 2	Pipe Comp.	1	50	BL750. 3-4	Handgrip	1	79	GB/T9074. 4	Screw M5×12	1
22	CG230B. 2-2	Rubber Cover	6	51	BL750. 3-1	Spring	1	80	GB/T848	Washer 6	1
23	CG230B. 2-3	Oil-Bearing	6	52	BL750. 3-6	Box, Right	1	81	GB/T9074. 4	Screw M5×20	4
24	CG230B. 2-1	Drive Shaft	1	53	GB/T845	Screw ST2. 9×18	2	82	CG230B. 4. 1	Holder Ass'y	1
25	CG230B. 2-4	Drive Shaft Pipe	1	54	GB/T70. 1	Screw M5×30	1	83	CG330B-CE. 1-1	Safety Guard	1
26	CG230B. 1	Clutch Comp.	1	55	CG430. 1. 1. 1	Cable Comp.	1	84	CG330B-CE. 1. 2	Backing Board Comp.	2
27	CG230B. 1. 1	Clutch Drum Comp.	1	56	CG261B. 2. 1-1	Tube	1	85	CG330B-CE. 2. 1	Cover Comp.	1
28	GB/T893. 1	Circlip for Hole 35	1	57	CG261B. 2. 1. 1	Stop Button Comp.	1	86	CG330B-CE. 2. 1-1	Safety Guard	1
29	GB/T276	Bearing 6202-2RS/P6	1	58	BL750. 3-3	Handgrip	1	87	CG330B-CE. 2. 1-2	Blade	1